

Koyo®

BALL & ROLLER BEARINGS

POPULAR SIZE



ISO 9001/QS-9000
Certificate No. 927265



KOYO SEIKO CO., LTD.

CAT.NO.203E-1

Copyright KOYO 1997

The contents of this catalogue are the copyright of KOYO and may not be reproduced unless permission is granted.

Cares have been taken in every aspect to ensure the correctness of the data contained in this catalogue but no liability can be accepted for any mistakes or omissions.

- **Technical section**

1. Structures and types
2. Internal clearance
3. Bearing numbers
4. Handling of bearings

- **Bearing specification tables**

Deep groove ball bearings d 3 – 200 mm

Angular contact ball bearings d 10 – 200 mm

Self-aligning ball bearings d 10 – 100 mm

Cylindrical roller bearings d 20 – 200 mm

Tapered roller bearings d 15 – 200 mm

Spherical roller bearings d 25 – 300 mm

Thrust ball bearings d 10 – 200 mm

Spherical thrust roller bearings d 60 – 300 mm

Ball bearing units d 10 – 140 mm

Locknuts and lockwashers

- **Supplementary tables**
- **Products information**



BALL & ROLLER BEARINGS

POPULAR SIZE

CAT. NO. 203E-1

● **VALUE & TECHNOLOGY**



• Standard ball and roller bearings



• Ball bearing units



• Locknuts



• Lockwashers

Introduction

This catalogue is prepared to show most popular ball and roller bearings used in various applications. These bearings are generally available from stock.

As the technical information mentioned in this catalogue is limited, when more detailed information is required for new design of application, it is recommended that the KOYO General Catalogue is referred.

For trouble free operation of the application, it is recommended to keep the bearings in proper condition avoiding from extreme high or low temperature, wet, contamination, hitting, dropping, etc.. Also proper handling and maintenance are required at mounting, regular inspection, overhaul, and dismounting by the use of suitable tools, jigs and lubricant.

*For improvements, as well as other reasons, the contents of this catalogue are subject to change without prior notice.

Contents

Technical section

1. Rolling bearing structures and types	A 1
2. Bearing internal clearance	A 11
3. Bearing numbers	A 21
4. Handling of bearings	A 22

Bearing specification tables

Deep groove ball bearings	<i>d</i> 3 – 200 mm	B 2
Angular contact ball bearings	<i>d</i> 10 – 200 mm	B 16
Self-aligning ball bearings	<i>d</i> 10 – 100 mm	B 34
Cylindrical roller bearings	<i>d</i> 20 – 200 mm	B 42
Tapered roller bearings	<i>d</i> 15 – 200 mm	B 50
Spherical roller bearings	<i>d</i> 25 – 300 mm	B 70
Thrust ball bearings	<i>d</i> 10 – 200 mm	B 88
Spherical thrust roller bearings	<i>d</i> 60 – 300 mm	B 94
Ball bearing units	<i>d</i> 10 – 140 mm	B 98
Locknuts and lockwashers		B 132

Supplementary tables (Contents)	C 1
---------------------------------------	-----

Products information (Contents)	D 1
---------------------------------------	-----

1. Rolling bearing structures and types

1-1 Structure

Rolling bearings (bearings hereinafter) normally comprise bearing rings, rolling elements and a cage (see Fig. 1-1).

Rolling elements are arranged between inner and outer rings with a cage, which retains the rolling elements in correct relative position, so they do not touch one another. With this structure, a smooth rolling motion is realized during operation.

Bearings are classified as follows, by the number of rows of rolling elements: single-row, double-row, or multi-row (triple- or four-row) bearings.

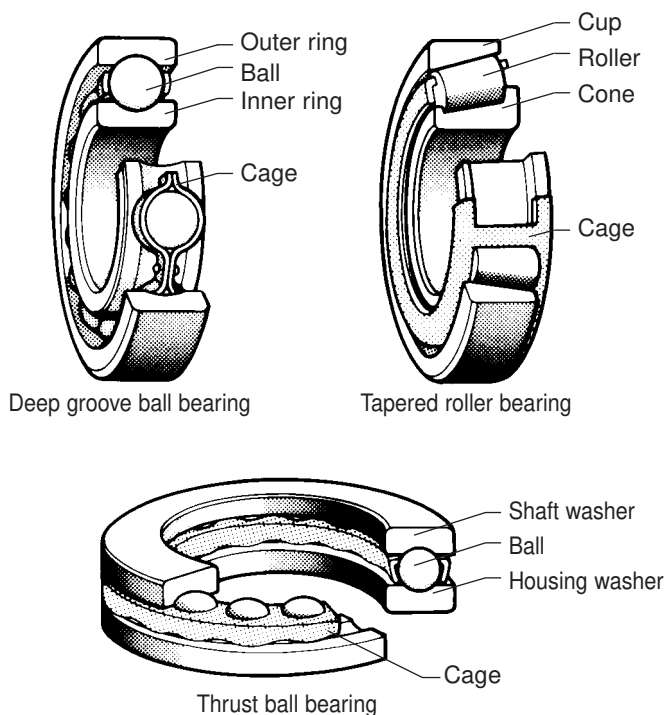

Note) In thrust bearings inner and outer rings and also called "shaft washer" and "housing washer" respectively; in tapered roller bearings, the respective forms are "cone" and "cup."

Fig. 1-1 Bearing structure

1) Bearing rings

The path of the rolling elements is called the raceway; and, the section of the bearing rings where the elements roll is called the raceway surface. In the case of ball bearings, since grooves are provided for the balls, they are also referred to as raceway grooves.

The inner ring is normally engaged with a shaft; and, the outer ring with a housing.

2) Rolling element

Rolling elements may be either balls or rollers. Many types of bearings with various shapes of rollers are available.

- Ball
- Cylindrical roller ($L_w \leq 3D_w$)¹⁾
- Long cylindrical roller ($3D_w < L_w < 10D_w, D_w > 5 \text{ mm}$)¹⁾
- Needle roller ($3D_w < L_w < 10D_w, D_w \leq 5 \text{ mm}$)¹⁾
- Tapered roller (tapered trapezoid)
- Convex roller (barrel shape)

Note 1) $\left\{ \begin{array}{ll} L_w : \text{roller length} & (\text{mm}) \\ D_w : \text{roller diameter} & (\text{mm}) \end{array} \right.$

3) Cage

The cage guides the rolling elements along the bearing rings, retaining the rolling elements in correct relative position. There are various types of cages including pressed, machined, molded, and pin type cages.

Due to lower friction resistance than that found in full complement roller and ball bearings, bearings with a cage are more suitable for use under high speed rotation.

1-2 Type

The contact angle (α) is the angle formed by the direction of the load applied to the bearing rings and rolling elements, and a plan perpendicular to the shaft center, when the bearing is loaded.

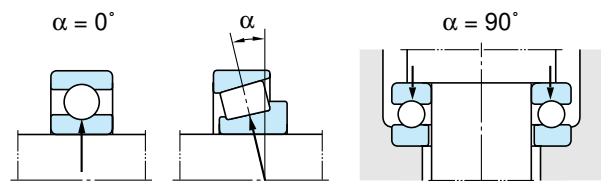

Bearings are classified into two types in accordance with the contact angle (α).

- Radial bearings ($0^\circ \leq \alpha \leq 45^\circ$)
... designed to accommodate mainly radial load.
- Thrust bearings ($45^\circ < \alpha \leq 90^\circ$)
... designed to accommodate mainly axial load.

Rolling bearings are classified in Fig. 1-2, and characteristics of each bearing type are described in Tables 1-1 to 1-8.

1. Rolling bearing structures and types

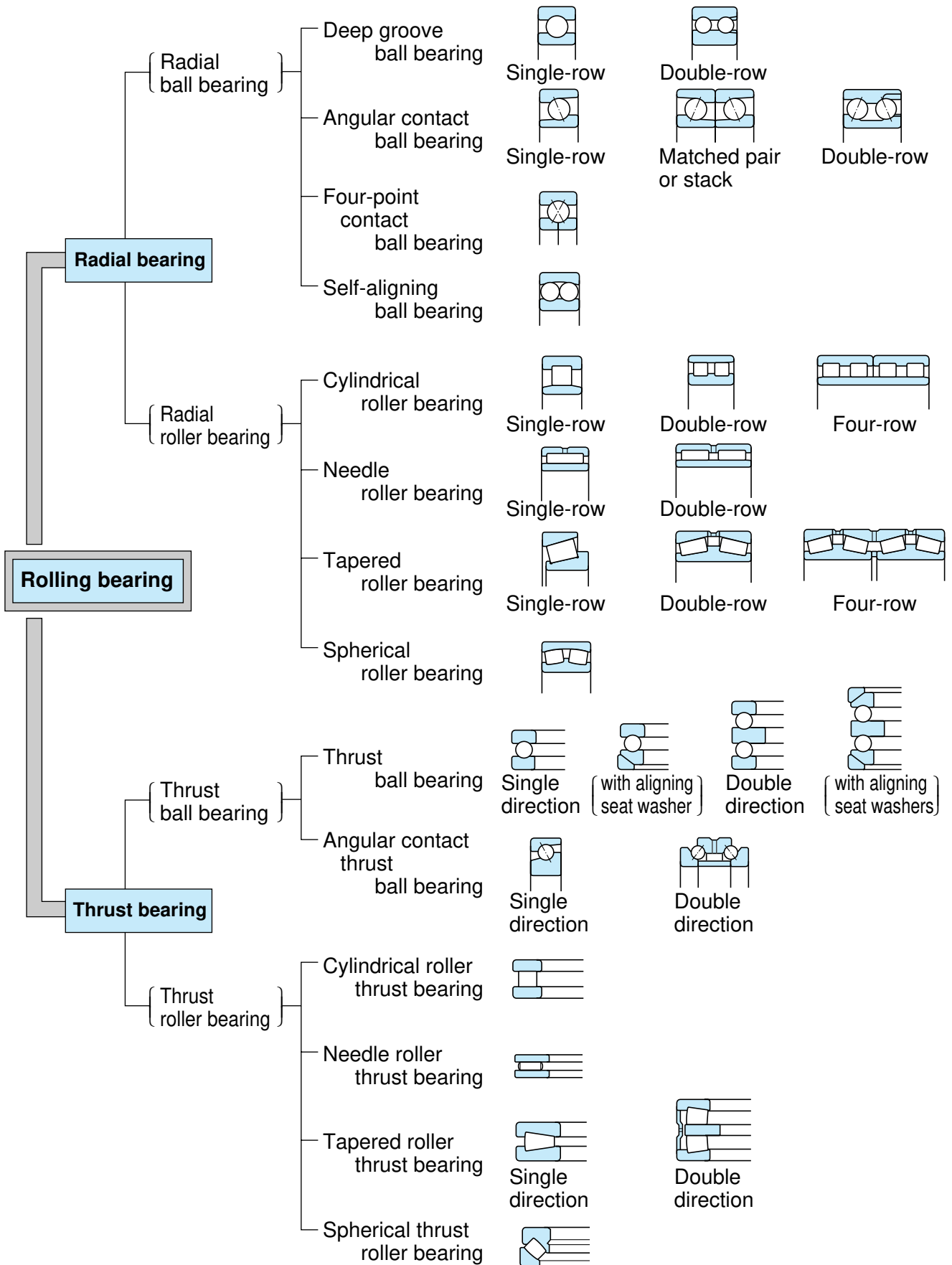
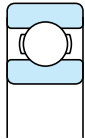
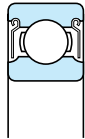
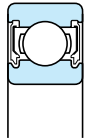
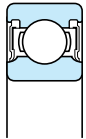
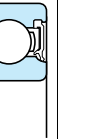

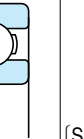
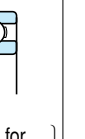
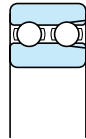

Fig. 1-2 Rolling bearings

Table 1-1 Deep groove ball bearings

Single-row								Double-row
Open type	Shielded type	Non-contact sealed type	Contact sealed type	Extremely light contact sealed type	With locating snap ring	Flanged type	Maximum type	
								
	ZZ	2RU	2RS 2RK	2RD	NR] Suitable for extra-small or miniature bearing		
680, 690, 6800, 6900, 16000		600, 620, 630, (ML), (OB) ...	Extra-small, miniature bearing				M6200 M6300	4200 4300

- The most popular types among rolling bearings, widely used in a variety of industries.
- Radial load and axial load in both directions can be accommodated.
- Suitable for operation at high speed, with low noise and low vibration.
- Sealed bearings employing steel shields or rubber seals are filled with the appropriate volume of grease when manufactured.

- Bearings with a flange or locating snap ring attached on the outer ring are easily mounted in housings for simple positioning of housing location.
- In spite of having the same boundary dimensions as standard bearings, maximum type bearings have a higher load rating because a filling slot on each of the inner and outer rings, allows a greater number of balls to be inserted than do standard bearings.

[Recommended cages] Pressed steel cage (ribbon types, snap type ...single-row, S type ...double-row), copper alloy or phenolic resin machined cage, synthetic resin molded cage

[Main applications]
 Automobile : front and rear wheels, transmissions, electric devices
 Electric equipment : standard motors, electric appliances for domestic use
 Others : measuring instruments, internal combustion engines, construction equipment, railway rolling stock, cargo transport equipment, agricultural equipment, equipment for other industrial uses

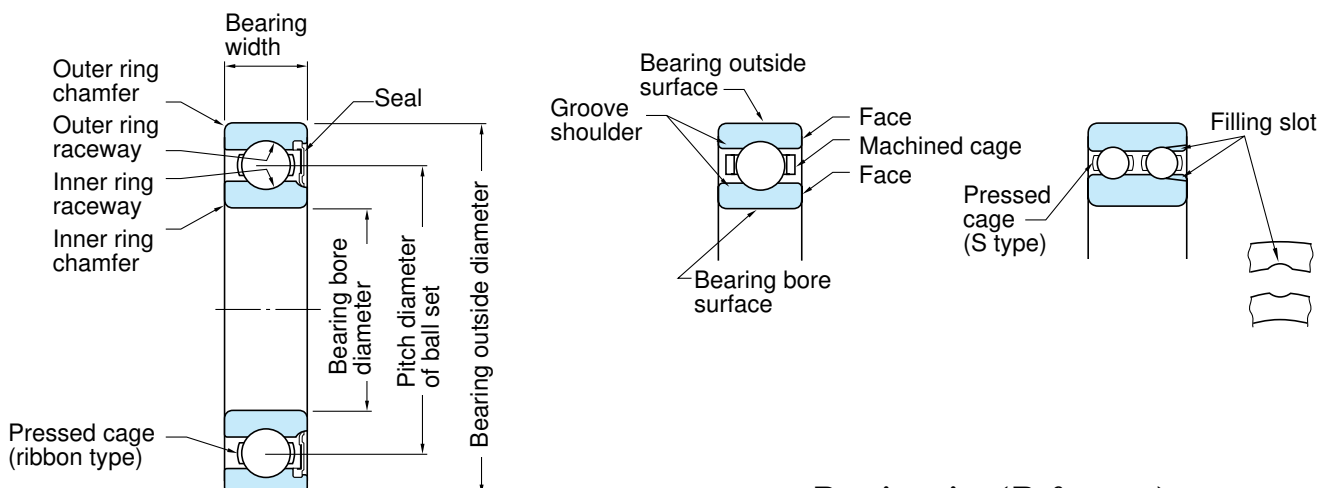

Bearing size (Reference) Unit mm

Connotation	Bore diameter	Outside diameter
Miniature	–	Under 9
Extra-small	Under 10	9 or more
Small size	10 or more	80 or less
Medium size	–	80 – 180
Large size	–	180 – 800
Extra-large size	–	Over 800

1. Rolling bearing structures and types

Table 1-2 Angular contact ball bearings

Single-row			Matched pair			Double-row	
For high-speed use			Back-to-back arrangement	Face-to-Face arrangement	Tandem arrangement		
		ACH					
(With pressed cage)	(With machined cage)		DB	DF	DT	(With filling slot)	
7000 , 7200 , 7300 , 7400 Contact angle 30°						3200	5200
7000B, 7200B, 7300B, 7400B Contact angle 40°						3300	5300
7900C, 7000C, 7200C, 7300C } Contact angle 15°						Contact angle 32°	Contact angle 24°
ACH900C, ACH000C							
<ul style="list-style-type: none"> ■ Bearing rings and balls possess their own contact angle which is normally 15°, 30° or 40°. <ul style="list-style-type: none"> ┌ Larger contact angle ... higher resistance against axial load └ Smaller contact angle ... more advantageous for high-speed rotation ■ Single-row bearings can accommodate radial load and axial load in one direction. ■ DB and DF matched pair bearings and double-row bearings can accommodate radial load and axial load in both directions. ■ DT matched pair bearings are used for applications where axial load in one direction is too large for one bearing to accept. ■ ACH type high speed bearings were designed to contain more balls than standard bearings by minimizing the ball diameter, to offer improved performance in machine tools. ■ Angular contact ball bearings are used for high accuracy and high-speed operation. 						<ul style="list-style-type: none"> ■ Axial load in both directions and radial load can be accommodated by adapting a structure pairing two single-row angular contact ball bearings back to back. ■ For bearings with no filling slot, the sealed type is available. 	
						ZZ (Shielded)	2RS (Sealed)

[Recommended cages] Pressed steel cage (conical type ...single-row : S type, snap type ...double-row), copper alloy or phenolic resin machined cage, synthetic resin molded cage

[Main applications] Single-row : machine tool spindles, high frequency motors, gas turbines, centrifugal separators, front wheels of small size automobiles, differential pinion shafts
 Double-row : hydraulic pumps, roots blowers, air-compressors, transmissions, fuel injection pumps, printing equipment

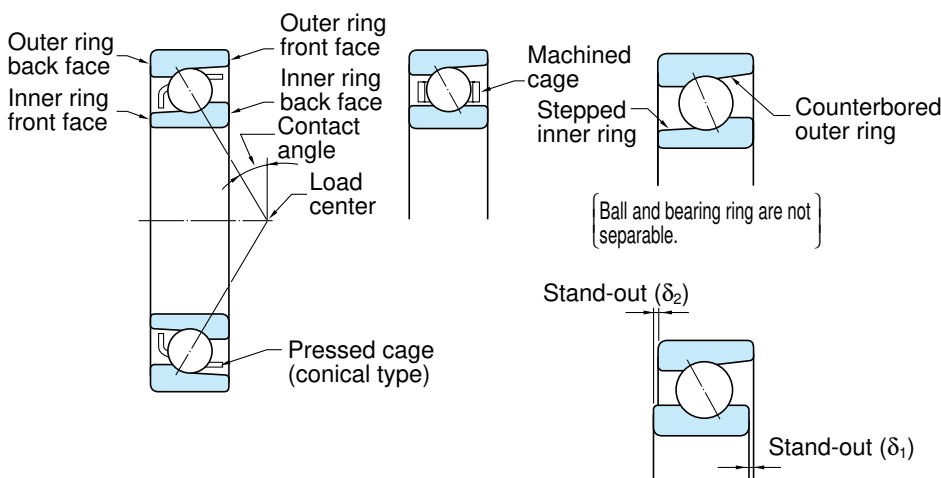

Contact angles of Koyo bearings (Reference)

Contact angle	Supplementary code
15°	C
20°	CA
25°	AC
30°	A (Omitted)
35°	E
40°	B

"G type" bearings are processed (with flush ground) such that the stand-out turns out to be $\delta_1 = \delta_2$. The matched pair DB, DF, and DT, or stack are available.

Table 1-3 Self-aligning ball bearings

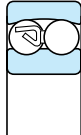
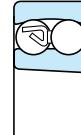
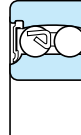
Cylindrical bore	Tapered bore	Sealed
	 K (Taper 1 : 12)	 2RS
120, 130 1200,1300 2200,2300	{ 11200,11300 ... extended inner ring type }	2200 2RS 2300 2RS

- Spherical outer ring raceway allows self-alignment, accommodating shaft or housing deflection and misaligned mounting conditions.
- Tapered bore design can be mounted readily using an adapter.

[Recommended cages]

Pressed steel cage { staggered type 12, 13,
22...2RS, 23...2RS
snap type 22, 23 }

[Main applications]

Power transmission shaft of wood working and spinning machines, plummer blocks

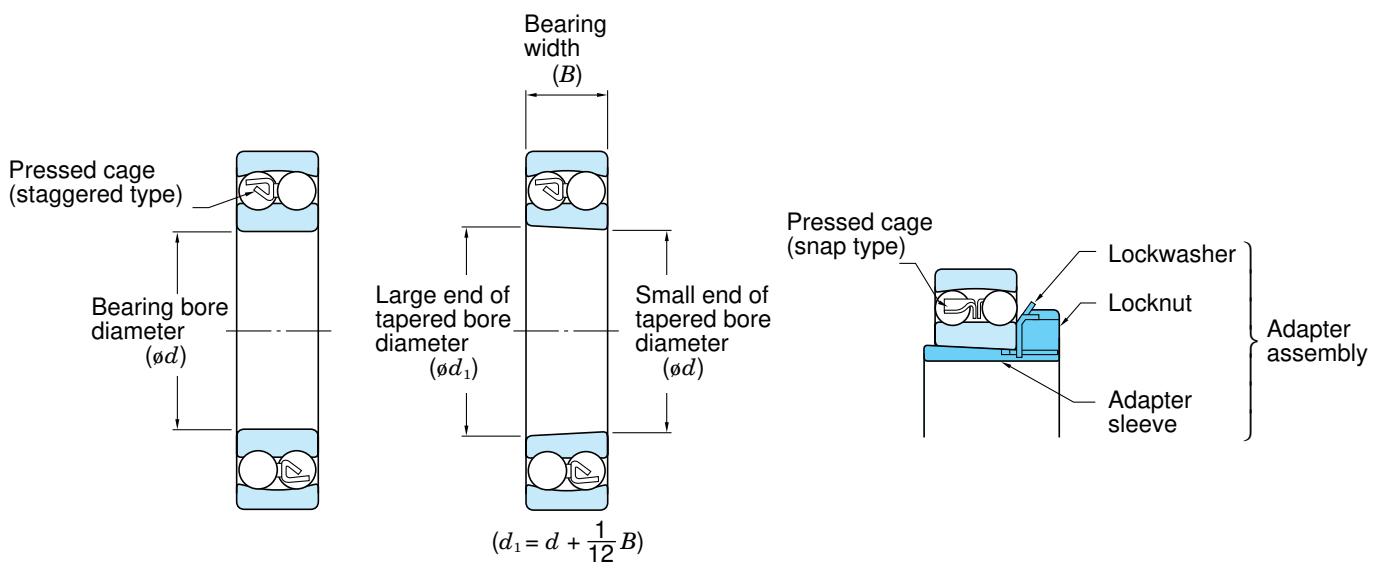

1. Rolling bearing structures and types

Table 1-4 Cylindrical roller bearings

Single-row						Double-row		Four-row
NU	NJ	NUP	N	NF	NH	NNU	NN	(Mainly use on rolling mill roll neck)
NU1000, NU200(R), NU300(R), NU400 NU2200(R), NU2300(R) NU3200, NU3300						Cylindrical bore NNU4900 NN3000	Tapered bore NNU4900K NN3000K	(FC), (4CR)

- Since the design allowing linear contact of cylindrical rollers with the raceway provides strong resistance to radial load, this type is suitable for use under heavy radial load and impact load, as well as at high speed.
- N and NU types are ideal for use on the free side : they are movable in the shaft direction in response to changes in bearing position relative to the shaft or housing, which are caused by heat expansion of the shaft or improper mounting.

- NJ and NF types can accommodate axial load in one direction ; and NH and NUP types can accommodate partial axial load in both directions.
- With separable inner and outer ring, this type ensures easy mounting.
- Due to their high rigidity, NNU and NN types are widely used in machine tool spindles.

[Recommended cages] Pressed steel cage (Z type), copper alloy machined cage, pin type cage, synthetic resin molded cage

[Main applications] Large and medium size motors, traction motors, generators, internal combustion engines, gas turbines, machine tool spindles, speed reducers, cargo transport equipment, and other industrial equipment

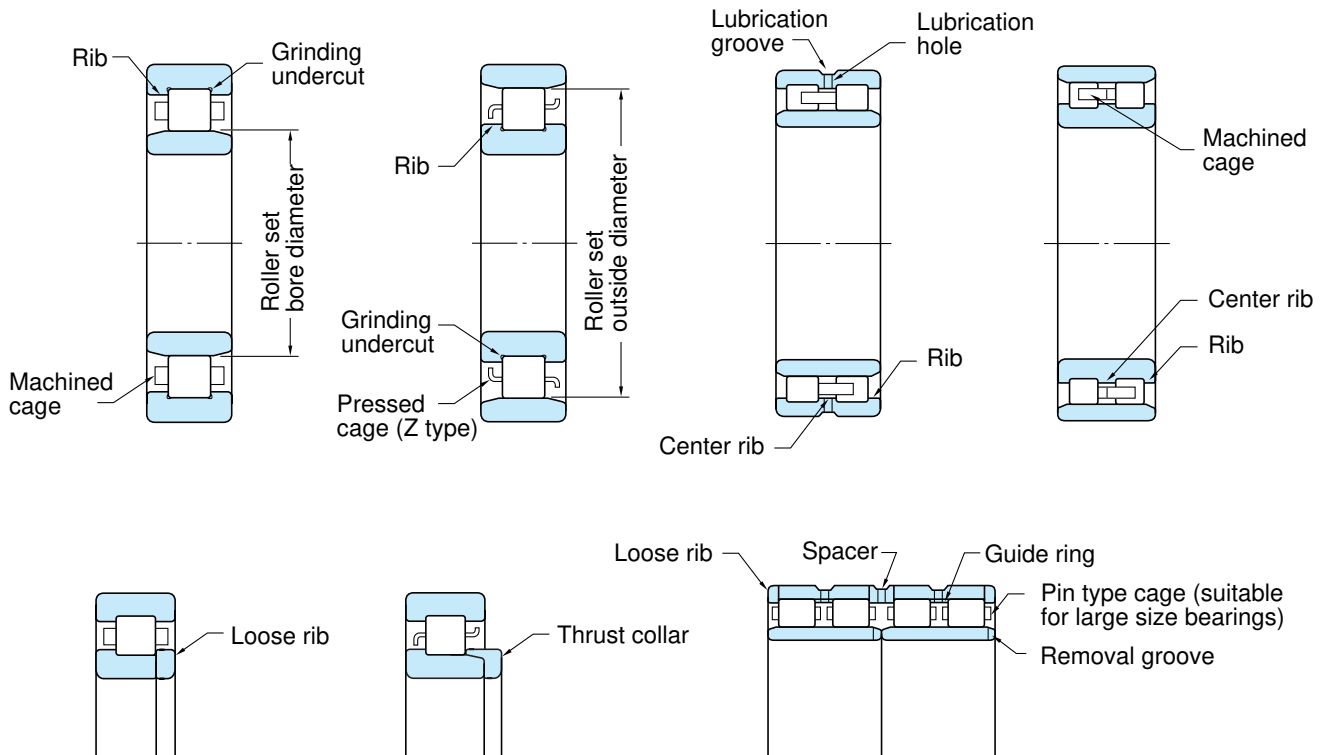

Table 1-5 Tapered roller bearings

Single-row				Double-row		Four-row
		Flanged type		TDO type	TDI type	(Mainly used on rolling mill roll neck)
[Standard contact angle]		[Intermediate contact angle]		46200	45200	37200
32900JR		30200JR		46200A	45300	47200
32000JR		32200JR		46300	(45T)	47300
33000JR		33200JR		46300A		(47T)
33100JR		30300JR		(46T)		
32300JR		32300CR				
		30300DJ				
		30300DJR				
		31300JR				

- Tapered rollers assembled in the bearings are guided by the cone back face rib.
- The raceway surfaces of cone and cup and the rolling contact surface of rollers are designed so that the respective apexes converge at a point on the bearing center line.
- Single-row bearings can accommodate radial load and axial load in one direction, and double-row bearings can accommodate radial load and axial load in both directions.
- This type of bearing is suitable for use under heavy load or impact load.

- Bearings are classified into standard, intermediate and steep types, in accordance with their contact angle (α).
The larger the contact angle is, the greater the bearing resistance to axial load.
- Since cup and cone assembly can be separated from each other, mounting is easy.
- Bearings designated by the suffix " J " and " JR " are interchangeable internationally.
- Items sized in inches are still widely used.

[Recommended cages] Pressed steel cage, synthetic resin molded cage, pin type cage

[Main applications] Automobile : front and rear wheels, transmissions, differential pinion

Others : machine tool spindles, construction equipment, large size agricultural equipment, railway rolling stock speed reduction gears, rolling mill roll necks and speed reducers, etc

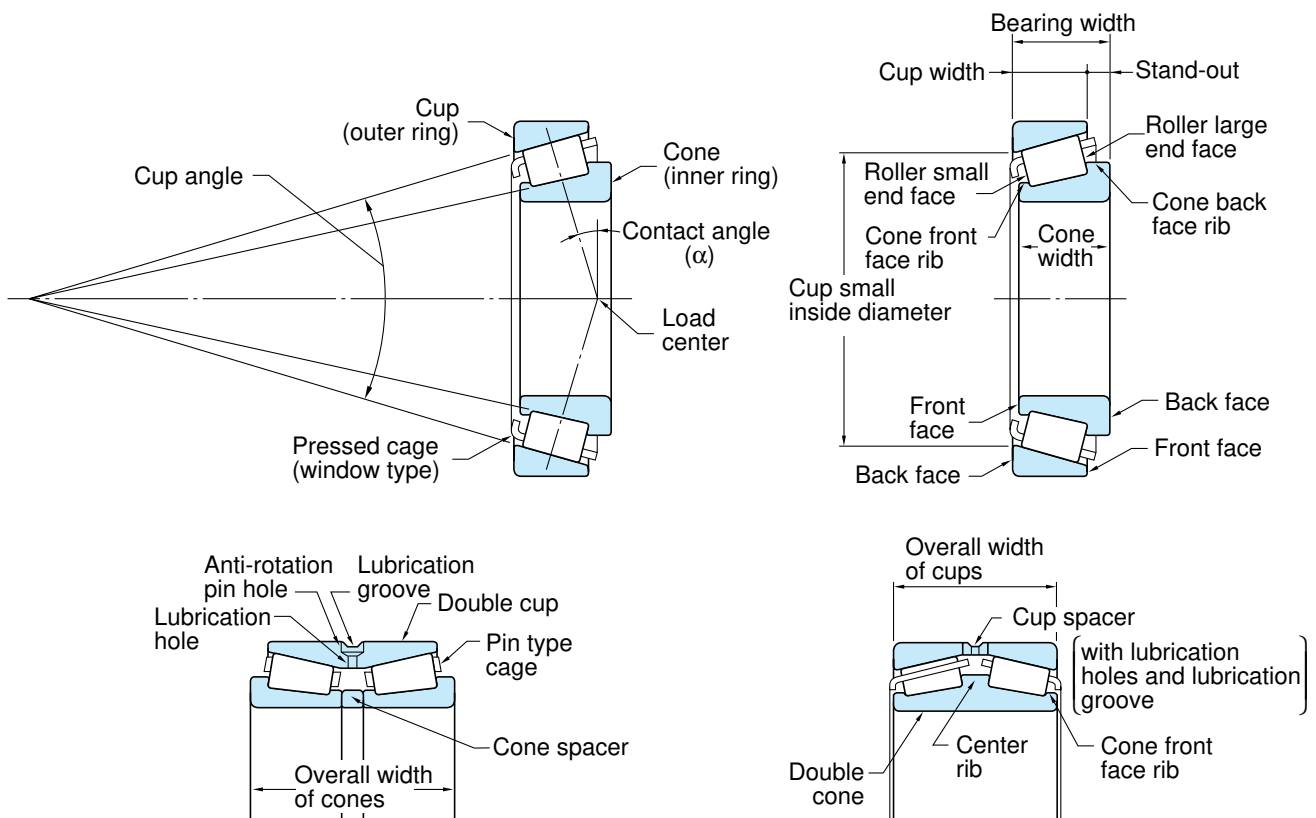

1. Rolling bearing structures and types

Table 1-6 Spherical roller bearings

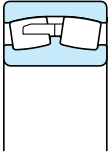
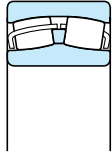
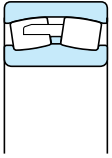
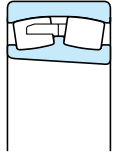
Cylindrical bore		Tapered bore
Convex asymmetrical roller type	Convex symmetrical roller type	
		
R, RR	RH, RHR	RHA
		
		K or K30

23900R, 23000R (RH, RHA), 23100R (RH, RHA), 22200R (RH, RHA), 21300R (RH)
24000R (RH, RHA), 24100R (RH, RHA), 23200R (RH, RHA), 22300R (RH, RHA)

- Spherical roller bearings comprising barrel-shaped convex rollers, double-row inner ring and outer ring are classified into three types : R (RR), RH (RHR) and RHA, according to their internal structure.
- With the bearing designed such that the circular arc center of the outer ring raceway matches with the bearing center, the bearing is self-aligning, insensitive to errors of alignment of the shaft relative to the housing, and to shaft bending.
- This type can accommodate radial load and axial load in both directions, which makes it especially suitable for applications in which heavy load or impact load is applied.

- The tapered bore type can be easily mounted / dismounted by using an adapter or withdrawal sleeve.

There are two types of tapered bores (tapered ratio) :

- 1 : 30 { supplementary code K30 } ...Suitable for series 240 and 241.
- 1 : 12 { supplementary code K } ...Suitable for series other than 240 and 241.

- Lubrication holes, a lubrication groove and anti-rotation pin hole can be provided on the outer ring. Lubrication holes and a lubrication groove can be provided on the inner ring, too.

[Recommended cages] Copper alloy machined cage, pressed steel cage, pin type cage, synthetic resin molded cage

[Main applications] Paper manufacturing equipment, speed reducers, railway rolling stock axle journals, rolling mill pinion stands, table rollers, crushers, shaker screens, printing equipment, wood working equipment, speed reducers for various industrial uses, plummer blocks

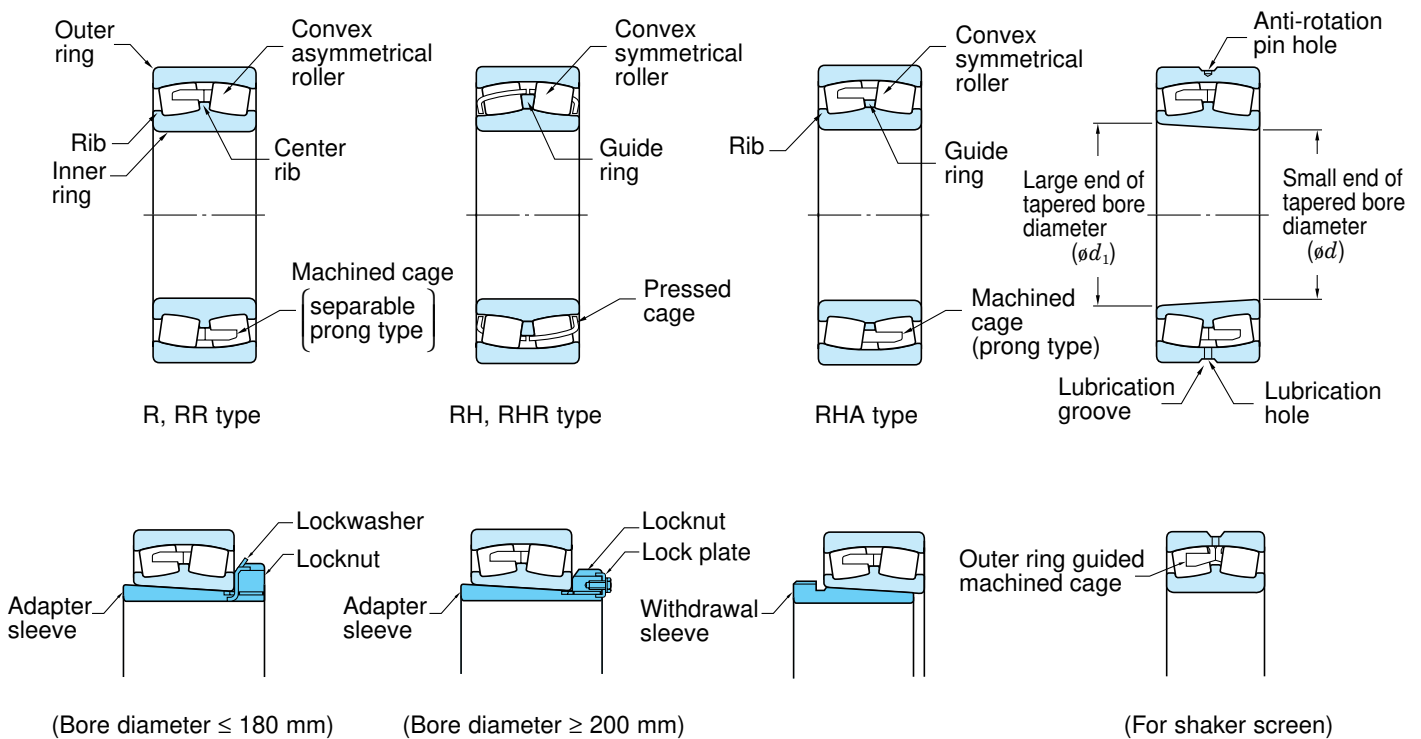

Table 1-7 Thrust ball bearings

Single direction			Double direction		
With flat back faces	With spherical back face	With aligning seat washer	With flat back faces	With spherical back faces	With aligning seat washers
51100 51200 51300 51400	— 53200 53300 53400	— 53200U 53300U 53400U	— 52200 52300 52400	— 54200 54300 54400	— 54200U 54300U 54400U

- This type of bearing comprises washer-shaped rings with raceway groove and ball and cage assembly.
- Washers to be mounted on shafts are called shaft washers (or inner rings); and, washers to be mounted into housings are housing washers (or outer rings).
Central washers of double direction bearings are mounted on the shafts.
- Single direction bearings accommodate axial load in one direction, and double direction bearings accommodate axial load in both directions. (Both of these bearings cannot accommodate radial loads.)
- Since bearings with a spherical back face are self-aligning, it helps to compensate for mounting errors.

[Recommended cages] Pressed steel cage, copper alloy or phenolic resin machined cage, synthetic resin molded cage

[Main applications] Automobile king pins, machine tool spindles

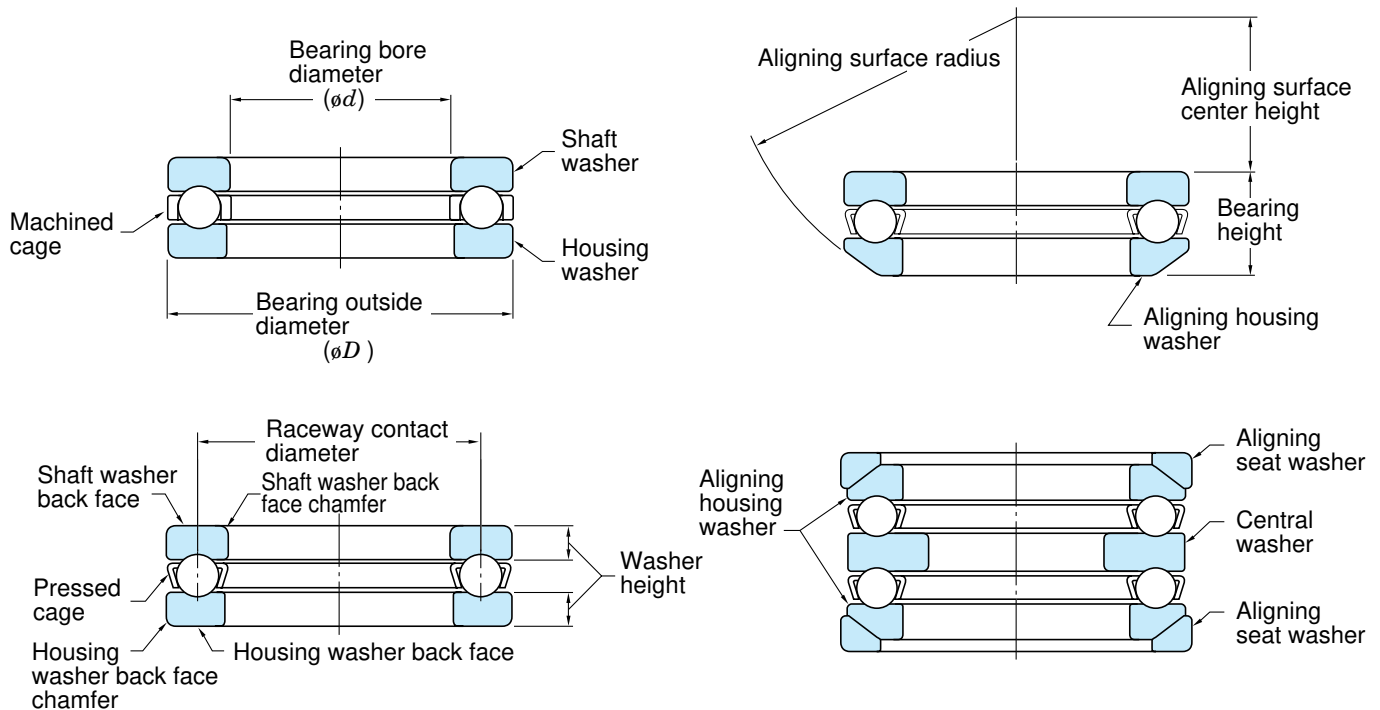
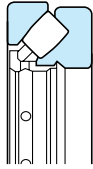

Table 1-8 Spherical thrust roller bearings



29200
29300
29400

- This type of bearing, comprising barrel-shaped convex rollers arranged at an angle with the axis, is self-aligning due to spherical housing washer raceway; therefore, shaft inclination can be compensated for to a certain degree.
- Great axial load resistance is provided.
This type can accommodate a small amount of radial load as well as heavy axial load.
- Normally, oil lubrication is employed.

[Recommended cage]
Copper alloy machined cage

[Main applications]
Hydroelectric generators, vertical motors, propeller shafts for ships, screw down speed reducers, jib cranes, coal mills, pushing machines, molding machines

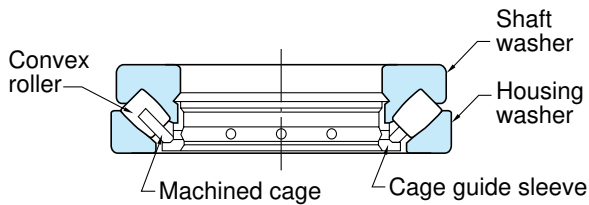

2. Bearing internal clearance

Table 2-1 Radial internal clearance of deep groove ball bearings (cylindrical bore)

Unit μm

Nominal bore diameter <i>d</i> , mm		Clearance									
		C2		CN		C3		C4		C5	
over	up to	min.	max.	min.	max.	min.	max.	min.	max.	min.	max.
2.5	6	0	7	2	13	8	23	14	29	20	37
6	10	0	7	2	13	8	23	14	29	20	37
10	18	0	9	3	18	11	25	18	33	25	45
18	24	0	10	5	20	13	28	20	36	28	48
24	30	1	11	5	20	13	28	23	41	30	53
30	40	1	11	6	20	15	33	28	46	40	64
40	50	1	11	6	23	18	36	30	51	45	73
50	65	1	15	8	28	23	43	38	61	55	90
65	80	1	15	10	30	25	51	46	71	65	105
80	100	1	18	12	36	30	58	53	84	75	120
100	120	2	20	15	41	36	66	61	97	90	140
120	140	2	23	18	48	41	81	71	114	105	160
140	160	2	23	18	53	46	91	81	130	120	180
160	180	2	25	20	61	53	102	91	147	135	200
180	200	2	30	25	71	63	117	107	163	150	230
200	225	2	35	25	85	75	140	125	195	175	265
225	250	2	40	30	95	85	160	145	225	205	300
250	280	2	45	35	105	90	170	155	245	225	340
280	315	2	55	40	115	100	190	175	270	245	370
315	355	3	60	45	125	110	210	195	300	275	410
355	400	3	70	55	145	130	240	225	340	315	460

- Remarks) 1. For measured clearance, the increase of radial internal clearance caused by the measurement load should be added to the values in the above table for correction. Amounts for correction are as shown below.
Of the amounts for clearance correction in the C2 column, the smaller is applied to the minimum clearance, the larger to the maximum clearance.
2. Values typed in *Italics* are based on the Koyo standards.

Nominal bore diameter <i>d</i> , mm		Measurement load	Amounts of clearance correction, μm				
			C2	CN	C3	C4	C5
over	up to	N					
2.5	18	24.5	3 – 4	4	4	4	4
18	50	49	4 – 5	5	6	6	6
50	280	147	6 – 8	8	9	9	9

Table 2-2 Radial internal clearance of extra-small / miniature ball bearings

Unit μm

Clearance code	M1		M2		M3		M4		M5		M6	
	min.	max.	min.	max.	min.	max.	min.	max.	min.	max.	min.	max.
Clearance	0	5	3	8	5	10	8	13	13	20	20	28

Remark) For measured clearance, the following amounts should be added for correction.

Measurement load	Amounts of clearance correction, μm					
	M1	M2	M3	M4	M5	M6
2.3	1	1	1	1	1	1

Extra-small ball bearing : 9 mm or larger in outside diameter and under 10 mm in bore diameter
 Miniature ball bearing : Under 9 mm in outside diameter

2. Bearing internal clearance

**Table 2-3 Axial internal clearance of matched pair angular contact ball bearings
(measurement clearance) ¹⁾**

Unit μm

Nominal bore diameter d , mm		Contact angle : 15°				Contact angle : 30°							
		C2		CN		C2		CN		C3		C4	
over	up to	min.	max.	min.	max.	min.	max.	min.	max.	min.	max.	min.	max.
–	10	13	33	33	53	3	14	10	30	30	50	50	70
10	18	15	35	35	55	3	16	10	30	30	50	50	70
18	24	20	40	45	65	3	20	20	40	40	60	60	80
24	30	20	40	45	65	3	20	20	40	40	60	60	80
30	40	20	40	45	65	3	20	25	45	45	65	70	90
40	50	20	40	50	70	3	20	30	50	50	70	75	95
50	65	30	55	65	90	9	27	35	60	60	85	90	115
65	80	30	55	70	95	10	28	40	65	70	95	110	135
80	100	35	60	85	110	10	30	50	75	80	105	130	155
100	120	40	65	100	125	12	37	65	90	100	125	150	175
120	140	45	75	110	140	15	40	75	105	120	150	180	210
140	160	45	75	125	155	15	40	80	110	130	160	210	240
160	180	50	80	140	170	15	45	95	125	140	170	235	265
180	200	50	80	160	190	20	50	110	140	170	200	275	305

Nominal bore diameter d , mm		Contact angle : 40°							
		C2		CN		C3		C4	
over	up to	min.	max.	min.	max.	min.	max.	min.	max.
–	10	2	10	6	18	16	30	26	40
10	18	2	12	7	21	18	32	28	44
18	24	2	12	12	26	20	40	30	50
24	30	2	14	12	26	20	40	40	60
30	40	2	14	12	26	25	45	45	65
40	50	2	14	12	30	30	50	50	70
50	65	5	17	17	35	35	60	60	85
65	80	6	18	18	40	40	65	70	95
80	100	6	20	20	45	55	80	85	110
100	120	6	25	25	50	60	85	100	125
120	140	7	30	30	60	75	105	125	155
140	160	7	30	35	65	85	115	140	170
160	180	7	31	45	75	100	130	155	185
180	200	7	37	60	90	110	140	170	200

Note 1) Including increase of clearance caused by measurement load.

Table 2-4 Radial internal clearance of double-row angular contact ball bearings

Unit μm

Nominal bore diameter <i>d</i> , mm		Clearance					
		CD 2		CD N		CD 3	
over	up to	min.	max.	min.	max.	min.	max.
2.5	10	0	7	2	10	8	18
10	18	0	7	2	11	9	19
18	24	0	8	2	11	10	21
24	30	0	8	2	13	10	23
30	40	0	9	3	14	11	24
40	50	0	10	4	16	13	27
50	65	0	11	6	20	15	30
65	80	0	12	7	22	18	33
80	100	0	12	8	24	22	38
100	120	0	13	9	25	24	42
120	140	0	15	10	26	25	44
140	160	0	16	11	28	26	46
160	180	0	17	12	30	27	47
180	200	0	18	14	32	28	48

2. Bearing internal clearance

Table 2-5 Radial internal clearance of self-aligning ball bearings

Unit μm

Nominal bore diameter <i>d</i> , mm		Cylindrical bore bearing clearance										Tapered bore bearing clearance									
		C2		CN		C3		C4		C5		C2		CN		C3		C4		C5	
over	up to	min.	max.	min.	max.	min.	max.	min.	max.	min.	max.	min.	max.	min.	max.	min.	max.	min.	max.	min.	max.
2.5	6	1	8	5	15	10	20	15	25	21	33	–	–	–	–	–	–	–	–	–	–
6	10	2	9	6	17	12	25	19	33	27	42	–	–	–	–	–	–	–	–	–	–
10	14	2	10	6	19	13	26	21	35	30	48	–	–	–	–	–	–	–	–	–	–
14	18	3	12	8	21	15	28	23	37	32	50	–	–	–	–	–	–	–	–	–	–
18	24	4	14	10	23	17	30	25	39	34	52	7	17	13	26	20	33	28	42	37	55
24	30	5	16	11	24	19	35	29	46	40	58	9	20	15	28	23	39	33	50	44	62
30	40	6	18	13	29	23	40	34	53	46	66	12	24	19	35	29	46	40	59	52	72
40	50	6	19	14	31	25	44	37	57	50	71	14	27	22	39	33	52	45	65	58	79
50	65	7	21	16	36	30	50	45	69	62	88	18	32	27	47	41	61	56	80	73	99
65	80	8	24	18	40	35	60	54	83	76	108	23	39	35	57	50	75	69	98	91	123
80	100	9	27	22	48	42	70	64	96	89	124	29	47	42	68	62	90	84	116	109	144
100	120	10	31	25	56	50	83	75	114	105	145	35	56	50	81	75	108	100	139	130	170
120	140	10	38	30	68	60	100	90	135	125	175	40	68	60	98	90	130	120	165	155	205
140	160	15	44	35	80	70	120	110	161	150	210	45	74	65	110	100	150	140	191	180	240

Table 2-6 Radial internal clearance of electric motor bearings

1) Deep groove ball bearing

Unit μm

Nominal bore diameter <i>d</i> , mm		Clearance	
		CM	
over	up to	min.	max.
10¹⁾	18	4	11
18	30	5	12
30	50	9	17
50	80	12	22
80	120	18	30
120	160	24	38

Note 1) 10 mm is included.

Remark) To adjust for change of clearance due to measuring load, use correction values shown in Table 2-1.

2) Cylindrical roller bearing

Unit μm

Nominal bore diameter <i>d</i> , mm		Clearance			
		Interchangeability CT		Non-interchangeability CM	
over	up to	min.	max.	min.	max.
24	40	15	35	15	30
40	50	20	40	20	35
50	65	25	45	25	40
65	80	30	50	30	45
80	100	35	60	35	55
100	120	35	65	35	60
120	140	40	70	40	65
140	160	50	85	50	80
160	180	60	95	60	90
180	200	65	105	65	100

[Note] "Interchangeability" means interchangeable only among products (sub-units) of the same manufacturer ; not with others.

2. Bearing internal clearance

Table 2-7 Radial internal clearance of cylindrical roller bearings and machined ring needle roller bearings

(1) Cylindrical bore bearing

Unit μm

Nominal bore diameter <i>d</i> , mm		Clearance									
		C2		CN		C3		C4		C5	
over	up to	min.	max.	min.	max.	min.	max.	min.	max.	min.	max.
–	10	0	25	20	45	35	60	50	75	–	–
10	24	0	25	20	45	35	60	50	75	65	90
24	30	0	25	20	45	35	60	50	75	70	95
30	40	5	30	25	50	45	70	60	85	80	105
40	50	5	35	30	60	50	80	70	100	95	125
50	65	10	40	40	70	60	90	80	110	110	140
65	80	10	45	40	75	65	100	90	125	130	165
80	100	15	50	50	85	75	110	105	140	155	190
100	120	15	55	50	90	85	125	125	165	180	220
120	140	15	60	60	105	100	145	145	190	200	245
140	160	20	70	70	120	115	165	165	215	225	275
160	180	25	75	75	125	120	170	170	220	250	300
180	200	35	90	90	145	140	195	195	250	275	330
200	225	45	105	105	165	160	220	220	280	305	365
225	250	45	110	110	175	170	235	235	300	330	395
250	280	55	125	125	195	190	260	260	330	370	440
280	315	55	130	130	205	200	275	275	350	410	485
315	355	65	145	145	225	225	305	305	385	455	535
355	400	100	190	190	280	280	370	370	460	510	600
400	450	110	210	210	310	310	410	410	510	565	665
450	500	110	220	220	330	330	440	440	550	625	735

(2) Tapered bore bearing

Unit μm

Nominal bore diameter d , mm		Non-interchangeable clearance													
		C9 NA ¹⁾		C1 NA		C2 NA		CN NA		C3 NA		C4 NA		C5 NA	
over	up to	min.	max.	min.	max.	min.	max.	min.	max.	min.	max.	min.	max.	min.	max.
12	14	5	10	—	—	—	—	—	—	—	—	—	—	—	—
14	24	5	10	10	20	20	30	35	45	45	55	55	65	75	85
24	30	5	10	10	25	25	35	40	50	50	60	60	70	80	95
30	40	5	12	12	25	25	40	45	55	55	70	70	80	95	110
40	50	5	15	15	30	30	45	50	65	65	80	80	95	110	125
50	65	5	15	15	35	35	50	55	75	75	90	90	110	130	150
65	80	10	20	20	40	40	60	70	90	90	110	110	130	150	170
80	100	10	25	25	45	45	70	80	105	105	125	125	150	180	205
100	120	10	25	25	50	50	80	95	120	120	145	145	170	205	230
120	140	15	30	30	60	60	90	105	135	135	160	160	190	230	260
140	160	15	35	35	65	65	100	115	150	150	180	180	215	260	295
160	180	15	35	35	75	75	110	125	165	165	200	200	240	285	320
180	200	20	40	40	80	80	120	140	180	180	220	220	260	315	355
200	225	20	45	45	90	90	135	155	200	200	240	240	285	350	395
225	250	25	50	50	100	100	150	170	215	215	265	265	315	380	430
250	280	25	55	55	110	110	165	185	240	240	295	295	350	420	475
280	315	30	60	60	120	120	180	205	265	265	325	325	385	470	530
315	355	30	65	65	135	135	200	225	295	295	360	360	430	520	585
355	400	35	75	75	150	150	225	255	330	330	405	405	480	585	660
400	450	45	85	85	170	170	255	285	370	370	455	455	540	650	735
450	500	50	95	95	190	190	285	315	410	410	505	505	600	720	815

Note 1) Clearance C9NA is applied to tapered bore cylindrical roller bearings of JIS tolerance classes 5 and 4.

2. Bearing internal clearance

Table 2-8 Radial internal clearance of spherical roller bearings

(1) Cylindrical bore bearing

Unit μm

Nominal bore diameter <i>d</i> , mm		Clearance									
		C2		CN		C3		C4		C5	
over	up to	min.	max.	min.	max.	min.	max.	min.	max.	min.	max.
14	18	10	20	20	35	35	45	45	60	60	75
18	24	10	20	20	35	35	45	45	60	60	75
24	30	15	25	25	40	40	55	55	75	75	95
30	40	15	30	30	45	45	60	60	80	80	100
40	50	20	35	35	55	55	75	75	100	100	125
50	65	20	40	40	65	65	90	90	120	120	150
65	80	30	50	50	80	80	110	110	145	145	180
80	100	35	60	60	100	100	135	135	180	180	225
100	120	40	75	75	120	120	160	160	210	210	260
120	140	50	95	95	145	145	190	190	240	240	300
140	160	60	110	110	170	170	220	220	280	280	350
160	180	65	120	120	180	180	240	240	310	310	390
180	200	70	130	130	200	200	260	260	340	340	430
200	225	80	140	140	220	220	290	290	380	380	470
225	250	90	150	150	240	240	320	320	420	420	520
250	280	100	170	170	260	260	350	350	460	460	570
280	315	110	190	190	280	280	370	370	500	500	630
315	355	120	200	200	310	310	410	410	550	550	690
355	400	130	220	220	340	340	450	450	600	600	750
400	450	140	240	240	370	370	500	500	660	660	820
450	500	140	260	260	410	410	550	550	720	720	900
500	560	150	280	280	440	440	600	600	780	780	1 000
560	630	170	310	310	480	480	650	650	850	850	1 100
630	710	190	350	350	530	530	700	700	920	920	1 190
710	800	210	390	390	580	580	770	770	1 010	1 010	1 300
800	900	230	430	430	650	650	860	860	1 120	1 120	1 440
900	1 000	260	480	480	710	710	930	930	1 220	1 220	1 570

(2) Tapered bore bearing

Unit μm

Nominal bore diameter <i>d</i> , mm		Clearance									
		C2		CN		C3		C4		C5	
over	up to	min.	max.	min.	max.	min.	max.	min.	max.	min.	max.
18	24	15	25	25	35	35	45	45	60	60	75
24	30	20	30	30	40	40	55	55	75	75	95
30	40	25	35	35	50	50	65	65	85	85	105
40	50	30	45	45	60	60	80	80	100	100	130
50	65	40	55	55	75	75	95	95	120	120	160
65	80	50	70	70	95	95	120	120	150	150	200
80	100	55	80	80	110	110	140	140	180	180	230
100	120	65	100	100	135	135	170	170	220	220	280
120	140	80	120	120	160	160	200	200	260	260	330
140	160	90	130	130	180	180	230	230	300	300	380
160	180	100	140	140	200	200	260	260	340	340	430
180	200	110	160	160	220	220	290	290	370	370	470
200	225	120	180	180	250	250	320	320	410	410	520
225	250	140	200	200	270	270	350	350	450	450	570
250	280	150	220	220	300	300	390	390	490	490	620
280	315	170	240	240	330	330	430	430	540	540	680
315	355	190	270	270	360	360	470	470	590	590	740
355	400	210	300	300	400	400	520	520	650	650	820
400	450	230	330	330	440	440	570	570	720	720	910
450	500	260	370	370	490	490	630	630	790	790	1 000
500	560	290	410	410	540	540	680	680	870	870	1 100
560	630	320	460	460	600	600	760	760	980	980	1 230
630	710	350	510	510	670	670	850	850	1 090	1 090	1 360
710	800	390	570	570	750	750	960	960	1 220	1 220	1 500
800	900	440	640	640	840	840	1 070	1 070	1 370	1 370	1 690
900	1 000	490	710	710	930	930	1 190	1 190	1 520	1 520	1 860

2. Bearing internal clearance

Table 2-9 Radial internal clearance of double / four-row and matched pair tapered roller bearings (cylindrical bore)

Unit μm

Nominal bore diameter <i>d</i> , mm		Clearance									
		C1		C2		CN		C3		C4	
over	up to	min.	max.	min.	max.	min.	max.	min.	max.	min.	max.
14	18	0	10	10	20	20	30	30	40	40	50
18	24	0	10	10	20	20	30	30	40	40	55
24	30	0	10	10	20	20	30	30	45	45	60
30	40	0	12	12	25	25	40	40	55	55	75
40	50	0	15	15	30	30	45	45	60	60	80
50	65	0	15	15	30	30	50	50	70	70	90
65	80	0	20	20	40	40	60	60	80	80	110
80	100	0	20	20	45	45	70	70	100	100	130
100	120	0	25	25	50	50	80	80	110	110	150
120	140	0	30	30	60	60	90	90	120	120	170
140	160	0	30	30	65	65	100	100	140	140	190
160	180	0	35	35	70	70	110	110	150	150	210
180	200	0	40	40	80	80	120	120	170	170	230
200	225	0	40	40	90	90	140	140	190	190	260
225	250	0	50	50	100	100	150	150	210	210	290
250	280	0	50	50	110	110	170	170	230	230	320
280	315	0	60	60	120	120	180	180	250	250	350
315	355	0	70	70	140	140	210	210	280	280	390
355	400	0	70	70	150	150	230	230	310	310	440
400	450	0	80	80	170	170	260	260	350	350	490
450	500	0	90	90	190	190	290	290	390	390	540
500	560	0	100	100	210	210	320	320	430	430	590
560	630	0	110	110	230	230	350	350	480	480	660
630	710	0	130	130	260	260	400	400	540	540	740
710	800	0	140	140	290	290	450	450	610	610	830
800	900	0	160	160	330	330	500	500	670	670	920

3. Bearing numbers

A bearing number is composed of a basic number and a supplementary code, denoting bearing specifications including bearing type, boundary dimensions, running accuracy, and

internal clearance.

The figure below shows the general designation system for metric ball and roller bearings in diagram.

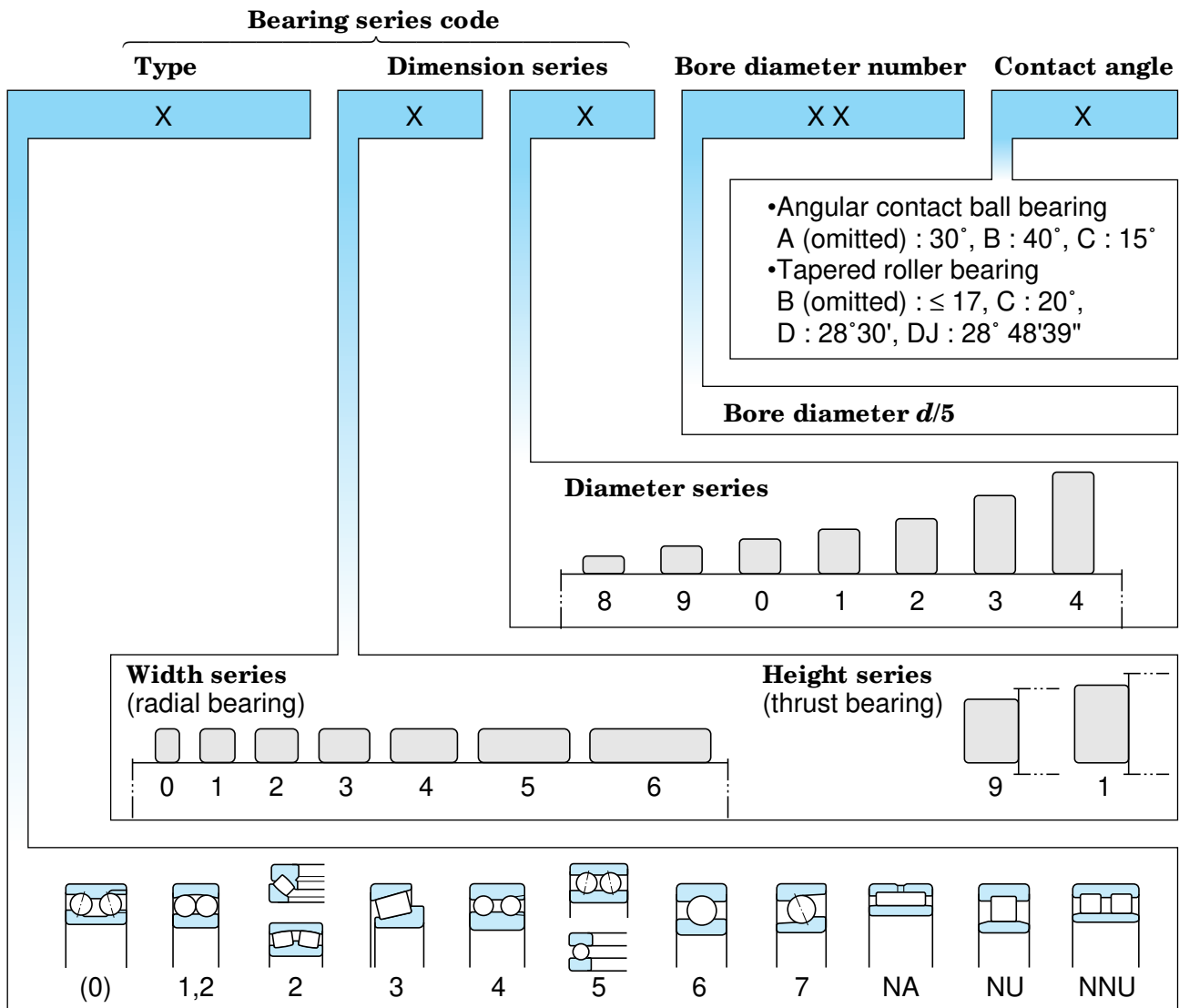

Type code

Type

- (0) Angular contact ball bearing (double-row)
- 1 Self-aligning ball bearing
- 2 Self-aligning ball bearing, Spherical roller bearing and Spherical thrust roller bearing
- 3 Tapered roller bearing
- 4 Deep groove ball bearing (double-row)
- 5 Thrust ball bearing, Angular contact ball bearing (double-row)
- 6 Deep groove ball bearing (single-row)
- 7 Angular contact ball bearing (single-row)
- NA Needle roller bearing (single-row, double-row)
- N, NU Cylindrical roller bearing (single-row)
- NN, NNU Cylindrical roller bearing (double-low)

4. Handling of bearings

4-1 General instructions

Since rolling bearings are more precisely made than other machine parts, careful handling is absolutely necessary.

- 1) Keep bearings and the operating environment clean.
- 2) Handle carefully.
Bearings can be cracked and brinelled easily by strong impact if handled roughly.
- 3) Handle using the proper tools.
- 4) Keep bearings well protected from rust.
Do not handle bearings in high humidity. Operators should wear gloves in order not to soil bearings with perspiration from their hands.
- 5) Bearings should be handled by experienced or well trained operators.
- 6) Set bearing operation standards and follow them.
 - Storage of bearings
 - Cleaning of bearings and their adjoining parts
 - Inspection of dimensions of adjoining parts and finish conditions
 - Mounting
 - Inspection after mounting
 - Dismounting
 - Maintenance and inspection (periodical inspection)
 - Replenishment of lubricants

4-2 Storage of bearings

In shipping bearings, since they are covered with proper anti-corrosion oil and are wrapped in antitarnish paper, the quality of the bearings is guaranteed as long as the wrapping paper is not damaged.

If bearings are to be stored for a long time, it is advisable that the bearings be stored on shelves set higher than 30 cm from the floor, at a humidity less than 65%, and at a temperature around 20°C.

Avoid storage in places exposed directly to the sun's rays or placing boxes of bearings against cold walls.

4-3 Bearing mounting

4-3-1 Recommended preparation prior to mounting

1) Preparation of bearings

Wait until just before mounting before

removing the bearings from their packaging to prevent contamination and rust.

Since the anti-corrosion oil covering bearings is a highly capable lubricant, the oil should not be cleaned off if the bearings are pre-lubricated, or when the bearings are used for normal operation. However, if the bearings are used in measuring instruments or at high rotation speed, the anti-corrosion oil should be removed using a clean detergent oil. After removal of the anti-corrosion oil, bearings should not be left for a long time because they rust easily.

2) Inspection of shafts and housings

Clean up the shaft and housing to check whether it has flaws or burrs as a result of machining.

Be very careful to completely remove lapping agents (SiC, Al₂O₃, etc.), casting sands, and chips from inside the housing.

Next, check that the dimensions, forms, and finish conditions of the shaft and the housing are accurate to those specified on the drawing.

The shaft diameter and housing bore diameter should be measured at the several points as shown in Fig. 4-1 and 4-2.

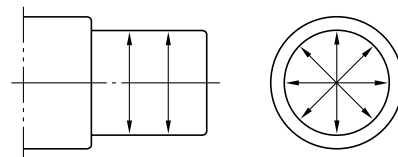

Fig. 4-1 Measuring points on shaft diameter

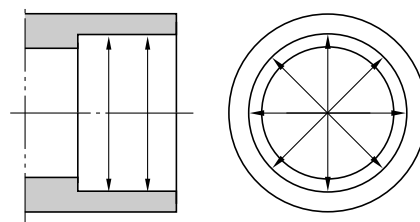

Fig. 4-2 Measuring points on housing bore diameter

Furthermore, fillet radius of shaft and housing, and the squareness of shoulders should be checked.

When using shaft and housing which have passed inspection, it is advisable to apply machine oil to each fitting surface just before mounting.

4-3-2 Bearing mounting

Mounting procedures depend on the type and fitting conditions of bearings.

For general bearings in which the shaft rotates, an interference fit is applied to inner rings, while a clearance fit is applied to outer rings.

For bearings in which the outer rings rotate, an interference fit is applied to the outer rings.

Interference fitting is roughly classified as shown here. The detailed mounting processes are described in Tables 4-1 to 4-3.

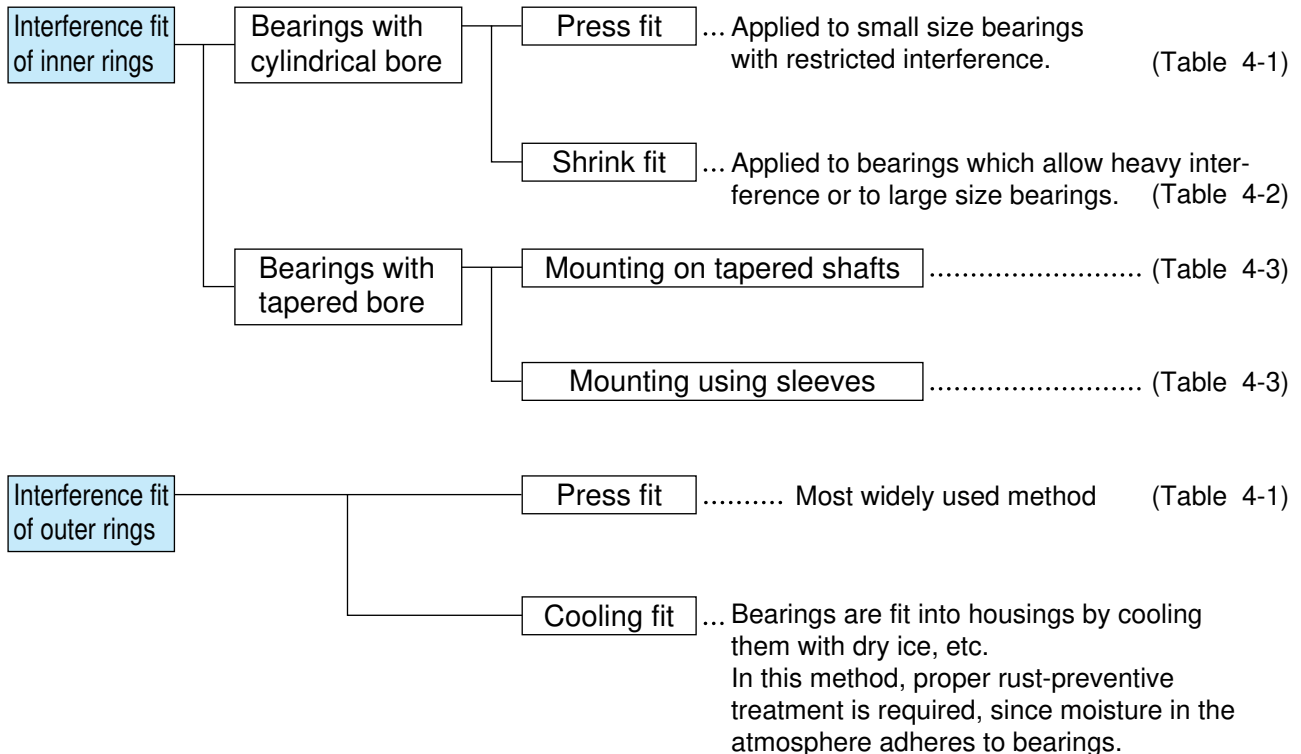

Reference Force is necessary to press fit or remove bearings

The force necessary to press fit or remove inner rings of bearings differs depending on the finish of shafts and how much interference the bearings allow.

The standard values can be obtained by using the following equations.

$$(Solid shafts) \quad K_a = 9.8f_k \cdot \Delta d_{eff} \cdot B \left[1 - \frac{d^2}{D_i^2} \right] \times 10^3 \dots\dots\dots (4-1)$$

$$(Hollow shafts) \quad K_a = 9.8f_k \cdot \Delta d_{eff} \cdot B \frac{\left[1 - \frac{d^2}{D_i^2} \right] \left[1 - \frac{d_0^2}{d^2} \right]}{\left[1 - \frac{d_0^2}{D_i^2} \right]} \times 10^3 \dots\dots\dots (4-2)$$

Remark) For meaning of symbols, see page A 24.

Table 4-1 Press fit of bearings with cylindrical bores

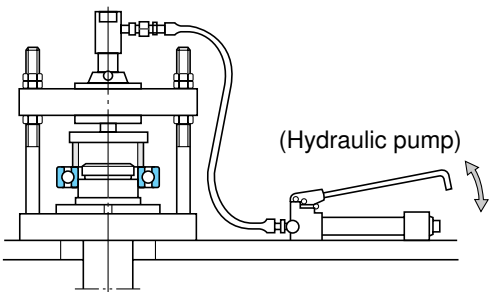
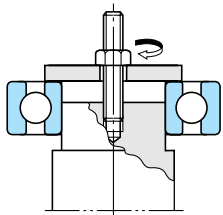
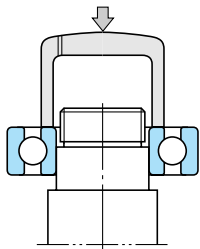
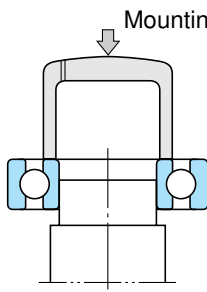
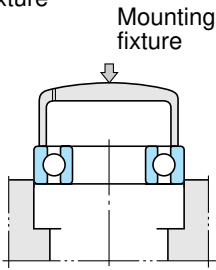
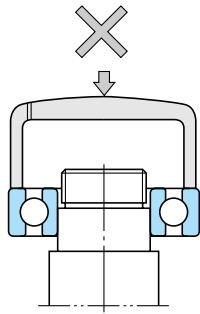
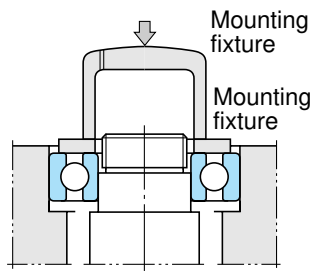
Mounting methods	Descriptions
 <p>(a) Using press fit (the most widely used method)</p>  <p>(b) Using bolts and nuts (screw hole should be provided at the shaft end)</p>  <p>(c) Using hammers (only when there is no alternative measure)</p>	<p>■ As shown in the Fig., a bearing should be mounted slowly with care, by using a fixture to apply force evenly to the bearing. When mounting the inner ring, apply pressure to the inner ring only. Similarly, in mounting the outer ring, press only the outer ring.</p> <div style="display: flex; justify-content: space-around; align-items: center;"> <div style="text-align: center;">  <p>Inner ring press fit</p> </div> <div style="text-align: center;">  <p>Outer ring press fit</p> </div> <div style="text-align: center;">  <p>Inner ring press fit</p> </div> </div> <p>■ If interference is required on both the inner and outer ring of nonseparable bearings, use two kinds of fixtures as shown in the Fig. and apply force carefully, as rolling elements are easily damaged. Be sure never to use a hammer in such cases.</p> <div style="text-align: center;">  <p>Simultaneous press fit of inner ring and outer ring</p> </div>



In equations (4-1) and (4-2) in page A 23.

K_a : force necessary for press fit or removal	N
Δd_{eff} : effective interference	mm
f_k : resistance coefficient	
Coefficient taking into consideration friction between shafts and inner rings ... refer to the table on the right	
B : nominal inner ring width	mm
d : nominal inner ring bore diameter	mm
D_i : average outside diameter of inner ring	mm
d_0 : hollow shaft bore diameter	mm

Value of resistance coefficient f_k

Conditions	f_k
• Press fitting bearings on to cylindrical shafts	4
• Removing bearings from cylindrical shafts	6
• Press fitting bearings on to tapered shafts or tapered sleeves	5.5
• Removing bearings from tapered shafts or tapered sleeves	4.5
• Press fitting tapered sleeves between shafts and bearings	10
• Removing tapered sleeves from the space between shafts and bearings	11

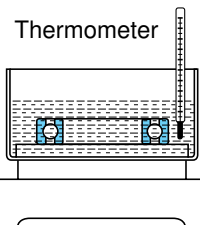
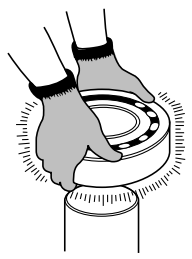
Table 4-2 Shrink fit of cylindrical bore bearings

Shrink fit	Descriptions
<p>Thermometer</p>  <p>(a) Heating in an oil bath</p>	<p>■ This method, which expands bearings by heating them in oil, has the advantage of not applying too much force to bearings and taking only a short time.</p>  <p>(Notes)</p> <ul style="list-style-type: none"> • Oil temperature should not be higher than 100°C, because bearings heated at higher than 120°C lose hardness. • Heating temperature can be determined from the bore diameter of a bearing and the interference by referring to Fig. 4-3. • Use nets or a lifting device to prevent the bearing from resting directly on the bottom of the oil container. • Since bearings shrink in the radial direction as well as the axial direction while cooling down, fix the inner ring and shaft shoulder tightly with the shaft nut before shrinking, so that no space is left between them. <p>■ Shrink fit proves to be clean and effective since, by this method, the ring can be provided with even heat in a short time using neither fire nor oil.</p> <p style="border: 1px solid black; padding: 5px; display: inline-block;">When electricity is being conducted, the bearing itself generates heat by its electrical resistance, aided by the built-in exciting coil.</p> <p>■ For cylindrical roller bearings used in roll necks of rolling mills and railway rolling stock axle journals, where rings are frequently mounted and dismounted, it is advisable for Koyo special induction heaters (with automatic demagnetizers) to be used to fit inner rings.</p>
 <p>(b) Induction heater</p> <p style="border: 1px solid black; padding: 5px; display: inline-block;">This photograph shows a special machine for fitting the inner rings of cylindrical roller bearings.</p>	

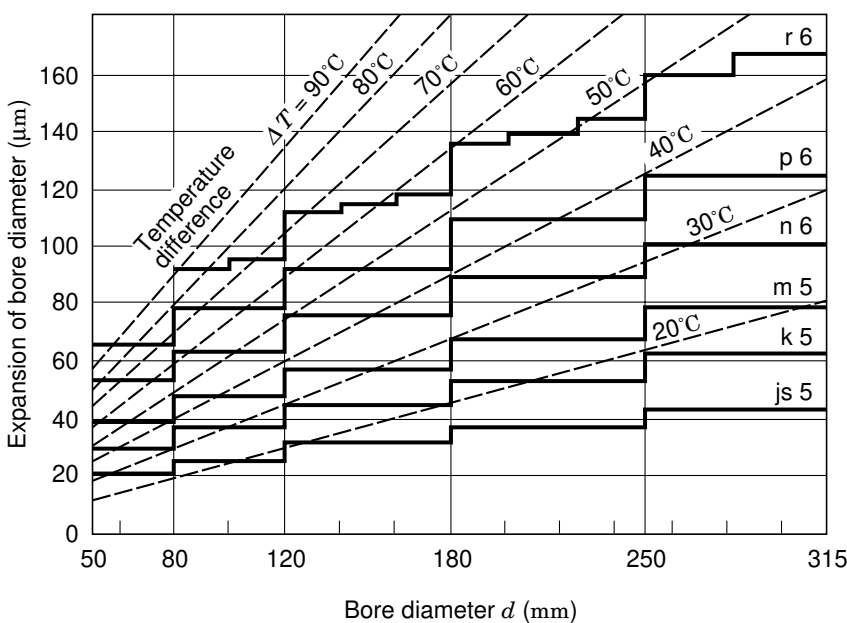

Remarks)

1. Thick solid lines show the maximum interference value between bearings (class 0) and shafts (r6, p6, n6, m5, k5, js5) at normal temperature.

2. Therefore, the heating temperature should be selected to gain a larger "expansion of the bore diameter" than the maximum interference values.

When fitting class 0 bearings having a 90 mm bore diameter to m 5 shafts, this figure shows that heating temperature should be 40°C higher than room temperature to produce expansion larger than the maximum interference value of 48 µm. However, taking cooling during mounting into consideration, the temperature should be set 20 to 30°C higher than the temperature initially required.

Fig. 4-3 Heating temperature and expansion of inner rings

Table 4-3 Mounting bearings with tapered bores

Mounting methods	Descriptions
<div style="text-align: center;">  <p>① Locknut ② Hydraulic nut</p> <p>(a) Mounting on tapered shafts</p> </div> <div style="text-align: center; margin-top: 20px;">  <p>① Locknut ② Hydraulic nut</p> <p>(b) Mounting by use of an adapter</p> </div> <div style="text-align: center; margin-top: 20px;">  <p>① Locknut ② Hydraulic nut</p> <p>(c) Mounting by use of a withdrawal sleeve</p> </div> <div style="text-align: center; margin-top: 20px;">  <p>(d) Measuring clearances</p> </div>	<ul style="list-style-type: none"> ■ When mounting bearings directly on tapered shafts, provide oil holes and grooves on the shaft and inject high pressure oil into the space between the fitting surfaces (oil injection). Such oil injection can reduce tightening torque of locknut by lessening friction between the fitting surfaces. ■ When exact positioning is required in mounting a bearing on a shaft with no shoulder, use a clamp to help determine the position of the bearing. <div style="text-align: center; margin: 10px 0;">  <p>Locating bearing by use of a clamp</p> </div> <ul style="list-style-type: none"> ■ When mounting bearings on shafts, locknuts are generally used. Special spanners are used to tighten them. Bearings can also be mounted using hydraulic nuts. <div style="text-align: center; margin: 10px 0;">  <p>Special spanner</p> </div> <ul style="list-style-type: none"> ■ When mounting tapered bore spherical roller bearings, the reduction in the radial internal clearance which gradually occurs during operation should be taken into consideration as well as the push-in depth described in Table 4-4. <p style="margin-top: 10px;">Clearance reduction can be measured by a thickness gage. First, stabilize the roller in the proper position and then insert the gage into the space between the rollers and the outer ring. Be careful that the clearance between both roller rows and the outer rings is roughly the same ($e \doteq e'$). Since the clearance may differ at different measuring points, take measurements at several positions.</p> <ul style="list-style-type: none"> ■ When mounting self-aligning ball bearings, leave enough clearance to allow easy aligning of the outer ring.

Table 4-4 Mounting tapered bore spherical roller bearings

Nominal bore diameter <i>d</i> mm		Reduction of radial internal clearance μm		Axial displacement, mm				Minimum required residual clearance, μm		
				1/12 taper		1/30 taper		CN clearance	C3 clearance	C4 clearance
over	up to	min.	max.	min.	max.	min.	max.			
24	30	15	20	0.27	0.35	—	—	10	20	35
30	40	20	25	0.32	0.4	—	—	15	25	40
40	50	25	35	0.4	0.5	—	—	20	30	45
50	65	30	40	0.45	0.6	—	—	25	35	55
65	80	35	50	0.55	0.75	—	—	35	40	70
80	100	40	55	0.65	0.85	—	—	40	50	85
100	120	55	70	0.85	1.05	2.15	2.65	45	65	100
120	140	65	90	1.0	1.2	2.5	3.0	55	80	110
140	160	75	100	1.1	1.35	2.75	3.4	55	90	130
160	180	80	110	1.2	1.5	3.0	3.8	60	100	150
180	200	90	120	1.4	1.7	3.5	4.3	70	110	170
200	225	100	130	1.55	1.85	3.85	4.6	80	120	190
225	250	110	140	1.7	2.05	4.25	5.1	90	130	210
250	280	120	160	1.8	2.3	4.5	5.75	100	140	230
280	315	130	180	2.0	2.5	5.0	6.25	110	150	250
315	355	150	200	2.3	2.8	5.75	7.0	120	170	270
355	400	170	220	2.5	3.1	6.25	7.75	130	190	300
400	450	190	240	2.8	3.4	7.0	8.5	140	210	330
450	500	210	270	3.1	3.8	7.75	9.5	160	230	360
500	560	240	310	3.5	4.3	8.75	10.8	170	260	370
560	630	260	350	3.9	4.8	9.75	12.0	200	300	410
630	710	300	390	4.3	5.3	10.8	13.3	210	320	460
710	800	340	430	4.8	6.0	12.0	15.0	230	370	530
800	900	370	500	5.3	6.7	13.3	16.8	270	410	570
900	1 000	410	550	5.9	7.4	14.8	18.5	300	450	640

Remark) The values for reduction of radial internal clearance listed above are values obtained when mounting bearings with CN clearance on solid shafts. In mounting bearings with C3 clearance, the maximum value listed above should be taken as the standard.

4-4 Test run

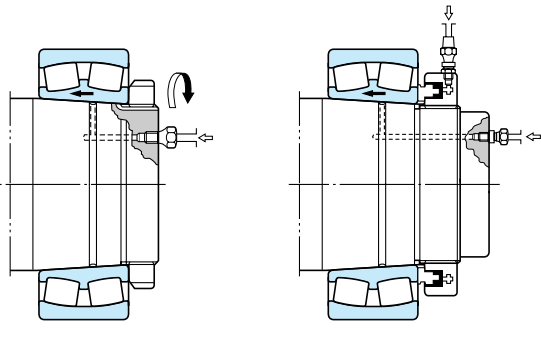
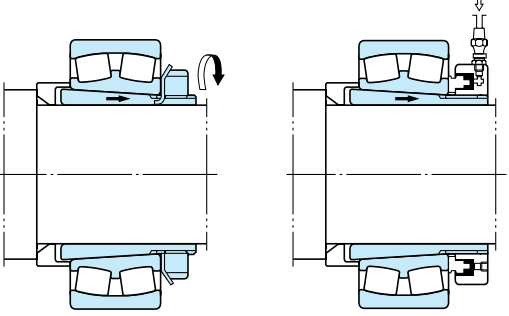
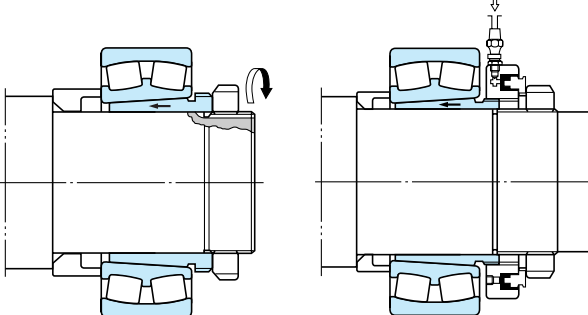
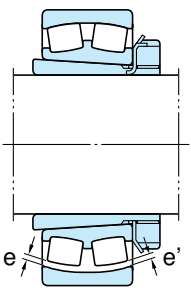
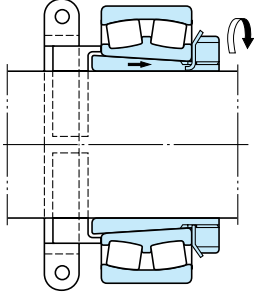
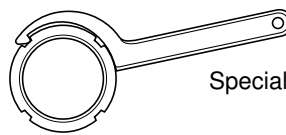
A trial operation is conducted to insure that the bearings are properly mounted.

In the case of compact machines, rotation may be checked by manual operation at first.

If no abnormalities, such as those described below, are observed, then further trial operation proceeds using a power source.

- Knocking ...
due to flaws or insertion of foreign matter on rolling contact surfaces.
- Excessive torque (heavy) ...
due to friction on sealing devices, too small clearances, and mounting errors.

- Uneven running torque ...
due to improper mounting and mounting errors.

For machines too large to allow manual operation, idle running is performed by turning off the power source immediately after turning it on. Before starting power operation, it must be confirmed that bearings rotate smoothly without any abnormal vibration and noise.

Power operation should be started under no load and at low speed, then the speed is gradually increased until the designed speed is reached.

During power operation, check the noise, increase in temperature and vibration.

If any of the abnormalities listed in Tables 4-5 and 4-6 are found, operation must be stopped, and inspection for defects immediately conducted.

The bearings should be dismantled if necessary.

Table 4-5 Bearing noises, causes, and countermeasures

Noise types		Causes	Countermeasures
Cyclic	Flaw noise (similar to noise when punching a rivet) Rust noise Brinelling noise (unclear siren-like noise)	Flaw on raceway Rust on raceway Brinelling on raceway	Improve mounting procedure, cleaning method and rust preventive method. Replace bearing.
	Flaking noise [similar to a large hammering noise]	Flaking on raceway	Replace bearing.
Not cyclic	Dirt noise (an irregular sandy noise)	Insertion of foreign matter	Improve cleaning method, sealing device. Use clean lubricant. Replace bearing.
	Fitting noise [drumming or hammering noise]	Improper fitting or excessive bearing clearance	Review fitting and clearance conditions. Provide preload. Improve mounting accuracy.
	Flaw noise, rust noise, flaking noise	Flaws, rust and flaking on rolling elements	Replace bearing.
	Squeak noise (often heard in cylindrical roller bearings with grease lubrication, especially in winter or at low temperatures)	If noise is caused by improper lubrication, a proper lubricant should be selected. In general, however, serious damage will not be caused by an improper lubricant if used continuously.	
Others	Abnormally large metallic sound	Abnormal load Incorrect mounting Insufficient amount of or improper lubricant	Review fitting, clearance. Adjust preload. Improve accuracy in processing and mounting shafts and housings. Improve sealing device. Refill lubricant. Select proper lubricant.

Table 4-6 Causes of and countermeasures for abnormal temperature rise

Causes	Countermeasures
Too much lubricant	Reduce lubricant amount. Use grease of lower consistency.
Insufficient lubricant	Refill lubricant.
Improper lubricant	Select proper lubricant.
Abnormal load	Review fitting and clearance conditions and adjust preload.
Improper mounting (excessive friction)	Improve accuracy on processing and mounting shaft and housing. Review fitting. Improve sealing device.

Normally, listening rods are employed for bearing noise inspections.

The Koyo Bearing Checker, which detects abnormalities through sound vibration, and the Koyo AE Diagnosis System of Bearings, which utilizes acoustic emission for abnormality detection, are useful for more precise inspection.

In general, bearing temperature can be estimated from housing temperature, but the most accurate method is to measure the temperature of outer rings directly via lubrication holes.

Normally, bearing temperature begins to rise gradually when operation is just starting; and, unless the bearing has some abnormality, the temperature stabilizes within one or two hours.

Therefore, a rapid rise in temperature or unusually high temperature indicates some abnormality.

4-5 Bearing dismantling

After dismantling bearings, handling of the bearings and the various methods available for this should be considered.

If the bearing is to be disposed of, any simple method such as torch cutting can be employed. If the bearing is to be reused or checked for the causes of its failure, the same amount of care as in mounting should be taken in dismantling so as not to damage the bearing and other parts.

Since bearings with interference fits are easily damaged during dismantling, measures to prevent damage during dismantling must be incorporated into the design.

It is recommended that dismantling devices be designed and manufactured, if necessary.

It is useful for discovering the causes of failures when the conditions of bearings, including mounting direction and location, are recorded prior to dismantling.

Dismounting method

Tables 4-7 to 4-9 describe dismantling methods for interference fit bearings intended for reuse or for failure analysis.

The force necessary to remove bearings can be calculated using the equations given on page A 23.

Table 4-7 Dismounting of cylindrical bore bearings

Inner ring dismantling methods	Descriptions
 <p>(a) Dismounting by use of a press</p> <p>(b) Dismounting by use of special tools</p> <p>(c) Dismounting by use of special tools</p> <p>(d) Dismounting using induction heater</p>	<ul style="list-style-type: none"> ■ Non-separable bearings should be treated carefully during dismantling so as to minimize external force, which affects their rolling elements. ■ The easiest way to remove bearings is by using a press as shown in Fig.(a). It is recommended that the fixture be prepared so that the inner ring can receive the removal force. ■ Figs.(b) and (c) show a dismantling method in which special tools are employed. In both cases, the jaws of the tool should firmly hold the side of the inner ring. ■ Fig.(d) shows an example of removal by use of an induction heater: this method can be adapted to both mounting and dismantling of the inner rings of NU and NJ type cylindrical roller bearings. The heater can be used for heating and expanding inner rings in a short time.

Table 4-8 Dismounting tapered bore bearings

Inner ring dismounting methods	Descriptions
<div style="display: flex; justify-content: space-around;"> <div style="text-align: center;">  <p>(a) Dismounting by use of a wedge</p> </div> <div style="text-align: center;">  <p>(b) Dismounting by use of oil pressure</p> </div> </div> <div style="display: flex; justify-content: space-around; margin-top: 20px;"> <div style="text-align: center;">  <p>(c) Dismounting by use of clamps</p> </div> <div style="text-align: center;">  <p>(d) Dismounting by use of hydraulic nuts</p> </div> </div> <div style="display: flex; justify-content: space-around; margin-top: 20px;"> <div style="text-align: center;">  <p>(e) Dismounting by use of locknuts</p> </div> <div style="text-align: center;">  <p>(f) Dismounting by use of bolts</p> </div> <div style="text-align: center;">  <p>(g) Dismounting by use of hydraulic nuts</p> </div> </div>	<ul style="list-style-type: none"> ■ Fig.(a) shows the dismounting of an inner ring by means of driving wedges into notches at the back of the labyrinth. Fig.(b) shows dismounting by means of feeding high pressure oil to the fitting surfaces. In both cases, it is recommended that a stopper (ex. shaft nuts) be provided to prevent bearings from suddenly dropping out. ■ For bearings with an adapter sleeve, the following two methods are suitable. As shown in Fig.(c), fix bearings with clamps, loosen locknuts, then hammer off the adapter sleeve. This method is mainly used for small size bearings. Fig.(d) shows the method using hydraulic nuts. ■ Small size bearings with withdrawal sleeves can be removed by tightening locknuts as shown in Fig.(e). For large size bearings, provide several bolt holes on locknuts as shown in Fig.(f), and tighten bolts. The bearings can then be removed as easily as small size bearings. ■ Fig.(g) shows the method using hydraulic nuts.

Table 4-9 Dismounting of outer rings

Outer ring dismounting methods	Description
<div style="display: flex; justify-content: space-around;"> <div style="text-align: center;">  <p>(a) Notches for dismounting</p> </div> <div style="text-align: center;">  <p>(b) Bolt holes and bolts for dismounting</p> </div> </div>	<ul style="list-style-type: none"> ■ To dismount outer rings with interference fits, it is recommended that notches or bolt holes be provided on the shoulder of the housings.

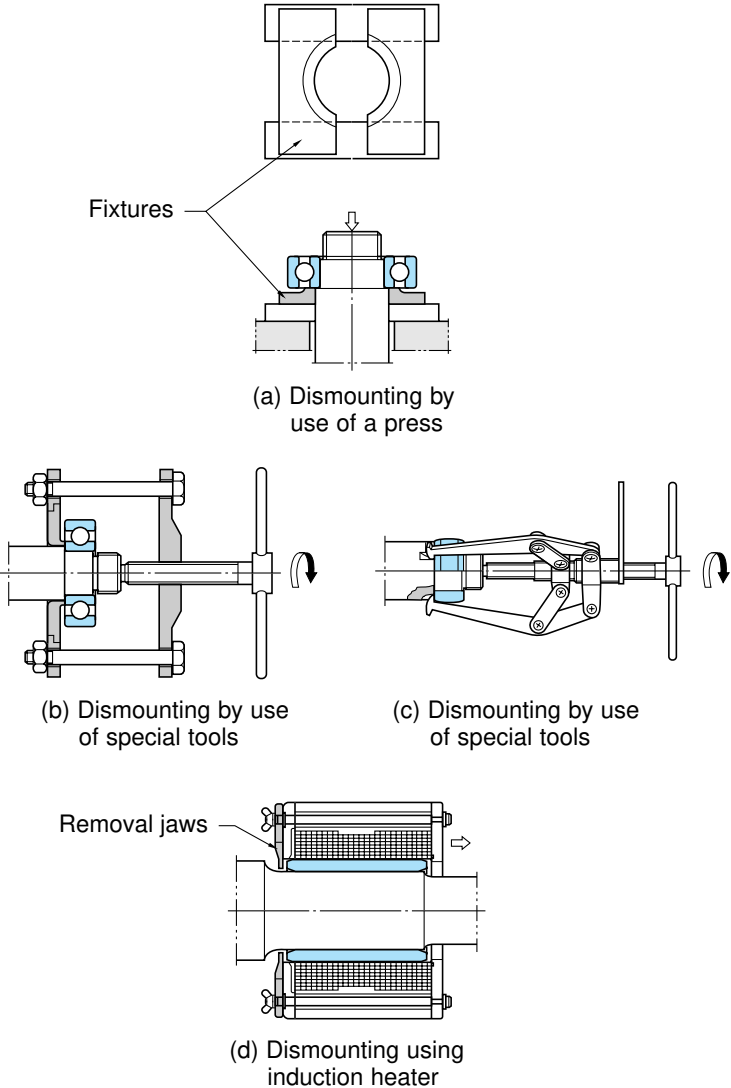
4-6 Maintenance and inspection of bearings

Periodic and thorough maintenance and inspection are indispensable to drawing full performance from bearings and lengthening their useful life.

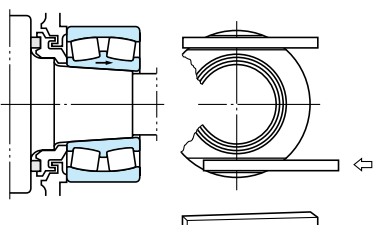
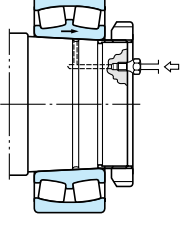
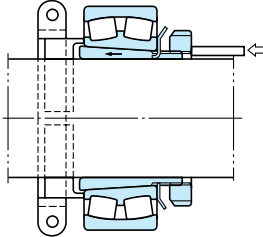
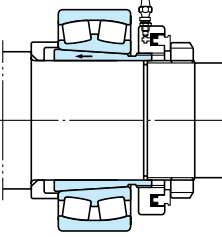
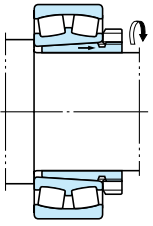
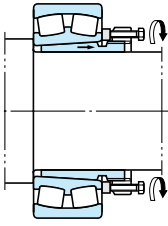
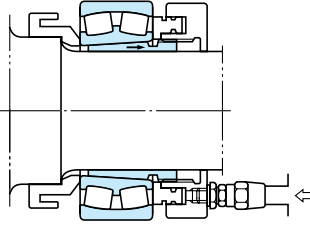
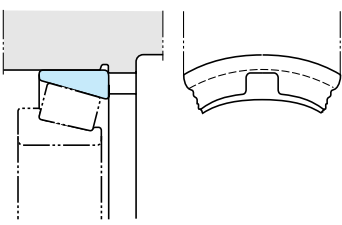
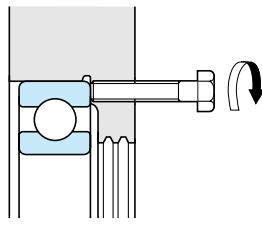
Besides, prevention of accidents and down time by early detection of failures through maintenance and inspection greatly contributes to the enhancement of productivity and profitability.

4-6-1 Cleaning

Before dismounting a bearing for inspection, record the physical condition of the bearing, including taking photographs.

Cleaning should be done after checking the amount of remaining lubricant and collecting lubricant as a sample for examination.

- A dirty bearing should be cleaned using two cleaning processes, such as rough cleaning and finish cleaning. It is recommended that a net be set on the bottom of cleaning containers.
- In rough cleaning, use brushes to remove grease and dirt. Bearings should be handled carefully. Note that raceway surfaces may be damaged by foreign matter, if bearings are rotated in cleaning oil.
- During finish cleaning, clean bearings carefully by rotating them slowly in cleaning oil.

In general, neutral water-free light oil or kerosene is used to clean bearings, a warm alkali solution can also be used if necessary. In any case, it is essential to keep oil clean by filtering it prior to cleaning.

Apply anti-corrosion oil or rust preventive grease on bearings immediately after cleaning.

4-6-2 Inspection and analysis

Before determining that dismounted bearings will be reused, the accuracy of their dimensions and running, internal clearance, fitting surfaces, raceways, rolling contact surfaces, cages and seals must be carefully examined, so as to confirm that no abnormality is present.

It is desirable for skilled persons who have sufficient knowledge of bearings to make decisions on the reuse of bearings.

Criteria for reuse differs according to the performance and importance of machines and inspection frequency.

If the following defects are found, replace the bearing with a new one.

- Cracks and chips in bearing components
- Flaking on the raceway surfaces and the rolling contact surfaces
- Other failures of a serious degree

4-7 Methods of analyzing bearing failures

It is important for enhancing productivity and profitability, as well as for accident prevention that abnormalities in bearings are detected during operation.

Representative detection methods are described in the following section.

1) Noise checking

Since the detection of abnormalities in bearings from noises requires ample experience, sufficient training must be given to inspectors. Given this, it is recommended that specific persons be assigned to this work in order to gain this experience.

Attaching hearing aids or listening rods on housings is effective for detecting bearing noise.

2) Checking of operating temperature

Since this method utilizes change in operating temperature, its application is limited to relatively stable operations.

For detection, operating temperatures must be continuously recorded.

If abnormalities occur in bearings, operating temperature not only increase but also change irregularly.

It is recommended that this method be employed together with noise checking.

3) Lubricant checking

This method detects abnormalities from the foreign matter, including dirt and metallic powder, in lubricants collected as samples.

This method is recommended for inspection of bearings which cannot be checked by close visual inspection, and large size bearings.

Bearing specification tables

Contents

Deep groove ball bearings	B 2	Ball bearing units	B 98
Single-row		Pillow block type	
Open / shielded / sealed type	B 6	Set screw locking	B104
Snap ring groove / locating snap ring type ..	B12	Adapter locking	B106
Extra-small, miniature ball bearings		Thick section pillow block type	B108
Open / shielded / sealed type	B14	Rhombic-flanged type	B110
Double-row	B15	Square-flanged type	B112
Angular contact ball bearings	B16	Round-flanged type with spigot joint	B114
Single-row	B24	Square-flanged type with spigot joint ...	B116
Double-row	B32	Take-up type	B118
Self-aligning ball bearings	B34	Cartridge type	B120
Open / sealed type	B36	Light duty	B121
Adapter assemblies	B40	"Clean" series	B123
Cylindrical roller bearings	B42	Pressed steel housing units	B125
Tapered roller bearings	B50	Ball bearings for units	
Metric series	B54	Cylindrical bore type (set screw locking) ..	B128
Inch series	B60	Tapered bore type (adapter locking) ..	B130
Spherical roller bearings	B70	Locknuts and lockwashers	B132
Spherical roller bearings	B74	Locknuts	B134
Adapter assemblies	B82	Lockwashers	B137
Thrust ball bearings	B88		
Spherical thrust roller bearings	B94		

KOYO



Deep groove ball bearings

Deep groove ball bearings are available in a variety of sizes, and are the most popular of all rolling bearings. This type of bearing supports radial load and a certain degree of axial load in both directions simultaneously.

- Shielded / sealed type
 - Simplifies sealing structure of applications.
 - Greasing is not necessary because bearings are pre-lubricated.
 - Table 1 on the next page lists major shielded and sealed bearing types and compares their performance.
- With locating snap ring
 - Bearings with a locating snap ring can be fit to the housing easily, as the locating snap ring facilitates axial positioning.
- Extra-small ball bearings and miniature ball bearings
 - The open type is widely used. Also available are the shielded / sealed type and the flanged type; the latter is easily positioned in the axial direction.

Single-row deep groove ball bearings

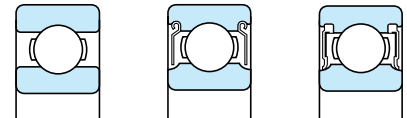

Open type

Shielded type

Sealed type

Bore diameter **10 – 200 mm**

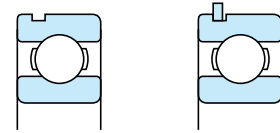

With snap ring groove With locating snap ring

Bore diameter **10 – 130 mm**

Extra-small ball bearings and miniature ball bearings



Bore diameter **3 – 9 mm**

Double-row deep groove ball bearings

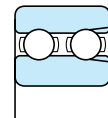

(with filling slot)

Bore diameter **15 – 75 mm**

Deep groove ball bearings

Table 1 Comparison of shielded and sealed bearing performance

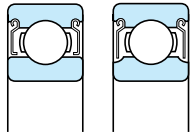
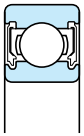
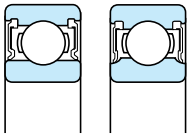
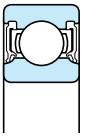
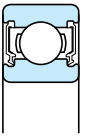
Type	Shielded		Sealed				
	Non-contact type		Non-contact type	Contact type		Extremely light contact type	
	ZZ		2RU	2RS	2RK	2RD	
							
Characteristics	(a) ¹⁾	(b)	(c)	(d) ²⁾	(e)	(f)	(g)
Friction torque	Small		Small	Large		Large	Small
High speed performance	Good		Good	Limited because of contact		Good	Good
Grease sealing property	Good		Better than ZZ type	Better than 2RU type for low-speed applications	Excellent		Excellent
Dirt resistance	Good		Better than ZZ type	Better than 2RU type	Excellent		Excellent
Water resistance	Economical		Better than ZZ type but inferior to 2RS, 2RK and 2RD types	Good		Excellent	Better than ZZ and 2RU types
Operating temperature ³⁾	-30 to 110°C			-30 to 100°C		-30 to 110°C	

Notes)

- 1) Illustration (a) of the ZZ type shows the relatively small size bearing.
- 2) Illustration (d) of the 2RS type shows the relatively small size bearing.
- 3) The operating temperature range listed is for the standard type. It can be widened by using a different type of grease or sealing material. Consult Koyo for details.

Handling instructions

- 1) The shielded / sealed type deep groove ball bearing and the deep groove ball bearing with a locating snap ring are designed for use with the inner ring rotating. Consult koyo on use with the outer ring rotating.
- 2) When the axial load is large, make the shaft shoulder and housing shoulder larger than usual. (Referring to the specification table, make the mounting dimension d_a larger and make D_a smaller.)

Boundary dimensions	The dimensions of standard series are as specified in JIS B 1512. For extra-small and miniature ball bearings, special series (ML) are specified together with those described above.																																																																										
Tolerances	As specified in JIS B 1514.																																																																										
Radial internal clearance	<ul style="list-style-type: none"> ■ Deep groove ball bearings (except extra-small ball bearings and miniature ball bearings) as specified in JIS B 1520 (refer to Table 2-1 on p. A11.) ■ Extra-small ball bearings and miniature ball bearings (refer to Table 2-2 on p. A11.) ■ Deep groove ball bearings for motors (refer to Table 2-6 on p. A14.) 																																																																										
Standard cages	<ul style="list-style-type: none"> • Pressed steel cage (supplementary code : //) • Copper alloy machined cage (supplementary code : FY) <p>Remark : For certain applications, stainless steel sheet pressed cages (YS) and polyamide molded cages (MG) may also be used.</p>	Application of standard cages																																																																									
		<table border="1" style="width: 100%; border-collapse: collapse;"> <thead> <tr> <th style="text-align: center;">Bearing series</th> <th style="text-align: center;">Pressed cage</th> <th style="text-align: center;">Machined cage</th> </tr> </thead> <tbody> <tr><td style="text-align: center;">68</td><td style="text-align: center;">683 – 689</td><td style="text-align: center;">–</td></tr> <tr><td style="text-align: center;">69</td><td style="text-align: center;">693 – 699</td><td style="text-align: center;">–</td></tr> <tr><td style="text-align: center;">60</td><td style="text-align: center;">603 – 609</td><td style="text-align: center;">–</td></tr> <tr><td style="text-align: center;">62</td><td style="text-align: center;">623 – 629</td><td style="text-align: center;">–</td></tr> <tr><td style="text-align: center;">63</td><td style="text-align: center;">633 – 639</td><td style="text-align: center;">–</td></tr> <tr><td colspan="3" style="text-align: center;"> </td></tr> <tr><td style="text-align: center;">68</td><td style="text-align: center;">6800 – 6838</td><td style="text-align: center;">6840 – 68/600</td></tr> <tr><td style="text-align: center;">69</td><td style="text-align: center;">6900 – 6918</td><td style="text-align: center;">6920 – 6980</td></tr> <tr><td style="text-align: center;">160</td><td style="text-align: center;">16001 – 16028</td><td style="text-align: center;">16030 – 16072</td></tr> <tr><td style="text-align: center;">60</td><td style="text-align: center;">6000 – 6034</td><td style="text-align: center;">6036 – 6084</td></tr> <tr><td style="text-align: center;">62</td><td style="text-align: center;">6200 – 6230</td><td style="text-align: center;">6232 – 6248</td></tr> <tr><td style="text-align: center;">63</td><td style="text-align: center;">6300 – 6328</td><td style="text-align: center;">6330 – 6340</td></tr> <tr><td style="text-align: center;">64</td><td style="text-align: center;">6403 – 6418</td><td style="text-align: center;">–</td></tr> <tr><td colspan="3" style="text-align: center;"> </td></tr> <tr><td style="text-align: center;">42</td><td style="text-align: center;">4200 – 4215</td><td style="text-align: center;">–</td></tr> <tr><td style="text-align: center;">43</td><td style="text-align: center;">4302 – 4315</td><td style="text-align: center;">–</td></tr> </tbody> </table>	Bearing series	Pressed cage	Machined cage	68	683 – 689	–	69	693 – 699	–	60	603 – 609	–	62	623 – 629	–	63	633 – 639	–				68	6800 – 6838	6840 – 68/600	69	6900 – 6918	6920 – 6980	160	16001 – 16028	16030 – 16072	60	6000 – 6034	6036 – 6084	62	6200 – 6230	6232 – 6248	63	6300 – 6328	6330 – 6340	64	6403 – 6418	–				42	4200 – 4215	–	43	4302 – 4315	–																						
Bearing series	Pressed cage	Machined cage																																																																									
68	683 – 689	–																																																																									
69	693 – 699	–																																																																									
60	603 – 609	–																																																																									
62	623 – 629	–																																																																									
63	633 – 639	–																																																																									
68	6800 – 6838	6840 – 68/600																																																																									
69	6900 – 6918	6920 – 6980																																																																									
160	16001 – 16028	16030 – 16072																																																																									
60	6000 – 6034	6036 – 6084																																																																									
62	6200 – 6230	6232 – 6248																																																																									
63	6300 – 6328	6330 – 6340																																																																									
64	6403 – 6418	–																																																																									
42	4200 – 4215	–																																																																									
43	4302 – 4315	–																																																																									
Allowable misalignment	0.002 3 – 0.003 4 rad (8' – 12')																																																																										
Equivalent radial load (Single / double-row)	Dynamic equivalent radial load																																																																										
	$P_r = XF_r + YF_a$ <p>[refer to the table on the right for values X and Y.]</p>																																																																										
	Static equivalent radial load																																																																										
	$P_{0r} = 0.6F_r + 0.5F_a$ <p>[when the value of $P_{0r} < F_r$, $P_{0r} = F_r$]</p>																																																																										
	<table border="1" style="width: 100%; border-collapse: collapse;"> <thead> <tr> <th rowspan="2" style="text-align: center;">$\frac{F_a}{C_{0r}}$</th> <th rowspan="2" style="text-align: center;">e</th> <th colspan="2" style="text-align: center;">$\frac{F_a}{F_r} \leq e$</th> <th colspan="2" style="text-align: center;">$\frac{F_a}{F_r} > e$</th> </tr> <tr> <th style="text-align: center;">X</th> <th style="text-align: center;">Y</th> <th style="text-align: center;">X</th> <th style="text-align: center;">Y</th> </tr> </thead> <tbody> <tr><td style="text-align: center;">0.014</td><td style="text-align: center;">0.19</td><td rowspan="3" style="text-align: center;">1</td><td rowspan="3" style="text-align: center;">0</td><td rowspan="3" style="text-align: center;">0.56</td><td style="text-align: center;">2.30</td></tr> <tr><td style="text-align: center;">0.028</td><td style="text-align: center;">0.22</td><td style="text-align: center;">1.99</td></tr> <tr><td style="text-align: center;">0.056</td><td style="text-align: center;">0.26</td><td style="text-align: center;">1.71</td></tr> <tr><td colspan="6" style="text-align: center;"> </td></tr> <tr><td style="text-align: center;">0.084</td><td style="text-align: center;">0.28</td><td></td><td></td><td></td><td style="text-align: center;">1.55</td></tr> <tr><td style="text-align: center;">0.11</td><td style="text-align: center;">0.30</td><td></td><td></td><td></td><td style="text-align: center;">1.45</td></tr> <tr><td style="text-align: center;">0.17</td><td style="text-align: center;">0.34</td><td></td><td></td><td></td><td style="text-align: center;">1.31</td></tr> <tr><td colspan="6" style="text-align: center;"> </td></tr> <tr><td style="text-align: center;">0.28</td><td style="text-align: center;">0.38</td><td></td><td></td><td></td><td style="text-align: center;">1.15</td></tr> <tr><td style="text-align: center;">0.42</td><td style="text-align: center;">0.42</td><td></td><td></td><td></td><td style="text-align: center;">1.04</td></tr> <tr><td style="text-align: center;">0.56</td><td style="text-align: center;">0.44</td><td></td><td></td><td></td><td style="text-align: center;">1.00</td></tr> </tbody> </table>	$\frac{F_a}{C_{0r}}$	e	$\frac{F_a}{F_r} \leq e$		$\frac{F_a}{F_r} > e$		X	Y	X	Y	0.014	0.19	1	0	0.56	2.30	0.028	0.22	1.99	0.056	0.26	1.71							0.084	0.28				1.55	0.11	0.30				1.45	0.17	0.34				1.31							0.28	0.38				1.15	0.42	0.42				1.04	0.56	0.44				1.00				
$\frac{F_a}{C_{0r}}$	e			$\frac{F_a}{F_r} \leq e$		$\frac{F_a}{F_r} > e$																																																																					
		X	Y	X	Y																																																																						
0.014	0.19	1	0	0.56	2.30																																																																						
0.028	0.22				1.99																																																																						
0.056	0.26				1.71																																																																						
0.084	0.28				1.55																																																																						
0.11	0.30				1.45																																																																						
0.17	0.34				1.31																																																																						
0.28	0.38				1.15																																																																						
0.42	0.42				1.04																																																																						
0.56	0.44				1.00																																																																						

Single-row deep groove ball bearings

d 10 – 20 mm

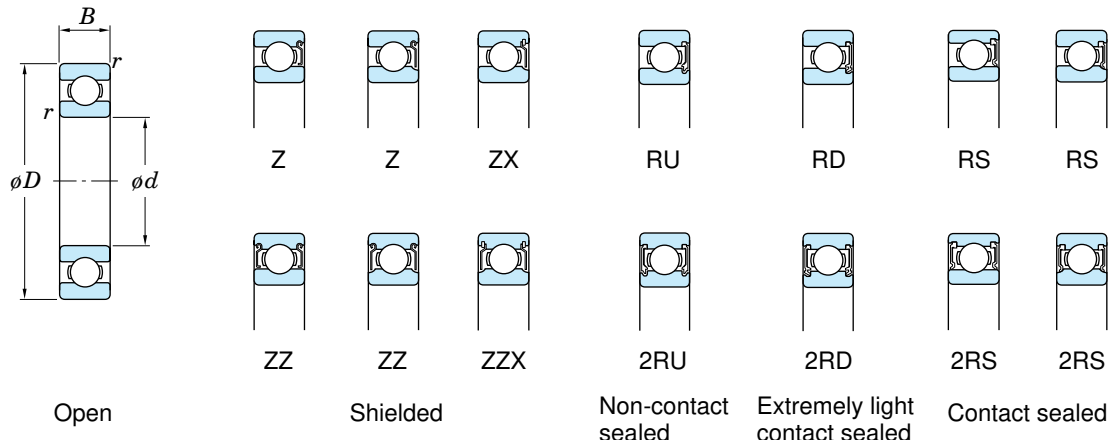

Boundary dimensions (mm)				Basic load ratings (kN)		Limiting speeds (min ⁻¹)				Bearing No.					(Refer.) Mass
d	D	B	r min.	C_r	C_{0r}	Grease lub.		Oil lub.	Open	Shielded ZZ	Sealed 2RU	2RD	2RS	Open type (kg)	
						$\left[\begin{smallmatrix} \text{Open} \\ Z, ZZ \\ RU, 2RU \end{smallmatrix} \right]$	(RD, 2RD)	(RS, 2RS)							$\left[\begin{smallmatrix} \text{Open} \\ Z \end{smallmatrix} \right]$
10	19	5	0.3	1.70	0.84	37 000	–	–	43 000	6800	ZZ	–	–	–	0.005
	22	6	0.3	2.70	1.25	34 000	–	–	41 000	6900	ZZ	–	–	–	0.010
	26	8	0.3	4.55	1.95	31 000	–	19 000	36 000	6000	ZZ	2RU	–	2RS	0.019
	30	9	0.6	5.10	2.40	24 000	–	16 000	29 000	6200	ZZ	2RU	–	2RS	0.032
	35	11	0.6	8.10	3.45	22 000	–	16 000	27 000	6300	ZZ	2RU	–	2RS	0.053
	12	21	5	0.3	1.90	1.05	33 000	–	–	39 000	6801	ZZ	2RU	–	–
24		6	0.3	2.90	1.45	31 000	–	–	36 000	6901	ZZ	2RU	–	–	0.011
28		7	0.3	5.10	2.40	27 000	–	–	32 000	16001	–	–	–	–	0.024
28		8	0.3	5.10	2.40	27 000	–	17 000	32 000	6001	ZZ	2RU	–	2RS	0.022
32		10	0.6	6.80	3.05	22 000	20 000	15 000	27 000	6201	ZZ	2RU	2RD	2RS	0.037
37		12	1	9.70	4.20	20 000	18 000	15 000	25 000	6301	ZZ	2RU	2RD	2RS	0.060
15	24	5	0.3	2.10	1.25	28 000	–	–	33 000	6802	ZZ	2RU	–	–	0.007
	28	7	0.3	4.30	2.25	26 000	–	–	30 000	6902	ZZ	2RU	–	–	0.017
	32	8	0.3	5.60	2.85	23 000	–	–	28 000	16002	–	–	–	–	0.025
	32	9	0.3	5.60	2.85	23 000	–	14 000	27 000	6002	ZZ	2RU	–	2RS	0.030
	35	11	0.6	7.65	3.75	20 000	18 000	13 000	24 000	6202	ZZ	2RU	2RD	2RS	0.045
	42	13	1	11.4	5.45	17 000	15 000	12 000	20 000	6302	ZZ	2RU	2RD	2RS	0.082
17	26	5	0.3	2.60	1.55	26 000	–	–	30 000	6803	ZZ	2RU	–	–	0.008
	30	7	0.3	4.60	2.55	23 000	–	–	28 000	6903	ZZ	2RU	–	–	0.018
	35	8	0.3	6.00	3.25	21 000	–	–	25 000	16003	–	–	–	–	0.032
	35	10	0.3	6.00	3.25	21 000	–	12 000	25 000	6003	ZZ	2RU	–	2RS	0.039
	40	12	0.6	9.55	4.80	17 000	15 000	12 000	21 000	6203	ZZ	2RU	2RD	2RS	0.065
	47	14	1	13.6	6.65	15 000	14 000	10 000	18 000	6303	ZZ	2RU	2RD	2RS	0.115
20	62	17	1.1	20.7	9.85	13 000	–	–	15 000	6403	–	–	–	–	0.270
	32	7	0.3	4.00	2.45	21 000	–	–	25 000	6804	ZZ	2RU	–	–	0.018
	37	9	0.3	6.35	3.70	19 000	–	–	23 000	6904	ZZ	2RU	–	–	0.036
	42	8	0.3	7.95	4.50	17 000	–	–	21 000	16004	–	–	–	–	0.050
	42	12	0.6	9.40	5.05	17 000	–	10 000	21 000	6004	ZZ	2RU	–	2RS	0.069
	47	14	1	12.8	6.65	15 000	14 000	9 700	17 000	6204	ZZ	2RU	2RD	2RS	0.106
52	15	1.1	15.9	7.85	14 000	13 000	9 500	17 000	6304	ZZ	2RU	2RD	2RS	0.144	
72	19	1.1	31.0	15.2	11 000	–	–	13 000	6404	–	–	–	–	0.400	

Remark) Standard cage types used for the above bearings are described earlier in this section.

d 22 – 45 mm

Boundary dimensions (mm)				Basic load ratings (kN)		Limiting speeds (min ⁻¹)				Bearing No.					(Refer.) Mass
d	D	B	r min.	C _r	C _{0r}	Grease lub.			Oil lub.	Open	Shielded ZZ	Sealed 2RU	2RD	2RS	Open type (kg)
						$\left\{ \begin{array}{l} \text{Open} \\ \text{Z, ZZ} \\ \text{RU, 2RU} \end{array} \right\}$	(RD, 2RD)	(RS, 2RS)	$\left\{ \begin{array}{l} \text{Open} \\ \text{Z} \end{array} \right\}$						
22	44	12	0.6	9.40	5.15	17 000	–	9 900	20 000	60/22	–	–	–	2RS	0.073
	50	14	1	12.8	6.65	15 000	–	9 700	17 000	62/22	–	–	–	2RS	0.118
	56	16	1.1	18.5	9.40	13 000	–	8 600	15 000	63/22	–	–	–	2RS	0.201
25	37	7	0.3	4.30	2.95	18 000	–	–	21 000	6805	ZZ	2RU	–	–	0.022
	42	9	0.3	7.00	4.55	16 000	–	–	19 000	6905	ZZ	2RU	–	–	0.041
	47	8	0.3	8.85	5.60	15 000	–	–	18 000	16005	–	–	–	–	0.060
	47	12	0.6	10.1	5.85	15 000	–	9 000	18 000	6005	ZZ	2RU	–	2RS	0.080
	52	15	1	14.0	7.85	13 000	12 000	8 400	15 000	6205	ZZ	2RU	2RD	2RS	0.128
	62	17	1.1	20.6	11.3	11 000	9 900	7 500	13 000	6305	ZZ	2RU	2RD	2RS	0.232
	80	21	1.5	36.1	19.4	9 100	–	–	11 000	6405	–	–	–	–	0.530
28	52	12	0.6	12.4	7.40	14 000	–	–	16 000	60/28	ZZ	–	–	–	0.097
	58	16	1	17.9	9.75	12 000	–	7 600	14 000	62/28	ZZ	–	–	2RS	0.173
	68	18	1.1	23.5	13.1	10 000	–	6 900	12 000	63/28	ZZ	–	–	2RS	0.328
30	42	7	0.3	4.55	3.40	15 000	–	–	18 000	6806	ZZ	2RU	–	–	0.026
	47	9	0.3	7.25	5.00	14 000	–	–	17 000	6906	ZZ	2RU	–	–	0.045
	55	9	0.3	11.2	7.35	13 000	–	–	15 000	16006	–	–	–	–	0.085
	55	13	1	13.2	8.25	13 000	–	7 500	15 000	6006	ZZ	2RU	–	2RS	0.116
	62	16	1	19.5	11.3	11 000	9 900	7 000	13 000	6206	ZZ	2RU	2RD	2RS	0.199
	72	19	1.1	26.7	15.0	9 600	8 600	6 400	12 000	6306	ZZ	2RU	2RD	2RS	0.346
	90	23	1.5	43.4	23.9	8 100	–	–	9 700	6406	–	–	–	–	0.735
32	58	13	1	15.0	9.15	12 000	–	7 200	14 000	60/32	ZZ	–	–	2RS	0.127
	65	17	1	23.5	13.1	10 000	–	6 900	12 000	62/32	ZZ	–	–	2RS	0.228
	75	20	1.1	30.1	16.2	9 300	–	6 400	11 000	63/32	ZZ	–	–	2RS	0.437
35	47	7	0.3	4.75	3.85	13 000	–	–	16 000	6807	ZZ	2RU	–	–	0.030
	55	10	0.6	10.9	7.75	12 000	–	–	14 000	6907	ZZ	2RU	–	–	0.073
	62	9	0.3	12.2	8.85	11 000	–	–	13 000	16007	–	–	–	–	0.110
	62	14	1	15.9	10.3	11 000	–	6 500	13 000	6007	ZZ	2RU	–	2RS	0.155
	72	17	1.1	25.7	15.4	9 200	8 300	6 000	11 000	6207	ZZ	2RU	2RD	2RS	0.288
	80	21	1.5	33.4	19.3	8 500	7 700	5 700	10 000	6307	ZZ	2RU	2RD	2RS	0.457
	100	25	1.5	55.0	31.0	7 200	–	–	8 600	6407	–	–	–	–	0.952
40	52	7	0.3	4.95	4.20	12 000	–	–	14 000	6808	ZZ	2RU	–	–	0.033
	62	12	0.6	13.7	9.95	11 000	–	–	13 000	6908	ZZ	2RU	–	–	0.112
	68	9	0.3	12.6	9.65	9 800	–	–	12 000	16008	–	–	–	–	0.125
	68	15	1	16.7	11.5	10 000	–	5 800	12 000	6008	ZZ	2RU	–	2RS	0.192
	80	18	1.1	29.1	17.8	8 300	7 500	5 400	10 000	6208	ZZ	2RU	2RD	2RS	0.366
	90	23	1.5	40.7	24.0	7 700	6 900	5 100	9 200	6308	ZZ	2RU	2RD	2RS	0.633
	110	27	2	63.7	36.6	6 600	–	–	7 900	6408	–	–	–	–	1.23
45	58	7	0.3	6.20	5.40	11 000	–	–	13 000	6809	ZZ	2RU	–	–	0.040
	68	12	0.6	14.1	10.9	9 700	–	–	11 000	6909	ZZ	2RU	–	–	0.132
	75	10	0.6	15.5	12.3	8 900	–	–	10 000	16009	–	–	–	–	0.170
	75	16	1	21.0	15.1	9 200	–	5 300	11 000	6009	ZZ	2RU	–	2RS	0.245
	85	19	1.1	32.7	20.3	7 700	6 900	5 100	9 200	6209	ZZ	2RU	2RD	2RS	0.407
	100	25	1.5	48.9	29.5	6 800	6 100	4 500	8 100	6309	ZZ	2RU	2RD	2RS	0.833
	120	29	2	77.2	45.1	6 000	–	–	7 200	6409	–	–	–	–	1.53

Remark) Standard cage types used for the above bearings are described earlier in this section.

Single-row deep groove ball bearings

d 50 – (70) mm

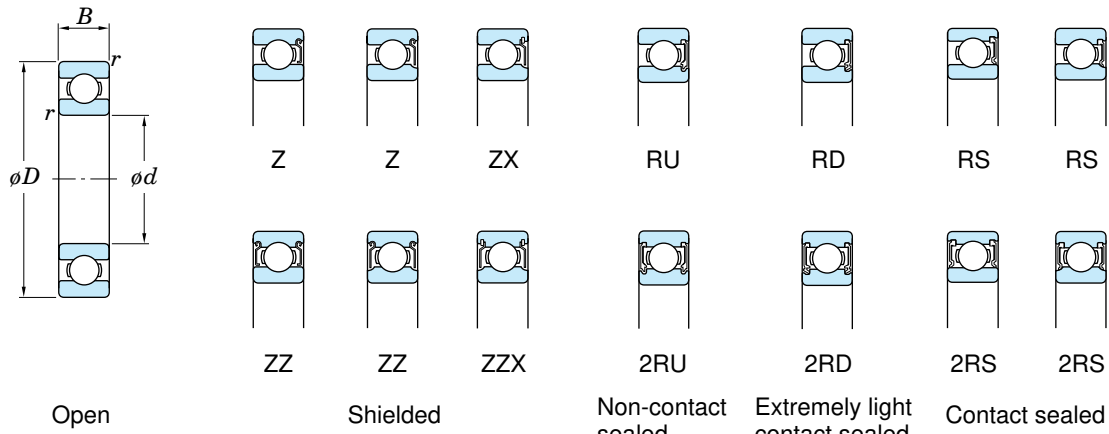

Boundary dimensions (mm)				Basic load ratings (kN)		Limiting speeds (min ⁻¹)				Bearing No.					(Refer.) Mass
d	D	B	r min.	C_r	C_{0r}	Grease lub.			Oil lub.	Open	Shielded ZZ	Sealed 2RU	2RD	2RS	Open type (kg)
						$\left\{ \begin{array}{l} \text{Open} \\ Z, ZZ \\ RU, 2RU \end{array} \right\}$	(RD, 2RD)	(RS, 2RS)	$\left\{ \begin{array}{l} \text{Open} \\ Z \end{array} \right\}$						
50	65	7	0.3	6.60	6.10	9 600	–	–	11 000	6810	ZZ	2RU	–	–	0.052
	72	12	0.6	14.5	11.7	9 000	–	–	11 000	6910	ZZ	2RU	–	–	0.133
	80	10	0.6	16.0	13.3	8 200	–	–	9 700	16010	–	–	–	–	0.180
	80	16	1	21.8	16.6	8 400	–	4 800	9 900	6010	ZZ	2RU	–	2RS	0.261
	90	20	1.1	35.1	23.3	7 100	6 400	4 600	8 500	6210	ZZ	2RU	2RD	2RS	0.463
	110	27	2	62.0	38.3	6 100	5 500	4 100	7 300	6310	ZZ	2RU	2RD	2RS	1.07
	130	31	2.1	83.0	49.5	5 500	–	–	6 600	6410	–	–	–	–	1.88
55	72	9	0.3	8.80	8.10	8 700	–	–	10 000	6811	ZZ	2RU	–	–	0.083
	80	13	1	16.6	14.1	8 100	–	–	9 600	6911	ZZ	2RU	–	–	0.185
	90	11	0.6	19.3	16.3	7 400	–	–	8 800	16011	–	–	–	–	0.260
	90	18	1.1	28.3	21.2	7 600	–	4 300	8 900	6011	ZZ	2RU	–	2RS	0.385
	100	21	1.5	43.4	29.4	6 300	–	4 100	7 600	6211	ZZ	2RU	–	2RS	0.607
	120	29	2	71.6	45.0	5 600	–	3 700	6 700	6311	ZZ	2RU	–	2RS	1.37
	140	33	2.1	100	62.3	5 000	–	–	6 000	6411	–	–	–	–	2.29
60	78	10	0.3	11.5	10.6	8 000	–	–	9 400	6812	ZZ	2RU	–	–	0.104
	85	13	1	20.2	17.3	7 500	–	–	8 900	6912	ZZ	2RU	–	–	0.192
	95	11	0.6	19.8	17.6	6 900	–	–	8 100	16012	–	–	–	–	0.280
	95	18	1.1	29.4	23.2	7 100	–	4 000	8 400	6012	ZZ	2RU	–	2RS	0.415
	110	22	1.5	52.4	36.2	5 700	–	3 700	6 900	6212	ZZ	2RU	–	2RS	0.783
	130	31	2.1	81.9	52.2	5 200	–	3 500	6 200	6312	ZZ	2RU	–	2RS	1.70
	150	35	2.1	110	70.8	4 600	–	–	5 500	6412	–	–	–	–	2.77
65	85	10	0.6	11.9	11.5	7 300	–	–	8 600	6813	ZZ	2RU	–	–	0.126
	90	13	1	17.4	16.1	7 100	–	–	8 400	6913	ZZ	2RU	–	–	0.211
	100	11	0.6	17.1	16.0	6 600	–	–	7 800	16013	–	–	–	–	0.300
	100	18	1.1	30.5	25.2	6 600	–	3 700	7 800	6013	ZZ	2RU	–	2RS	0.435
	120	23	1.5	57.2	40.1	5 400	–	3 500	6 400	6213	ZZ	2RU	–	2RS	0.990
	140	33	2.1	92.7	59.9	4 800	–	3 200	5 800	6313	ZZ	2RU	–	2RS	2.08
	160	37	2.1	118	79.2	4 300	–	–	5 200	6413	–	–	–	–	3.30
70	90	10	0.6	12.1	11.9	6 800	–	–	8 100	6814	ZZ	2RU	–	–	0.134
	100	16	1	23.7	21.2	6 400	–	–	7 600	6914	ZZ	2RU	–	–	0.342
	110	13	0.6	30.1	25.6	6 100	–	–	7 200	16014	–	–	–	–	0.433
	110	20	1.1	38.1	30.9	6 100	–	3 500	7 200	6014	ZZ	2RU	–	2RS	0.602

Remark) Standard cage types used for the above bearings are described earlier in this section.

d (70) – 105 mm

Boundary dimensions (mm)				Basic load ratings (kN)		Limiting speeds (min ⁻¹)				Bearing No.					(Refer.) Mass Open type (kg)
d	D	B	r min.	C _r	C _{0r}	Grease lub.			Oil lub.	Open	Shielded ZZ	Sealed 2RU	2RD	2RS	
						$\left\{ \begin{array}{l} \text{Open} \\ \text{Z, ZZ} \\ \text{RU, 2RU} \end{array} \right\}$	(RD, 2RD)	(RS, 2RS)	$\left\{ \begin{array}{l} \text{Open} \\ \text{Z} \end{array} \right\}$						
70	125	24	1.5	62.2	44.1	5 100	–	3 300	6 100	6214	ZZ	2RU	–	2RS	1.07
	150	35	2.1	104	68.2	4 500	–	3 000	5 400	6314	ZZ	2RU	–	2RS	2.52
	180	42	3	144	104	3 900	–	–	4 600	6414	–	–	–	–	4.83
75	95	10	0.6	12.5	12.9	6 400	–	–	7 600	6815	ZZ	2RU	–	–	0.142
	105	16	1	24.4	22.6	6 100	–	–	7 200	6915	ZZ	2RU	–	–	0.363
	115	13	0.6	27.5	25.3	5 700	–	–	6 700	16015	–	–	–	–	0.457
	115	20	1.1	39.6	33.5	5 700	–	3 300	6 800	6015	ZZ	2RU	–	2RS	0.638
	130	25	1.5	67.4	48.3	4 800	–	3 100	5 800	6215	ZZ	2RU	–	2RS	1.18
	160	37	2.1	113	77.2	4 200	–	2 800	5 000	6315	ZZ	2RU	–	2RS	3.02
80	190	45	3	154	115	3 600	–	–	4 400	6415	–	–	–	–	5.87
	100	10	0.6	12.7	13.3	6 100	–	–	7 200	6816	ZZ	2RU	–	–	0.150
	110	16	1	25.0	24.0	5 700	–	–	6 800	6916	ZZ	2RU	–	–	0.382
	125	14	0.6	31.7	29.7	5 200	–	–	6 100	16016	–	–	–	–	0.597
	125	22	1.1	47.6	39.8	5 300	–	3 100	6 300	6016	ZZ	–	–	2RS	0.850
	140	26	2	72.7	53.0	4 500	–	2 900	5 400	6216	ZZ	–	–	2RS	1.40
	170	39	2.1	123	86.7	3 900	–	2 700	4 700	6316	ZZ	–	–	2RS	3.59
	200	48	3	164	125	3 400	–	–	4 100	6416	–	–	–	–	6.84
	85	110	13	1	18.7	19.0	5 600	–	–	6 600	6817	ZZ	2RU	–	–
120		18	1.1	31.9	29.6	5 300	–	–	6 300	6917	ZZ	2RU	–	–	0.535
130		14	0.6	32.6	31.7	4 900	–	–	5 800	16017	–	–	–	–	0.626
	130	22	1.1	49.5	43.1	5 000	–	2 900	5 900	6017	ZZ	–	–	2RS	0.890
	150	28	2	84.0	61.9	4 200	–	2 700	5 000	6217	ZZ	–	–	2RS	1.79
	180	41	3	133	96.8	3 700	–	2 500	4 400	6317	ZZX	–	–	2RS	4.23
90	210	52	4	173	136	3 300	–	–	3 900	6417	–	–	–	–	8.07
	115	13	1	19.0	19.7	5 300	–	–	6 300	6818	ZZ	2RU	–	–	0.279
	125	18	1.1	32.8	31.6	5 100	–	–	6 000	6918	ZZ	2RU	–	–	0.565
	140	16	1	39.9	37.0	4 700	–	–	5 600	16018	–	–	–	–	0.848
	140	24	1.5	58.2	49.7	4 700	–	2 700	5 600	6018	ZZ	–	–	2RS	1.16
	160	30	2	96.1	71.5	3 900	–	2 600	4 700	6218	ZZ	–	–	2RS	2.15
	190	43	3	143	107	3 500	–	2 400	4 200	6318	ZZX	–	–	2RS	4.91
	225	54	4	184	149	3 100	–	–	3 700	6418	–	–	–	–	9.78
	95	130	18	1.1	33.7	33.5	4 800	–	–	5 700	6919	ZZ	2RU	–	–
145		16	1	41.2	39.6	4 500	–	–	5 300	16019	–	–	–	–	0.885
145		24	1.5	60.4	53.9	4 400	–	2 500	5 200	6019	ZZX	2RU	–	2RS	1.21
	170	32	2.1	109	81.9	3 700	–	2 400	4 400	6219	ZZX	–	–	2RS	2.62
	200	45	3	153	119	3 300	–	2 200	4 000	6319	ZZX	–	–	2RS	5.67
	100	125	13	1	19.6	21.2	4 800	–	–	5 700	6820	ZZ	2RU	–	–
140		20	1.1	45.0	41.9	4 500	–	–	5 300	6920	ZZ	2RU	–	–	0.960
150		16	1	42.4	42.1	4 300	–	–	5 100	16020	–	–	–	–	0.910
	150	24	1.5	60.2	54.2	4 300	–	2 500	5 100	6020	ZZ	–	–	2RS	1.25
	180	34	2.1	122	93.1	3 500	–	2 300	4 200	6220	ZZX	–	–	2RS	3.14
	215	47	3	173	141	3 000	–	2 100	3 600	6320	ZZX	–	–	2RS	7.00
105	145	20	1.1	46.5	44.8	4 300	–	–	5 100	6921	ZZ	–	–	–	1.00
	160	18	1	41.9	42.2	4 100	–	–	4 800	16021	–	–	–	–	1.20
	160	26	2	72.3	65.8	4 000	–	2 300	4 700	6021	ZZX	–	–	2RS	1.59
	190	36	2.1	133	105	3 300	–	2 200	3 900	6221	ZZX	–	–	2RS	3.70
	225	49	3	184	153	2 900	–	2 000	3 500	6321	ZZX	–	–	2RS	8.05

Remark) Standard cage types used for the above bearings are described earlier in this section.

Single-row deep groove ball bearings

d 110 – (160) mm

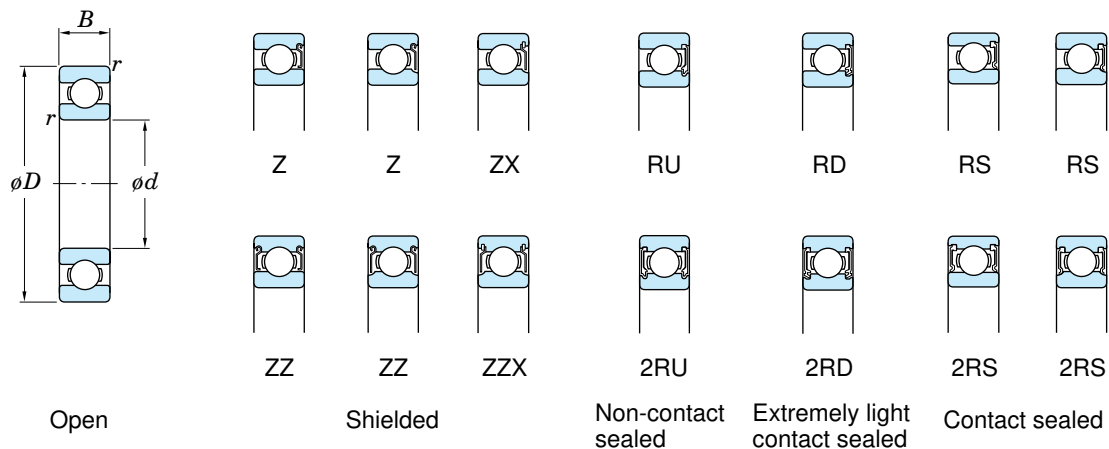

Boundary dimensions (mm)				Basic load ratings (kN)		Limiting speeds (min ⁻¹)				Bearing No.					(Refer.) Mass Open type (kg)
d	D	B	$r_{min.}$	C_r	C_{0r}	Grease lub.		Oil lub.	Open	Shielded ZZ	Sealed 2RU	2RD	2RS		
						$\left\{ \begin{array}{l} \text{Open} \\ Z, ZZ \\ RU, 2RU \end{array} \right\}$	(RD, 2RD)	(RS, 2RS)						$\left\{ \begin{array}{l} \text{Open} \\ Z \end{array} \right\}$	
110	140	16	1	28.1	30.7	4 300	–	–	5 100	6822	ZZ	–	–	–	0.606
	150	20	1.1	47.9	47.8	4 100	–	–	4 900	6922	ZZ	–	–	–	1.04
	170	19	1	57.5	56.7	3 800	–	–	4 500	16022	–	–	–	–	1.46
	170	28	2	82.0	73.0	3 800	–	2 200	4 500	6022	ZZX	–	–	2RS	1.96
	200	38	2.1	144	117	3 100	–	2 000	3 700	6222	ZZX	–	–	2RS	4.36
	240	50	3	205	180	2 700	–	1 900	3 200	6322	ZZX	–	–	2RS	9.54
120	150	16	1	29.0	33.0	4 000	–	–	4 700	6824	ZZ	–	–	–	0.655
	165	22	1.1	57.2	56.9	3 800	–	–	4 400	6924	ZZ	–	–	–	1.41
	180	19	1	63.2	63.3	3 600	–	–	4 200	16024	–	–	–	–	1.80
	180	28	2	85.0	79.3	3 600	–	2 100	4 200	6024	ZZX	–	–	2RS	2.07
	215	40	2.1	155	131	2 900	–	1 900	3 400	6224	ZZX	–	–	2RS	5.15
	260	55	3	207	185	2 500	–	–	3 000	6324	ZZX	–	–	–	12.5
130	165	18	1.1	36.9	41.2	3 600	–	–	4 300	6826	–	–	–	–	0.939
	180	24	1.5	69.6	70.0	3 400	–	–	4 100	6926	–	–	–	–	1.86
	200	22	1.1	71.3	74.8	3 000	–	–	3 600	16026	–	–	–	–	2.69
	200	33	2	106	101	3 200	–	1 900	3 800	6026	ZZX	–	–	2RS	3.16
	230	40	3	167	146	2 700	–	1 800	3 200	6226	ZZX	–	–	2RS	5.82
	280	58	4	229	214	2 300	–	–	2 700	6326	ZZX	–	–	–	15.1
140	175	18	1.1	38.2	44.4	3 400	–	–	4 000	6828	–	–	–	–	1.00
	190	24	1.5	71.3	74.8	3 200	–	–	3 800	6928	–	–	–	–	1.98
	210	22	1.1	65.8	71.1	2 900	–	–	3 400	16028	–	–	–	–	2.86
	210	33	2	110	109	3 000	–	1 800	3 600	6028	ZZX	–	–	2RS	3.55
	250	42	3	166	150	2 400	–	1 600	2 900	6228	ZZX	–	–	2RS	7.45
	300	62	4	253	246	2 100	–	–	2 500	6328	ZZX	–	–	–	19.4
150	190	20	1.1	47.8	54.9	3 100	–	–	3 700	6830	–	–	–	–	1.40
	210	28	2	93.4	94.3	2 900	–	–	3 400	6930	–	–	–	–	3.05
	225	24	1.1	91.2	99.3	2 700	–	–	3 100	16030	–	–	–	–	3.58
	225	35	2.1	125	126	2 800	–	1 600	3 300	6030	ZZX	–	–	2RS	4.22
	270	45	3	176	168	2 200	–	–	2 700	6230	ZZX	–	–	–	9.41
	320	65	4	275	284	1 900	–	–	2 300	6330	–	–	–	–	26.2
160	200	20	1.1	48.4	56.9	2 900	–	–	3 400	6832	–	–	–	–	1.45
	220	28	2	96.1	101	2 700	–	–	3 200	6932	–	–	–	–	3.20
	240	25	1.5	98.8	108	2 600	–	–	3 100	16032	–	–	–	–	4.25

Remark) Standard cage types used for the above bearings are described earlier in this section.

d (160) – 200 mm

Boundary dimensions (mm)				Basic load ratings (kN)		Limiting speeds (min ⁻¹)				Bearing No.					(Refer.) Mass
<i>d</i>	<i>D</i>	<i>B</i>	<i>r</i> min.	<i>C_r</i>	<i>C_{0r}</i>	Grease lub.			Oil lub.	Open	Shielded ZZ	Sealed 2RU	2RD	2RS	Open type (kg)
						$\left[\begin{array}{l} \text{Open} \\ \text{Z, ZZ} \\ \text{RU, 2RU} \end{array} \right]$	(RD, 2RD)	(RS, 2RS)	$\left[\begin{array}{l} \text{Open} \\ \text{Z} \end{array} \right]$						
160	240	38	2.1	136	135	2 600	–	1 500	3 000	6032	ZZX	–	–	2RS	5.22
	290	48	3	185	186	2 100	–	–	2 500	6232	ZZX	–	–	–	14.3
	340	68	4	278	286	1 800	–	–	2 200	6332	–	–	–	–	29.0
170	215	22	1.1	59.8	70.5	2 700	–	–	3 200	6834	–	–	–	–	1.90
	230	28	2	98.8	108	2 600	–	–	3 100	6934	–	–	–	–	3.35
	260	28	1.5	114	127	2 300	–	–	2 700	16034	–	–	–	–	5.75
	260	42	2.1	161	161	2 400	–	–	2 800	6034	ZZX	–	–	–	6.80
	310	52	4	212	223	1 900	–	–	2 300	6234	ZZX	–	–	–	17.5
	360	72	4	326	355	1 700	–	–	2 000	6334	–	–	–	–	38.6
	260	42	2.1	161	161	2 400	–	–	2 800	6034	ZZX	–	–	–	6.80
180	225	22	1.1	60.7	73.1	2 600	–	–	3 000	6836	–	–	–	–	2.00
	250	33	2	123	129	2 400	–	–	2 800	6936	–	–	–	–	4.90
	280	31	2	135	148	2 100	–	–	2 500	16036	–	–	–	–	7.55
	280	46	2.1	182	194	2 200	–	–	2 600	6036	ZZX	–	–	–	10.3
	320	52	4	227	241	1 800	–	–	2 200	6236	ZZX	–	–	–	18.3
	380	75	4	354	407	1 600	–	–	1 900	6336	–	–	–	–	44.7
	280	46	2.1	182	194	2 200	–	–	2 600	6036	ZZX	–	–	–	10.3
190	240	24	1.5	73.1	88.1	2 400	–	–	2 800	6838	–	–	–	–	2.60
	260	33	2	126	138	2 300	–	–	2 700	6938	–	–	–	–	5.20
	290	31	2	139	158	2 000	–	–	2 400	16038	–	–	–	–	7.85
	290	46	2.1	188	201	2 100	–	–	2 500	6038	ZZX	–	–	–	10.8
	340	55	4	255	281	1 700	–	–	2 000	6238	–	–	–	–	23.0
	400	78	5	355	415	1 500	–	–	1 800	6338	–	–	–	–	51.5
	290	46	2.1	188	201	2 100	–	–	2 500	6038	ZZX	–	–	–	10.8
200	250	24	1.5	78.0	93.6	2 300	–	–	2 700	6840	–	–	–	–	2.70
	280	38	2.1	157	168	2 100	–	–	2 500	6940	–	–	–	–	7.30
	310	34	2	161	180	1 900	–	–	2 300	16040	–	–	–	–	10.1
	310	51	2.1	217	243	1 900	–	–	2 300	6040	ZZX	–	–	–	14.0
	360	58	4	269	311	1 600	–	–	1 900	6240	ZZX	–	–	–	28.2
	420	80	5	411	506	1 300	–	–	1 600	6340	–	–	–	–	58.0
	310	51	2.1	217	243	1 900	–	–	2 300	6040	ZZX	–	–	–	14.0

Remark) Standard cage types used for the above bearings are described earlier in this section.

Single-row deep groove ball bearings

snap ring groove type

locating snap ring type

d 10 – 35 mm

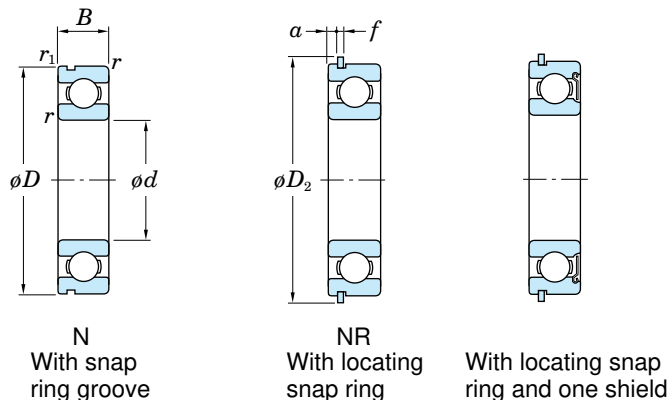

Boundary dimensions (mm)					Basic load ratings (kN)		Limiting speeds (min ⁻¹)		Bearing No.		Dimensions of locating snap ring (mm)			(Refer.) Mass (kg)
d	D	B	r min.	r_1 min.	C_r	C_{or}	Grease lub.	Oil lub.	With snap ring groove	With locating snap ring	D_2 max.	a max.	f ± 0.05	(kg)
10	30	9	0.6	0.3	5.10	2.40	24 000	29 000	6200N	6200NR	34.7	2.06	1.07	0.032
	35	11	0.6	0.5	8.10	3.45	22 000	27 000	6300N	6300NR	39.7	2.06	1.07	0.053
12	32	10	0.6	0.3	6.80	3.05	22 000	27 000	6201N	6201NR	36.7	2.06	1.07	0.037
	37	12	1	0.5	9.70	4.20	20 000	25 000	6301N	6301NR	41.3	2.06	1.07	0.060
15	35	11	0.6	0.5	7.65	3.75	20 000	24 000	6202N	6202NR	39.7	2.06	1.07	0.045
	42	13	1	0.5	11.4	5.45	17 000	20 000	6302N	6302NR	46.3	2.06	1.07	0.082
17	40	12	0.6	0.5	9.55	4.80	17 000	21 000	6203N	6203NR	44.6	2.06	1.07	0.065
	47	14	1	0.5	13.6	6.65	15 000	18 000	6303N	6303NR	52.7	2.46	1.07	0.115
20	42	12	0.6	0.5	9.40	5.05	17 000	21 000	6004N	6004NR	46.3	2.06	1.07	0.069
	47	14	1	0.5	12.8	6.65	15 000	17 000	6204N	6204NR	52.7	2.46	1.07	0.106
	52	15	1.1	0.5	15.9	7.85	14 000	17 000	6304N	6304NR	57.9	2.46	1.07	0.144
22	44	12	0.6	0.5	9.40	5.15	17 000	20 000	60/22N	60/22NR	48.3	2.06	1.07	0.073
	50	14	1	0.5	12.8	6.65	15 000	17 000	62/22N	62/22NR	55.7	2.46	1.07	0.118
	56	16	1.1	0.5	18.5	9.40	13 000	15 000	63/22N	63/22NR	61.7	2.46	1.07	0.201
25	47	12	0.6	0.5	10.1	5.85	15 000	18 000	6005N	6005NR	52.7	2.06	1.07	0.080
	52	15	1	0.5	14.0	7.85	13 000	15 000	6205N	6205NR	57.9	2.46	1.07	0.128
	62	17	1.1	0.5	20.6	11.3	11 000	13 000	6305N	6305NR	67.7	3.28	1.65	0.232
28	52	12	0.6	0.5	12.4	7.40	14 000	16 000	60/28N	60/28NR	57.9	2.06	1.07	0.097
	58	16	1	0.5	17.9	9.75	12 000	14 000	62/28N	62/28NR	63.7	2.46	1.07	0.173
	68	18	1.1	0.5	23.5	13.1	10 000	12 000	63/28N	63/28NR	74.6	3.28	1.65	0.328
30	55	13	1	0.5	13.2	8.25	13 000	15 000	6006N	6006NR	60.7	2.08	1.07	0.116
	62	16	1	0.5	19.5	11.3	11 000	13 000	6206N	6206NR	67.7	3.28	1.65	0.199
	72	19	1.1	0.5	26.7	15.0	9 600	12 000	6306N	6306NR	78.6	3.28	1.65	0.346
32	58	13	1	0.5	15.0	9.15	12 000	14 000	60/32N	60/32NR	63.7	2.08	1.07	0.127
	65	17	1	0.5	23.5	13.1	10 000	12 000	62/32N	62/32NR	70.7	3.28	1.65	0.228
	75	20	1.1	0.5	30.1	16.2	9 300	11 000	63/32N	63/32NR	81.6	3.28	1.65	0.437
35	62	14	1	0.5	15.9	10.3	11 000	13 000	6007N	6007NR	67.7	2.08	1.65	0.155
	72	17	1.1	0.5	25.7	15.4	9 200	11 000	6207N	6207NR	78.6	3.28	1.65	0.288
	80	21	1.5	0.5	33.4	19.3	8 500	10 000	6307N	6307NR	86.6	3.28	1.65	0.457

Remark) Standard cage types used for the above bearings are described earlier in this section.

d 40 – 130 mm

Boundary dimensions (mm)					Basic load ratings (kN)		Limiting speeds (min ⁻¹)		Bearing No.		Dimensions of locating snap ring (mm)			(Refer.) Mass (kg)
<i>d</i>	<i>D</i>	<i>B</i>	<i>r</i> min.	<i>r</i> ₁ min.	<i>C</i> _r	<i>C</i> _{0r}	Grease lub.	Oil lub.	With snap ring groove	With locating snap ring	<i>D</i> ₂ max.	<i>a</i> max.	<i>f</i> ±0.05	
40	68	15	1	0.5	16.7	11.5	10 000	12 000	6008N	6008NR	74.6	2.49	1.65	0.192
	80	18	1.1	0.5	29.1	17.8	8 300	10 000	6208N	6208NR	86.6	3.28	1.65	0.366
	90	23	1.5	0.5	40.7	24.0	7 700	9 200	6308N	6308NR	96.5	3.28	2.41	0.633
45	75	16	1	0.5	21.0	15.1	9 200	11 000	6009N	6009NR	81.6	2.49	1.65	0.245
	85	19	1.1	0.5	32.7	20.3	7 700	9 200	6209N	6209NR	91.6	3.28	1.65	0.407
	100	25	1.5	0.5	48.9	29.5	6 800	8 100	6309N	6309NR	106.5	3.28	2.41	0.833
50	80	16	1	0.5	21.8	16.6	8 400	9 900	6010N	6010NR	86.6	2.49	1.65	0.261
	90	20	1.1	0.5	35.1	23.3	7 100	8 500	6210N	6210NR	96.5	3.28	2.41	0.463
	110	27	2	0.5	62.0	38.3	6 100	7 300	6310N	6310NR	116.6	3.28	2.41	1.07
55	90	18	1.1	0.5	28.3	21.2	7 600	8 900	6011N	6011NR	96.5	2.87	2.41	0.385
	100	21	1.5	0.5	43.4	29.4	6 300	7 600	6211N	6211NR	106.5	3.28	2.41	0.607
	120	29	2	0.5	71.6	45.0	5 600	6 700	6311N	6311NR	129.7	4.06	2.77	1.37
60	95	18	1.1	0.5	29.4	23.2	7 100	8 400	6012N	6012NR	101.6	2.87	2.41	0.415
	110	22	1.5	0.5	52.4	36.2	5 700	6 900	6212N	6212NR	116.6	3.28	2.41	0.783
	130	31	2.1	0.5	81.9	52.2	5 200	6 200	6312N	6312NR	139.7	4.06	2.77	1.70
65	100	18	1.1	0.5	30.5	25.2	6 600	7 800	6013N	6013NR	106.5	2.87	2.41	0.435
	120	23	1.5	0.5	57.2	40.1	5 400	6 400	6213N	6213NR	129.7	4.06	2.77	0.990
	140	33	2.1	0.5	92.7	59.9	4 800	5 800	6313N	6313NR	149.7	4.9	2.77	2.08
70	110	20	1.1	0.5	38.1	30.9	6 100	7 200	6014N	6014NR	116.6	2.87	2.41	0.602
	125	24	1.5	0.5	62.2	44.1	5 100	6 100	6214N	6214NR	134.7	4.06	2.77	1.07
	150	35	2.1	0.5	104	68.2	4 500	5 400	6314N	6314NR	159.7	4.9	2.77	2.52
75	115	20	1.1	0.5	39.6	33.5	5 700	6 800	6015N	6015NR	121.6	2.87	2.41	0.638
	130	25	1.5	0.5	67.4	48.3	4 800	5 800	6215N	6215NR	139.7	4.06	2.77	1.18
	160	37	2.1	0.5	113	77.2	4 200	5 000	6315N	6315NR	169.7	4.9	2.77	3.02
80	125	22	1.1	0.5	47.6	39.8	5 300	6 300	6016N	6016NR	134.7	2.87	2.77	0.850
	140	26	2	0.5	72.7	53.0	4 500	5 400	6216N	6216NR	149.7	4.9	2.77	1.40
	170	39	2.1	0.5	123	86.7	3 900	4 700	6316N	6316NR	182.9	5.69	3.05	3.59
85	130	22	1.1	0.5	49.5	43.1	5 000	5 900	6017N	6017NR	139.7	2.87	2.77	0.890
	150	28	2	0.5	84.0	61.9	4 200	5 000	6217N	6217NR	159.7	4.9	2.77	1.79
	180	41	3	0.5	133	96.8	3 700	4 400	6317N	6317NR	192.9	5.69	3.05	4.23
90	140	24	1.5	0.5	58.2	49.7	4 700	5 600	6018N	6018NR	149.7	3.71	2.77	1.16
	160	30	2	0.5	96.1	71.5	3 900	4 700	6218N	6218NR	169.7	4.9	2.77	2.15
	190	43	3	0.5	143	107	3 500	4 200	6318N	6318NR	202.9	5.69	3.05	4.91
95	145	24	1.5	0.5	60.4	53.9	4 400	5 200	6019N	6019NR	154.7	3.71	2.77	1.21
	170	32	2.1	0.5	109	81.9	3 700	4 400	6219N	6219NR	182.9	5.69	3.05	2.62
	200	45	3	0.5	153	119	3 300	4 000	6319N	6319NR	212.9	5.69	3.05	5.67
100	150	24	1.5	0.5	60.2	54.2	4 300	5 100	6020N	6020NR	159.7	3.71	2.77	1.25
	180	34	2.1	0.5	122	93.1	3 500	4 200	6220N	6220NR	192.9	5.69	3.05	3.14
105	160	26	2	0.5	72.3	65.8	4 000	4 700	6021N	6021NR	169.7	3.71	2.77	1.59
	190	36	2.1	0.5	133	105	3 300	3 900	6221N	6221NR	202.9	5.69	3.05	3.70
110	170	28	2	0.5	82.0	73.0	3 800	4 500	6022N	6022NR	182.9	3.71	3.05	1.96
	200	38	2.1	0.5	144	117	3 100	3 700	6222N	6222NR	212.9	5.69	3.05	4.36
120	180	28	2	0.5	85.0	79.3	3 600	4 200	6024N	6024NR	192.9	3.71	3.05	2.07
130	200	33	2	0.5	106	101	3 200	3 800	6026N	6026NR	212.9	5.69	3.05	3.16

Remark) Standard cage types used for the above bearings are described earlier in this section.

Extra-small ball bearings, miniature ball bearings

d 3 – 9 mm

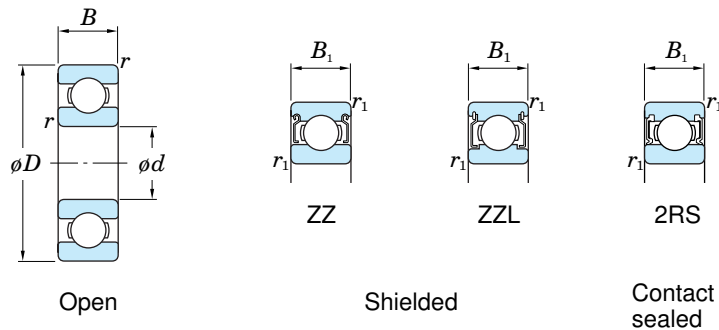

d	Boundary dimensions (mm)					Basic load ratings (kN)		Limiting speeds (min ⁻¹)			Bearing No.			(Refer.) Mass (g)
	D	B	B_1	r min.	r_1 min.	C_r	C_{0r}	Grease lub.	Oil lub.	Open	Shielded ZZ, ZZL	Sealed 2RS		
								[Open ZZ, ZZL]	(2RS)	[Open Z, ZL]				
3	8	3	4	0.15	0.15	0.55	0.17	64 000	–	76 000	693	W693 ZZ	–	0.6
	10	4	4	0.15	0.15	0.64	0.23	52 000	44 000	63 000	623	623 ZZ	623 2RS	1.6
4	11	4	4	0.15	0.15	0.96	0.35	54 000	44 000	65 000	694	694 ZZ	694 2RS	1.8
	12	4	4	0.2	0.2	0.97	0.36	53 000	–	63 000	604	604 ZZ	–	2.1
	13	5	5	0.2	0.2	1.30	0.49	44 000	39 000	54 000	624	624 ZZ	624 2RS	2.9
	16	5	5	0.3	0.3	1.75	0.67	40 000	–	49 000	634	634 ZZ	–	5.3
5	8	2	2.5	0.08	0.05	0.26	0.12	59 000	–	70 000	ML5008	WML5008 ZZ	–	0.3
	9	2.5	3	0.1	0.08	0.47	0.19	56 000	–	67 000	ML5009	WML5009 ZZ	–	0.5
	10	3	4	0.1	0.1	0.50	0.21	55 000	–	65 000	ML5010	WML5010 ZZ	–	0.9
	11	3	5	0.15	0.15	0.97	0.36	53 000	–	63 000	685	W685 ZZ	–	1.0
	13	4	4	0.2	0.2	1.10	0.43	50 000	42 000	60 000	695	695 ZZ	695 2RS	2.2
	16	5	5	0.3	0.3	1.75	0.67	40 000	33 000	49 000	625	625 ZZ	625 2RS	5.0
6	19	6	6	0.3	0.3	2.60	1.05	35 000	27 000	43 000	635	635 ZZ	635 2RS	8.5
	13	3.5	5	0.15	0.15	1.10	0.44	48 000	36 000	57 000	686	W686 ZZ	W686 2RS	1.8
	15	5	5	0.2	0.2	1.75	0.67	45 000	32 000	54 000	696	696 ZZ	696 2RS	3.9
	17	6	6	0.3	0.3	1.95	0.74	43 000	–	51 000	606	606 ZZ	–	5.8
7	19	6	6	0.3	0.3	2.60	1.05	35 000	27 000	43 000	626	626 ZZ	626 2RS	8.1
	14	3.5	5	0.15	0.15	1.15	0.51	45 000	–	54 000	687	W687 ZZ	–	2.0
	19	6	6	0.3	0.3	2.60	1.05	40 000	27 000	47 000	607	607 ZZ	607 2RS	7.6
8	22	7	7	0.3	0.3	3.30	1.35	31 000	23 000	37 000	627	627 ZZ	627 2RS	13
	16	4	5	0.2	0.2	1.60	0.71	42 000	28 000	50 000	688	W688 ZZ	W688 2RS	3.2
	19	6	6	0.3	0.3	2.25	0.91	39 000	27 000	46 000	698	698 ZZ	698 2RS	7.2
	22	7	7	0.3	0.3	3.30	1.35	34 000	23 000	41 000	608	608 ZZ	608 2RS	12
	24	8	8	0.3	0.3	3.35	1.40	28 000	22 000	35 000	628	628 ZZ	628 2RS	18
	28	9	9	0.3	0.3	4.55	1.95	26 000	–	32 000	638	638 ZZ	–	29
9	17	4	5	0.2	0.2	1.35	0.66	39 000	–	46 000	689	W689 ZZ	–	3.5
	20	6	6	0.3	0.3	2.45	1.05	35 000	25 000	42 000	699	699 ZZ	699 2RS	7.5
	24	7	7	0.3	0.3	3.35	1.40	33 000	22 000	40 000	609	609 ZZ	609 2RS	15
	26	8	8	0.6	0.6	4.55	1.95	27 000	19 000	33 000	629	629 ZZ	629 2RS	20

Double-row deep groove ball bearings

d 15 – 75 mm

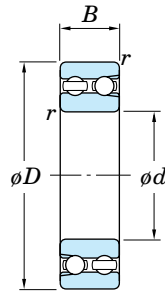

Boundary dimensions (mm)				Basic load ratings (kN)		Limiting speeds (min ⁻¹)		Bearing No.	(Refer.) Mass (kg)
d	D	B	$r_{\text{min.}}$	C_r	C_{0r}	Grease lub.	Oil lub.		
15	35	14	0.6	9.75	9.00	12 000	16 000	4202	0.071
17	40	16	0.6	11.7	10.4	11 000	14 000	4203	0.106
20	47	18	1	16.4	16.0	9 000	12 000	4204	0.165
	52	21	1.1	19.5	17.0	8 300	11 000	4304	0.227
25	52	18	1	16.3	16.9	7 500	9 900	4205	0.189
	62	24	1.1	26.3	25.7	6 700	9 000	4305	0.365
30	62	20	1	22.0	24.7	6 400	8 500	4206	0.298
	72	27	1.1	35.5	35.9	5 700	7 600	4306	0.542
35	72	23	1.1	26.4	30.7	5 600	7 400	4207	0.460
	80	31	1.5	40.6	41.8	5 200	7 000	4307	0.752
40	80	23	1.1	33.7	42.4	4 700	6 300	4208	0.558
	90	33	1.5	46.0	48.8	4 600	6 100	4308	1.01
45	85	23	1.1	31.9	43.9	4 600	6 100	4209	0.605
	100	36	1.5	57.6	62.4	4 100	5 500	4309	1.35
50	90	23	1.1	31.4	44.6	4 200	5 600	4210	0.651
	110	40	2	70.4	77.7	3 700	5 000	4310	1.80
55	100	25	1.5	37.2	54.1	3 800	5 000	4211	0.882
	120	43	2	84.2	94.4	3 400	4 600	4311	2.29
60	110	28	1.5	47.9	67.6	3 500	4 700	4212	1.20
	130	46	2.1	99.2	113	3 100	4 200	4312	2.87
65	120	31	1.5	54.7	78.5	3 200	4 300	4213	1.59
	140	48	2.1	107	124	2 900	3 900	4313	3.46
70	125	31	1.5	62.1	89.8	3 100	4 100	4214	1.68
	150	51	2.1	115	136	2 700	3 600	4314	4.21
75	130	31	1.5	61.6	90.7	2 900	3 900	4215	1.77
	160	55	2.1	132	158	2 500	3 400	4315	5.15

KOYO



Angular contact ball bearings

Angular contact ball bearings are suitable for applications which require high accuracy and good high-speed performance. This type of bearing is designed to carry a combined load.

■ **Single-row angular contact ball bearings and matched pair angular contact ball bearings**

- The standard contact angles are 15°, 30° and 40°.

They are identified, respectively, by the supplementary codes "C", "A" (omitted) and "B". Bearing with a smaller contact angle are more suitable for applications involving high-speed rotation. Those with a larger contact angle feature superior axial load resistance.

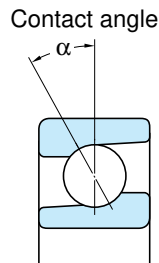

- Angular contact ball bearings are often preloaded to enhance their rigidity and rotating performance. For high-precision matched pair angular contact ball bearings of class 5 or higher, which are used in machine tools and other precision equipment, the standard preload is specified in three levels: light (L), medium (M) and heavy (H).
- When this type of bearing is loaded radially, an axial component of force is produced. In this case, two bearings are used together facing one another, or two or more bearings are matched and used.
- Tables 1 and 2 list the different types of single-row and matched pair/stack angular contact ball bearings and describe their characteristics.

■ **Double-row angular contact ball bearings**
Consist of two single-row angular contact ball bearings matched back-to-back, with inner and outer rings integrated.

Table 3 shows major types and their characteristics.

Single-row angular contact ball bearings

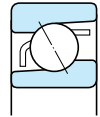

Bore diameter **10 – 200 mm**

Double-row angular contact ball bearings

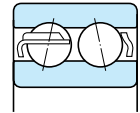

Bore diameter **15 – 100 mm**

Angular contact ball bearings

Table 1 Single-row angular contact ball bearings

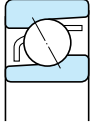
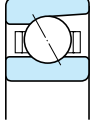
 (with pressed cage)	<ul style="list-style-type: none"> • Single-row angular contact ball bearings accommodate radial load and axial load in one direction. • Bearings with a machined cage are suitable for high-speed applications.
 (with machined cage)	

Reference G-shaped bearing

"G-shaped" bearings have a stand-out between the inner ring and outer ring on both sides that are equal in size. This arrangement is called "flush ground processing". These bearings can be matched in a variety of ways.

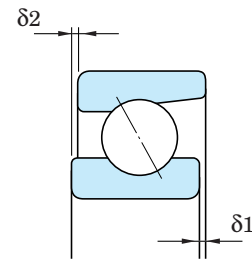
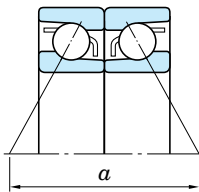
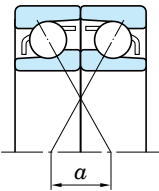
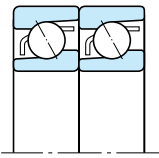

Table 2 Matched pair and stack angular contact ball bearings

Back-to-back arrangement (DB)		<ul style="list-style-type: none"> • Carries radial load and axial load in both directions. • Suitable for applications involving moment loading because the distance between the load centers (a) is long. • As for the preloaded type, the clearance is pre-adjusted so that bearings will be preloaded the proper amount when the inner ring is fixed with a nut.
Face-to-face arrangement (DF)		<ul style="list-style-type: none"> • Carries radial load and axial load in both directions. • Has a smaller moment load accommodating capacity than the back-to-back arrangement, because the distance between the load centers (a) is shorter. • As for the preloaded type, the clearance is pre-adjusted so that bearings will be preloaded the proper amount when the outer rings are pressed together.
Tandem arrangement (DT)		<ul style="list-style-type: none"> • Carries radial load and axial load in one direction. • Suitable for applications which involve a high degree of axial loading.

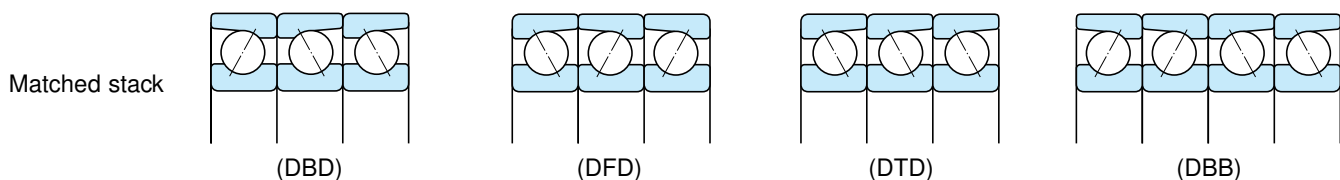
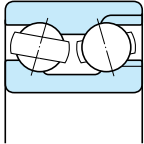
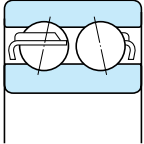
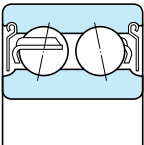
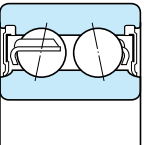

Table 3 Double-row angular contact ball bearings

 (with filling slot) 32, 33	 (without filling slot) 52, 53	<ul style="list-style-type: none"> Accommodates radial load and axial load in both directions. Also able to accommodate moment load. The 32 and 33 series are provided with a filling slot, while the 52 and 53 series are not. 32 and 33 series : contact angle 32° 52 and 53 series : contact angle 24°
 Shielded 52...ZZ, 53...ZZ	 Sealed 52...2RS, 53...2RS	

Boundary dimensions	The dimensions of standard series are as specified in JIS B 1512.																																			
Tolerances	<ul style="list-style-type: none"> As specified in JIS B 1514. Koyo has established "special tolerances" for bore diameter and outside diameter, as listed in the table to the right, to make it easy to produce high precision matched stack bearings. Bearings which are produced based on these tolerances are identified by the supplementary code "K5." 	<p style="text-align: right;">Special tolerances (K5) Unit μm</p> <table border="1"> <thead> <tr> <th colspan="2" rowspan="2">Nominal bore diameter d (mm)</th> <th colspan="4">Single plane mean bore diameter (Δd_{mp}) or single plane mean outside diameter deviation (ΔD_{mp})</th> </tr> <tr> <th colspan="2">Class 5</th> <th colspan="2">Class 4</th> </tr> <tr> <th>over</th> <th>up to</th> <th>upper</th> <th>lower</th> <th>upper</th> <th>lower</th> </tr> </thead> <tbody> <tr> <td>–</td> <td>50</td> <td>–1</td> <td>–4</td> <td>–1</td> <td>–3</td> </tr> <tr> <td>50</td> <td>80</td> <td>–1</td> <td>–5</td> <td>–1</td> <td>–4</td> </tr> <tr> <td>80</td> <td>120</td> <td>–1</td> <td>–5</td> <td>–1</td> <td>–4</td> </tr> </tbody> </table>	Nominal bore diameter d (mm)		Single plane mean bore diameter (Δd_{mp}) or single plane mean outside diameter deviation (ΔD_{mp})				Class 5		Class 4		over	up to	upper	lower	upper	lower	–	50	–1	–4	–1	–3	50	80	–1	–5	–1	–4	80	120	–1	–5	–1	–4
Nominal bore diameter d (mm)		Single plane mean bore diameter (Δd_{mp}) or single plane mean outside diameter deviation (ΔD_{mp})																																		
		Class 5		Class 4																																
over	up to	upper	lower	upper	lower																															
–	50	–1	–4	–1	–3																															
50	80	–1	–5	–1	–4																															
80	120	–1	–5	–1	–4																															
Internal clearance	<ul style="list-style-type: none"> Matched pair bearing axial internal clearance (refer to Table 2-3 on p. A 12.) Double-row bearing radial internal clearance (refer to Table 2-4 on p. A 13.) 																																			
Recommended fits	<ul style="list-style-type: none"> Classes 5 and 4 bearings as listed in the table below. <table border="1" style="margin-left: auto; margin-right: auto;"> <thead> <tr> <th colspan="2" rowspan="2">Fit</th> <th>Class 5</th> <th>Class 4</th> </tr> <tr> <th colspan="2">Tolerance class</th> </tr> </thead> <tbody> <tr> <td rowspan="2">With shaft</td> <td>Inner ring rotation</td> <td>js 5</td> <td>js 4</td> </tr> <tr> <td>Outer ring rotation</td> <td>h 5</td> <td>h 4</td> </tr> <tr> <td rowspan="3">With housing</td> <td>Fixed side</td> <td>JS 6</td> <td>JS 5</td> </tr> <tr> <td>Free side</td> <td>H 6</td> <td>H 5</td> </tr> <tr> <td>Outer ring rotation</td> <td>M 5</td> <td>M 4</td> </tr> </tbody> </table>		Fit		Class 5	Class 4	Tolerance class		With shaft	Inner ring rotation	js 5	js 4	Outer ring rotation	h 5	h 4	With housing	Fixed side	JS 6	JS 5	Free side	H 6	H 5	Outer ring rotation	M 5	M 4											
Fit		Class 5			Class 4																															
		Tolerance class																																		
With shaft	Inner ring rotation	js 5	js 4																																	
	Outer ring rotation	h 5	h 4																																	
With housing	Fixed side	JS 6	JS 5																																	
	Free side	H 6	H 5																																	
	Outer ring rotation	M 5	M 4																																	

Equivalent radial load (Double-row angular contact ball bearings)	Dynamic equivalent radial load $P_r = XF_r + YF_a$	<table border="1"> <thead> <tr> <th rowspan="2">Contact angle</th> <th rowspan="2">e</th> <th colspan="2">$F_a / F_r \leq e$</th> <th colspan="2">$F_a / F_r > e$</th> <th rowspan="2">(reference)</th> </tr> <tr> <th>X</th> <th>Y</th> <th>X</th> <th>Y</th> </tr> </thead> <tbody> <tr> <td>24°</td> <td>0.66</td> <td>1</td> <td>0.95</td> <td>0.68</td> <td>1.45</td> <td>52, 53 series</td> </tr> <tr> <td>32°</td> <td>0.86</td> <td>1</td> <td>0.73</td> <td>0.62</td> <td>1.17</td> <td>32, 33 series</td> </tr> </tbody> </table>	Contact angle	e	$F_a / F_r \leq e$		$F_a / F_r > e$		(reference)	X	Y	X	Y	24°	0.66	1	0.95	0.68	1.45	52, 53 series	32°	0.86	1	0.73	0.62	1.17	32, 33 series
	Contact angle	e			$F_a / F_r \leq e$		$F_a / F_r > e$			(reference)																	
			X	Y	X	Y																					
	24°	0.66	1	0.95	0.68	1.45	52, 53 series																				
32°	0.86	1	0.73	0.62	1.17	32, 33 series																					
Static equivalent radial load $P_{0r} = X_0 F_r + Y_0 F_a$	<table border="1"> <thead> <tr> <th>Contact angle</th> <th>X_0</th> <th>Y_0</th> <th>(reference)</th> </tr> </thead> <tbody> <tr> <td>24°</td> <td>1</td> <td>0.78</td> <td>52, 53 series</td> </tr> <tr> <td>32°</td> <td>1</td> <td>0.63</td> <td>32, 33 series</td> </tr> </tbody> </table>	Contact angle	X_0	Y_0	(reference)	24°	1	0.78	52, 53 series	32°	1	0.63	32, 33 series														
Contact angle	X_0	Y_0	(reference)																								
24°	1	0.78	52, 53 series																								
32°	1	0.63	32, 33 series																								

Remark) In angular contact ball bearings, slippage occurs between the balls and raceways under too small a load, causing smearing to develop.
 Matched pair bearings may develop smearing when the ratio of the axial load to the radial load exceeds the value of e ($F_a / F_r > e$), as listed in the specification table.
 Consult Koyo when these bearings are used under the above conditions.

[Reference] Relationship between axial load and axial displacement

Diagrams (1) to (6) illustrate the relationship between axial load and axial displacement.

(1) 7000C (contact angle 15°)

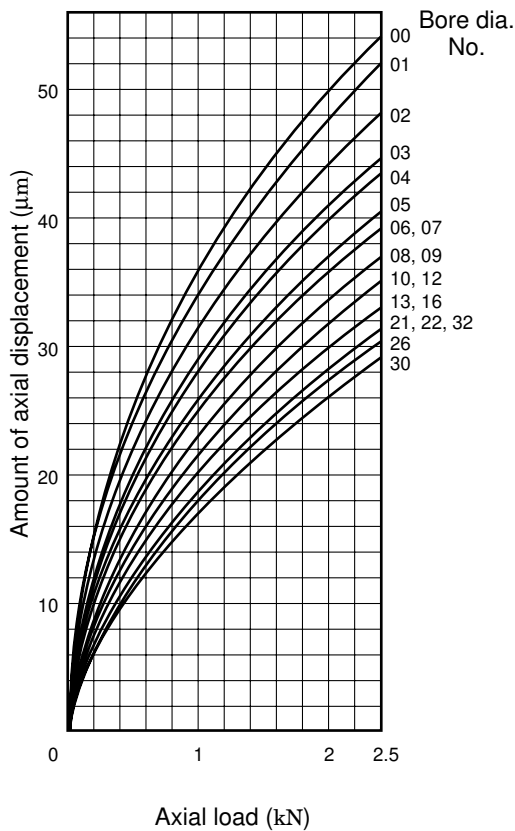

(2) 7200C (contact angle 15°)

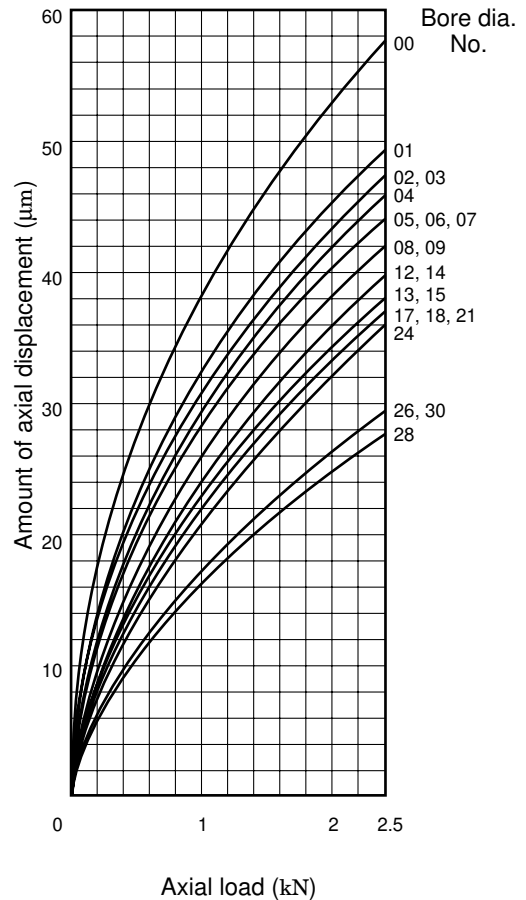

Angular contact ball bearings

(3) 7000 (contact angle 30°)

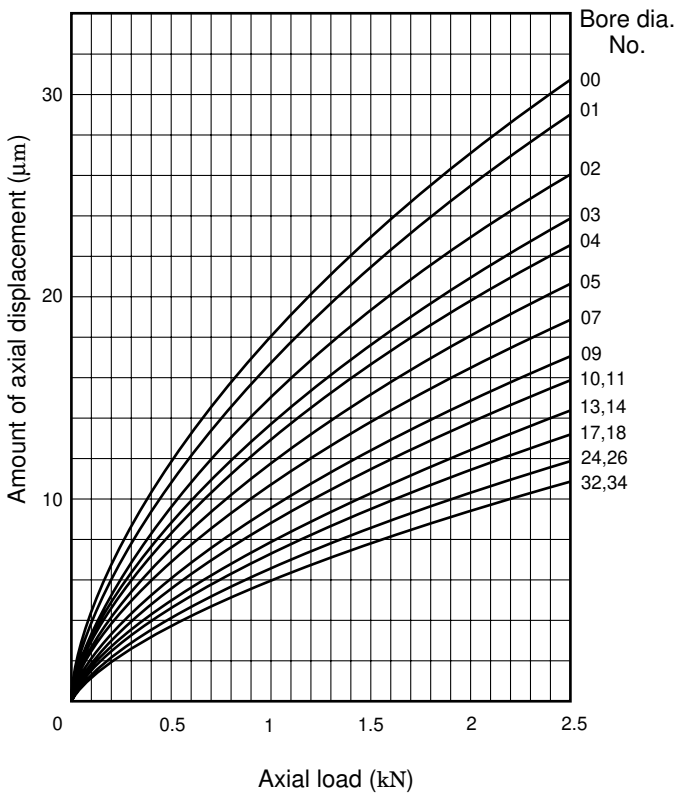

(4) 7200 (contact angle 30°)

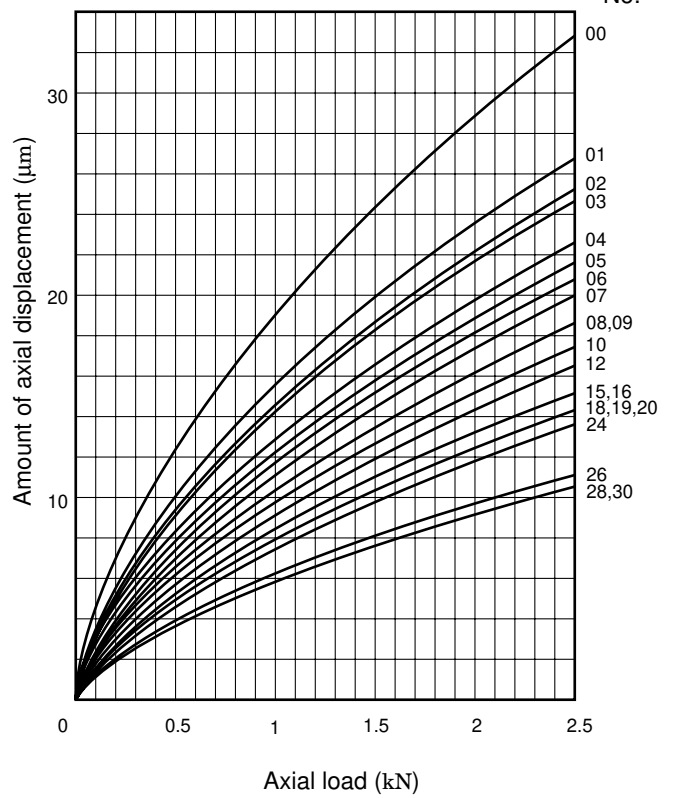

(5) 7000B (contact angle 40°)

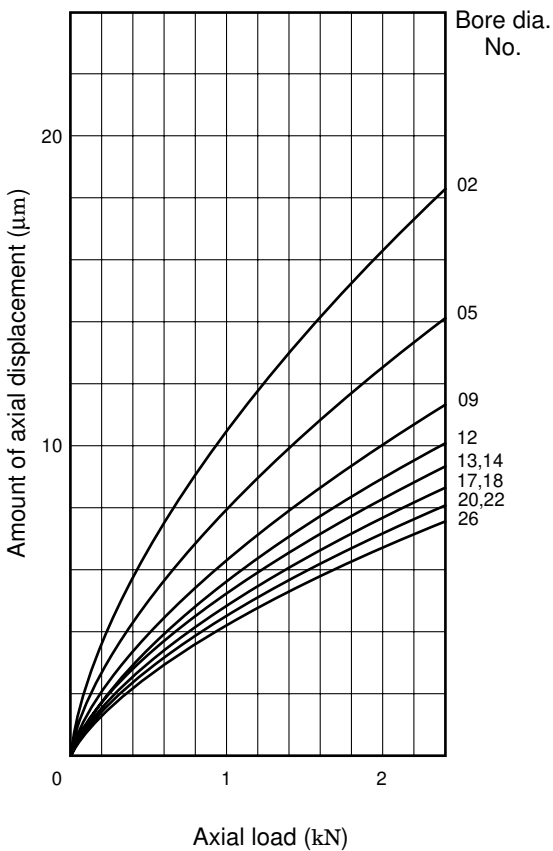

(6) 7200B (contact angle 40°)

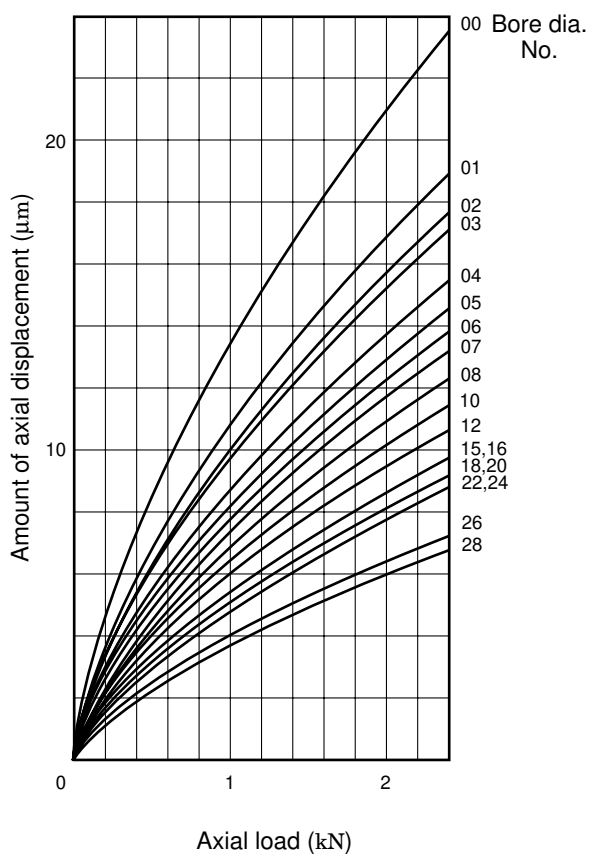



Single-row angular contact ball bearings

d 10 – (25) mm

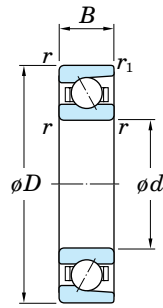

With machined cage

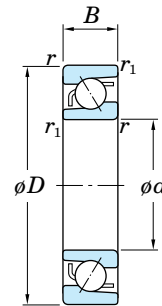

With pressed cage

d	Boundary dimensions (mm)				Basic load ratings (kN)				Limiting speeds ¹⁾ (min ⁻¹)		Bearing No.	(Refer.) Mass (kg)
	D	B	r min.	r_1 min.	With machined cage		With pressed cage		Grease lub.	Oil lub.		
	C_r	C_{0r}	C_r	C_{0r}								
10	26	8	0.3	0.15	5.00	2.35	—	—	34 000	42 000	7000 7200B	0.021
	30	9	0.6	0.3	4.30	2.00	4.95	2.50	22 000	29 000		0.031
12	28	8	0.3	0.15	5.40	2.75	—	—	29 000	37 000	7001 7201	0.024
	32	10	0.6	0.3	7.45	3.65	8.00	4.05	27 000	34 000		7201B
	32	10	0.6	0.3	6.95	3.40	7.40	3.75	20 000	27 000	7201C 7301	
	37	12	1	0.6	10.2	4.60	11.2	5.25	24 000	31 000		0.065
15	32	9	0.3	0.15	6.10	3.45	—	—	26 000	32 000	7002 7202	0.035
	35	11	0.6	0.3	8.10	4.25	8.10	4.25	24 000	29 000		7202B
	35	11	0.6	0.3	7.45	3.95	7.45	3.95	18 000	24 000	7202C 7302	
	42	13	1	0.6	12.5	6.45	13.4	7.20	20 000	25 000		0.088
17	35	10	0.3	0.15	6.75	4.15	—	—	23 000	28 000	7003 7203	0.045
	40	12	0.6	0.3	10.2	5.50	10.2	5.50	21 000	26 000		7203B
	40	12	0.6	0.3	9.35	5.05	9.35	5.05	16 000	21 000	7203C 7303 7303B	
	47	14	1	0.6	14.9	7.90	16.0	8.75	18 000	23 000		0.120
	47	14	1	0.6	13.8	7.30	14.8	8.10	14 000	18 000		0.120
	40	12	0.6	0.3	10.9	5.90	10.9	5.90	29 000	38 000		0.070
20	42	12	0.6	0.3	10.3	6.10	—	—	19 000	24 000	7004 7204	0.079
	47	14	1	0.6	14.5	8.40	15.4	9.15	17 000	22 000		7204B
	47	14	1	0.6	13.3	7.70	14.1	8.40	13 000	17 000	7204C 7304 7304B	
	47	14	1	0.6	15.5	9.00	16.5	9.80	24 000	32 000		0.112
	52	15	1.1	0.6	17.4	9.40	18.7	10.4	17 000	21 000		0.150
	52	15	1.1	0.6	16.2	8.70	17.3	9.65	13 000	17 000		0.150
	52	15	1.1	0.6	18.5	9.95	19.9	11.1	23 000	31 000	7304C 7404	0.150
	72	19	1.1	0.6	35.6	19.1	—	—	9 600	13 000		0.395
72	19	1.1	0.6	33.5	17.9	—	—	8 500	12 000	7404B	0.395	
25	47	12	0.6	0.3	11.3	7.40	—	—	17 000	21 000	7005 7005C	0.091
	47	12	0.6	0.3	12.3	8.00	—	—	23 000	30 000		0.091

Notes 1) Rotation speed limits shown above are applicable to machined cage bearings.

Rotation speed limits of pressed cage bearings should be kept to under 80 % of this value.

For bearings with 15° contact angle, this figure is applied to the high precision bearings ranked higher than class 5, used with machined cage or molded cage.

2) B, C or no indication after the bearing number indicates nominal contact angle of 40°, 15° and 30° respectively.

Remark) Standard cage types used for the above bearings are described earlier in this section.

d (25) – (45) mm

Boundary dimensions (mm)					Basic load ratings (kN)				Limiting speeds ¹⁾ (min ⁻¹)		Bearing ²⁾ No.	(Refer.) Mass (kg)	
<i>d</i>	<i>D</i>	<i>B</i>	<i>r</i> min.	<i>r</i> ₁ min.	With machined cage		With pressed cage		Grease lub.	Oil lub.			
					<i>C_r</i>	<i>C_{0r}</i>	<i>C_r</i>	<i>C_{0r}</i>					
25	52	15	1	0.6	15.3	9.50	16.2	10.3	15 000	19 000	7205	0.135	
	52	15	1	0.6	14.0	8.70	14.7	9.40	12 000	15 000	7205B	0.135	
	52	15	1	0.6	16.6	10.2	17.5	11.1	21 000	28 000	7205C	0.135	
	62	17	1.1	0.6	24.8	14.4	26.4	15.8	14 000	17 000	7305	0.243	
	62	17	1.1	0.6	22.9	13.3	24.4	14.6	10 000	14 000	7305B	0.243	
	62	17	1.1	0.6	26.4	15.3	28.1	16.8	19 000	25 000	7305C	0.243	
	80	21	1.5	1	39.7	23.2	42.6	25.7	8 200	11 000	7405	0.527	
	80	21	1.5	1	36.9	21.5	39.6	23.9	7 300	10 000	7405B	0.527	
	30	55	13	1	0.6	14.5	10.1	—	—	14 000	18 000	7006	0.133
55		13	1	0.6	15.8	11.0	—	—	20 000	26 000	7006C	0.133	
62		16	1	0.6	21.3	13.7	22.5	14.8	13 000	16 000	7206	0.208	
62		16	1	0.6	19.4	12.5	20.5	13.6	9 600	13 000	7206B	0.208	
62		16	1	0.6	23.0	14.7	24.3	16.0	18 000	24 000	7206C	0.208	
72		19	1.1	0.6	30.1	18.9	31.9	20.6	12 000	14 000	7306	0.362	
72		19	1.1	0.6	27.6	17.4	29.3	19.0	8 700	12 000	7306B	0.362	
72		19	1.1	0.6	32.3	20.3	34.2	22.1	16 000	21 000	7306C	0.362	
90		23	1.5	1	47.6	28.4	51.0	31.6	7 300	9 700	7406	0.686	
90		23	1.5	1	44.2	26.4	47.4	29.3	6 500	8 900	7406B	0.686	
35		62	14	1	0.6	17.5	12.6	—	—	12 000	15 000	7007	0.170
		62	14	1	0.6	19.1	13.7	—	—	17 000	22 000	7007C	0.170
	72	17	1.1	0.6	28.1	18.6	29.7	20.2	11 000	14 000	7207	0.295	
	72	17	1.1	0.6	25.6	17.0	27.0	18.5	8 300	11 000	7207B	0.295	
	72	17	1.1	0.6	30.4	20.1	32.1	21.7	15 000	20 000	7207C	0.295	
	80	21	1.5	1	35.4	22.0	39.9	26.4	10 000	13 000	7307	0.475	
	80	21	1.5	1	32.5	20.2	36.6	24.3	7 700	10 000	7307B	0.475	
	80	21	1.5	1	37.9	23.6	42.8	28.3	14 000	19 000	7307C	0.475	
	100	25	1.5	1	60.4	37.0	64.8	41.1	6 500	8 600	7407	0.950	
	100	25	1.5	1	56.2	34.3	60.2	38.1	5 700	7 900	7407B	0.950	
	40	68	15	1	0.6	18.7	14.6	—	—	11 000	14 000	7008	0.210
		68	15	1	0.6	20.5	15.9	—	—	15 000	20 000	7008C	0.210
80		18	1.1	0.6	33.6	23.3	35.3	25.1	10 000	12 000	7208	0.382	
80		18	1.1	0.6	30.6	21.3	32.1	23.0	7 500	10 000	7208B	0.382	
80		18	1.1	0.6	36.4	25.2	38.2	27.1	14 000	18 000	7208C	0.382	
90		23	1.5	1	43.2	27.4	48.8	32.9	9 200	12 000	7308	0.657	
90		23	1.5	1	39.7	25.2	44.8	30.3	6 900	9 200	7308B	0.657	
90		23	1.5	1	46.3	29.4	52.3	35.3	13 000	17 000	7308C	0.657	
110		27	2	1	69.9	43.5	75.0	48.4	5 900	7 900	7408	1.23	
110		27	2	1	64.9	40.4	69.6	44.9	5 200	7 200	7408B	1.23	
45		75	16	1	0.6	22.2	17.7	—	—	10 000	12 000	7009	0.260
		75	16	1	0.6	24.4	19.3	—	—	14 000	18 000	7009C	0.260
	85	19	1.1	0.6	37.7	26.6	39.6	28.6	9 400	12 000	7209	0.430	
	85	19	1.1	0.6	34.3	24.3	36.1	26.1	7 000	9 400	7209B	0.430	
	85	19	1.1	0.6	40.8	28.7	42.9	30.9	13 000	17 000	7209C	0.430	
	100	25	1.5	1	55.1	37.1	58.4	40.4	8 200	10 000	7309	0.875	

Notes 1) Rotation speed limits shown above are applicable to machined cage bearings.

Rotation speed limits of pressed cage bearings should be kept to under 80 % of this value.

For bearings with 15° contact angle, this figure is applied to the high precision bearings ranked higher than class 5, used with machined cage or molded cage.

2) B, C or no indication after the bearing number indicates nominal contact angle of 40°, 15° and 30° respectively.

Remark) Standard cage types used for the above bearings are described earlier in this section.

Single-row angular contact ball bearings

d (45) – (60) mm

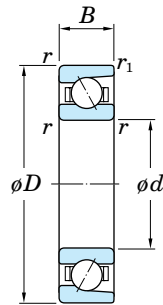

With machined cage

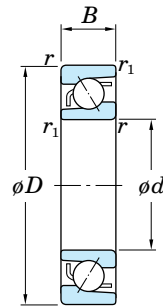

With pressed cage

Boundary dimensions (mm)					Basic load ratings (kN)				Limiting speeds ¹⁾ (min ⁻¹)		Bearing No.	(Refer.) Mass (kg)
d	D	B	r min.	r_1 min.	With machined cage		With pressed cage		Grease lub.	Oil lub.		
					C_r	C_{0r}	C_r	C_{0r}				
45	100	25	1.5	1	50.6	34.1	53.6	37.2	6 200	8 200	7309B	0.875
	100	25	1.5	1	59.2	39.7	62.7	43.4	11 000	15 000	7309C	0.875
	120	29	2	1	84.9	53.8	91.1	59.8	5 400	7 100	7409	1.55
	120	29	2	1	78.9	50.0	84.7	55.5	4 800	6 600	7409B	1.55
50	80	16	1	0.6	23.6	20.1	–	–	9 200	11 000	7010	0.290
	80	16	1	0.6	26.0	21.9	–	–	13 000	17 000	7010C	0.290
	90	20	1.1	0.6	39.4	29.4	41.3	31.5	8 500	11 000	7210	0.485
	90	20	1.1	0.6	35.7	26.7	37.4	28.6	6 400	8 500	7210B	0.485
	90	20	1.1	0.6	42.8	31.8	44.8	34.1	12 000	16 000	7210C	0.485
	110	27	2	1	70.1	48.1	74.3	52.5	7 300	9 100	7310	1.14
	110	27	2	1	64.4	44.3	68.2	48.3	5 500	7 300	7310B	1.14
	110	27	2	1	75.1	51.6	79.6	56.2	10 000	13 000	7310C	1.14
	130	31	2.1	1.1	97.4	65.3	–	–	4 900	6 600	7410	1.92
	130	31	2.1	1.1	90.2	60.4	–	–	4 400	6 000	7410B	1.92
55	90	18	1.1	0.6	31.1	26.3	–	–	8 300	10 000	7011	0.420
	90	18	1.1	0.6	34.1	28.6	–	–	11 000	15 000	7011C	0.420
	100	21	1.5	1	48.7	37.1	51.0	39.8	7 600	9 500	7211	0.635
	100	21	1.5	1	44.1	33.8	46.2	36.2	5 700	7 600	7211B	0.635
	100	21	1.5	1	52.9	40.2	55.4	43.1	11 000	14 000	7211C	0.635
	120	29	2	1	80.9	56.5	85.8	61.7	6 700	8 400	7311	1.45
	120	29	2	1	74.3	52.0	78.7	56.7	5 000	6 700	7311B	1.45
	140	33	2.1	1.1	118	82.4	–	–	4 500	6 000	7411	2.36
	140	33	2.1	1.1	110	76.5	–	–	4 000	5 500	7411B	2.36
60	95	18	1.1	0.6	31.9	28.1	–	–	7 700	9 700	7012	0.450
	95	18	1.1	0.6	35.0	30.6	–	–	11 000	14 000	7012C	0.450
	110	22	1.5	1	58.9	45.7	61.7	49.0	6 900	8 600	7212	0.820
	110	22	1.5	1	53.4	41.6	55.9	44.6	5 100	6 900	7212B	0.820
	110	22	1.5	1	64.0	49.5	67.0	53.0	9 500	13 000	7212C	0.820
	130	31	2.1	1.1	92.5	65.6	98.1	71.6	6 200	7 700	7312	1.81

Notes 1) Rotation speed limits shown above are applicable to machined cage bearings.

Rotation speed limits of pressed cage bearings should be kept to under 80 % of this value.

For bearings with 15° contact angle, this figure is applied to the high precision bearings ranked higher than class 5, used with machined cage or molded cage.

2) B, C or no indication after the bearing number indicates nominal contact angle of 40°, 15° and 30° respectively.

Remark) Standard cage types used for the above bearings are described earlier in this section.

d (60) – (85) mm

<i>d</i>	Boundary dimensions (mm)				Basic load ratings (kN)				Limiting speeds ¹⁾ (min ⁻¹)		Bearing No.	(Refer.) Mass (kg)	
	<i>D</i>	<i>B</i>	<i>r</i> _{min.}	<i>r</i> _{1 min.}	With machined cage		With pressed cage		Grease lub.	Oil lub.			
					<i>C_r</i>	<i>C_{0r}</i>	<i>C_r</i>	<i>C_{0r}</i>					
60	130	31	2.1	1.1	84.9	60.3	90.0	65.8	4 600	6 200	7312B	1.81	
	150	35	2.1	1.1	129	93.6	—	—	4 100	5 500	7412	2.85	
	150	35	2.1	1.1	119	86.7	—	—	3 700	5 100	7412B	2.85	
65	100	18	1.1	0.6	33.7	31.4	—	—	7 200	9 000	7013	0.470	
	100	18	1.1	0.6	37.1	34.3	—	—	10 000	13 000	7013C	0.470	
	120	23	1.5	1	67.3	54.2	70.2	57.8	6 400	8 000	7213	1.02	
	120	23	1.5	1	60.9	49.3	63.6	52.6	4 800	6 400	7213B	1.02	
	120	23	1.5	1	73.1	58.7	76.3	62.6	8 900	12 000	7213C	1.02	
	140	33	2.1	1.1	105	75.3	111	82.2	5 800	7 200	7313	2.22	
	140	33	2.1	1.1	96.1	69.3	102	75.6	4 300	5 800	7313B	2.22	
	160	37	2.1	1.1	139	104	—	—	3 900	5 200	7413	3.41	
	160	37	2.1	1.1	129	96.8	—	—	3 500	4 800	7413B	3.41	
	70	110	20	1.1	0.6	42.7	39.4	—	—	6 600	8 300	7014	0.660
110		20	1.1	0.6	46.9	43.0	—	—	9 200	12 000	7014C	0.660	
125		24	1.5	1	69.8	55.6	76.3	63.5	6 100	7 600	7214	1.12	
125		24	1.5	1	63.2	50.6	69.1	57.8	4 600	6 100	7214B	1.12	
125		24	1.5	1	75.9	60.2	83.0	68.8	8 400	11 000	7214C	1.12	
150		35	2.1	1.1	118	85.8	125	93.6	5 400	6 700	7314	2.70	
150		35	2.1	1.1	108	78.9	114	86.0	4 000	5 400	7314B	2.70	
180		42	3	1.1	149	115	—	—	3 500	4 600	7414	4.99	
180		42	3	1.1	148	119	—	—	3 100	4 300	7414B	4.99	
75		115	20	1.1	0.6	43.6	41.7	—	—	6 300	7 800	7015	0.690
	130	25	1.5	1	79.2	65.2	82.7	69.5	5 800	7 200	7215	1.23	
	130	25	1.5	1	71.7	59.3	74.9	63.3	4 300	5 800	7215B	1.23	
	130	25	1.5	1	86.1	70.6	89.9	75.3	8 000	11 000	7215C	1.23	
	160	37	2.1	1.1	128	97.0	136	106	5 000	6 300	7315	3.15	
	160	37	2.1	1.1	118	89.2	125	97.3	3 800	5 000	7315B	3.15	
	190	45	3	1.1	171	141	—	—	3 300	4 400	7415	5.90	
	190	45	3	1.1	158	131	—	—	2 900	4 000	7415B	5.90	
	80	125	22	1.1	0.6	53.4	50.6	—	—	5 800	7 200	7016	0.930
		140	26	2	1	85.3	71.5	89.0	76.2	5 400	6 700	7216	1.50
140		26	2	1	77.1	65.0	80.5	69.3	4 000	5 400	7216B	1.50	
140		26	2	1	92.8	77.5	96.9	82.7	7 500	9 900	7216C	1.50	
170		39	2.1	1.1	139	109	147	119	4 700	5 900	7316	3.85	
170		39	2.1	1.1	127	100	135	109	3 500	4 700	7316B	3.85	
200		48	3	1.1	193	166	—	—	3 100	4 100	7416	6.00	
200		48	3	1.1	179	154	—	—	2 700	3 800	7416B	6.00	
85		130	22	1.1	0.6	54.6	53.7	—	—	5 500	6 800	7017	0.970
		130	22	1.1	0.6	60.1	58.7	—	—	7 600	10 000	7017C	0.970
	150	28	2	1	98.6	83.6	103	89.2	5 000	6 300	7217	1.87	
	150	28	2	1	89.2	76.0	93.1	81.1	3 800	5 000	7217B	1.87	
	150	28	2	1	107	90.6	112	96.6	7 000	9 200	7217C	1.87	
	180	41	3	1.1	150	122	159	133	4 400	5 500	7317	4.53	
	180	41	3	1.1	137	112	145	122	3 300	4 400	7317B	4.53	

Notes 1) Rotation speed limits shown above are applicable to machined cage bearings.

Rotation speed limits of pressed cage bearings should be kept to under 80 % of this value.

For bearings with 15° contact angle, this figure is applied to the high precision bearings ranked higher than class 5, used with machined cage or molded cage.

2) B, C or no indication after the bearing number indicates nominal contact angle of 40°, 15° and 30° respectively.

Remark) Standard cage types used for the above bearings are described earlier in this section.

Single-row angular contact ball bearings

d (85) – (105) mm

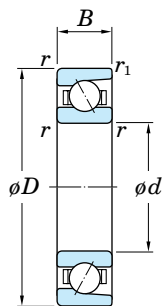

With machined cage

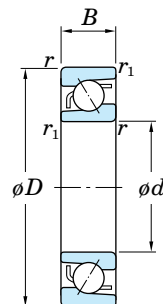

With pressed cage

d	Boundary dimensions (mm)				Basic load ratings (kN)				Limiting speeds ¹⁾ (min ⁻¹)		Bearing No.	(Refer.) Mass (kg)	
	D	B	r min.	r_1 min.	With machined cage		With pressed cage		Grease lub.	Oil lub.			
	C_r	C_{0r}	C_r	C_{0r}									
85	210	52	4	1.5	204	180	–	–	3 000	3 900	7417	8.54	
	210	52	4	1.5	189	167	–	–	2 600	3 600	7417B	8.54	
90	140	24	1.5	1	65.2	63.3	–	–	5 100	6 400	7018	1.26	
	140	24	1.5	1	71.7	69.1	–	–	7 100	9 400	7018C	1.26	
	160	30	2	1	113	96.7	118	103	4 700	5 900	7218	2.30	
	160	30	2	1	102	88.0	107	93.8	3 500	4 700	7218B	2.30	
	160	30	2	1	123	105	128	112	6 500	8 600	7218C	2.30	
	190	43	3	1.1	161	135	171	147	4 200	5 200	7318	5.30	
	190	43	3	1.1	148	124	156	135	3 100	4 200	7318B	5.30	
	225	54	4	1.5	216	196	–	–	2 800	3 700	7418	11.4	
	225	54	4	1.5	200	182	–	–	2 500	3 400	7418B	11.4	
	95	145	24	1.5	1	66.6	67.1	–	–	4 800	6 000	7019	1.32
145		24	1.5	1	73.4	73.4	–	–	6 700	8 900	7019C	1.32	
170		32	2.1	1.1	122	103	128	111	4 400	5 500	7219	2.78	
170		32	2.1	1.1	111	94.0	116	101	3 300	4 400	7219B	2.78	
170		32	2.1	1.1	133	112	139	120	6 100	8 100	7219C	2.78	
200		45	3	1.1	172	149	183	162	4 000	4 900	7319	6.12	
200		45	3	1.1	158	137	167	149	3 000	4 000	7319B	6.12	
100		150	24	1.5	1	68.4	70.6	–	–	4 700	5 900	7020	1.37
	150	24	1.5	1	61.2	63.6	–	–	3 500	4 700	7020B	1.37	
	150	24	1.5	1	75.3	77.2	–	–	6 500	8 600	7020C	1.37	
	180	34	2.1	1.1	137	117	144	126	4 100	5 200	7220	3.32	
	180	34	2.1	1.1	124	107	130	115	3 100	4 200	7220B	3.32	
	180	34	2.1	1.1	149	127	156	136	5 700	7 600	7220C	3.32	
	215	47	3	1.1	184	161	207	194	3 600	4 600	7320	7.53	
	215	47	3	1.1	168	148	190	178	2 700	3 600	7320B	7.53	
	105	160	26	2	1	79.8	81.9	–	–	4 400	5 500	7021	1.73
		190	36	2.1	1.1	149	132	–	–	3 900	4 900	7221	3.95
190		36	2.1	1.1	135	121	–	–	2 900	3 900	7221B	3.95	

Notes 1) Rotation speed limits shown above are applicable to machined cage bearings.

Rotation speed limits of pressed cage bearings should be kept to under 80 % of this value.

For bearings with 15° contact angle, this figure is applied to the high precision bearings ranked higher than class 5, used with machined cage or molded cage.

2) B, C or no indication after the bearing number indicates nominal contact angle of 40°, 15° and 30° respectively.

Remark) Standard cage types used for the above bearings are described earlier in this section.

d (105) – 180 mm

d	Boundary dimensions (mm)				Basic load ratings (kN)				Limiting speeds (min ⁻¹)		Bearing ¹⁾ No.	(Refer.) Mass (kg)
	D	B	$r_{\min.}$	$r_{1\min.}$	With machined cage		With pressed cage		Grease lub.	Oil lub.		
					C_r	C_{0r}	C_r	C_{0r}				
105	225	49	3	1.1	208	193	–	–	3 500	4 400	7321 7321B	8.62
	225	49	3	1.1	191	177	–	–	2 600	3 500		8.62
110	170	28	2	1	91.9	92.8	–	–	4 200	5 200	7022 7222 7222B	2.14
	200	38	2.1	1.1	162	148	–	–	3 700	4 600		4.65
	200	38	2.1	1.1	147	135	–	–	2 800	3 700		4.65
110	240	50	3	1.1	232	226	–	–	3 200	4 000	7322 7322B	10.1
	240	50	3	1.1	213	208	–	–	2 400	3 200		10.1
120	180	28	2	1	96.6	103	–	–	3 900	4 900	7024 7224 7224B	2.27
	215	40	2.1	1.1	174	166	–	–	3 400	4 300		5.49
	215	40	2.1	1.1	158	151	–	–	2 600	3 400		5.49
120	260	55	3	1.1	246	252	–	–	3 000	3 700	7324 7324B	12.6
	260	55	3	1.1	225	231	–	–	2 200	3 000		12.6
130	200	33	2	1	117	125	–	–	3 500	4 400	7026 7026B 7226	3.43
	200	33	2	1	105	113	–	–	2 600	3 500		3.43
	230	40	3	1.1	196	198	–	–	3 200	4 000		6.21
130	230	40	3	1.1	177	180	–	–	2 400	3 200	7226B 7326 7326B	6.21
	280	58	4	1.5	301	329	–	–	2 700	3 400		15.4
	280	58	4	1.5	250	268	–	–	2 100	2 700		15.4
	280	58	4	1.5	250	268	–	–	2 100	2 700		15.4
140	210	33	2	1	120	133	–	–	3 300	4 100	7028 7028B 7228	3.64
	210	33	2	1	107	119	–	–	2 500	3 300		3.64
	250	42	3	1.1	218	234	–	–	2 900	3 600		7.76
140	250	42	3	1.1	197	213	–	–	2 200	2 900	7228B 7328 7328B	7.76
	300	62	4	1.5	329	374	–	–	2 500	3 200		18.8
	300	62	4	1.5	302	344	–	–	1 900	2 500		18.8
	300	62	4	1.5	302	344	–	–	1 900	2 500		18.8
150	225	35	2.1	1.1	137	154	–	–	3 000	3 800	7030 7030B 7230	4.43
	225	35	2.1	1.1	122	138	–	–	2 300	3 000		4.43
	270	45	3	1.1	248	280	–	–	2 700	3 300		9.75
150	270	45	3	1.1	225	254	–	–	2 000	2 700	7230B 7330 7330B	9.75
	320	65	4	1.5	348	414	–	–	2 300	2 900		22.4
	320	65	4	1.5	318	380	–	–	1 800	2 300		22.4
	320	65	4	1.5	318	380	–	–	1 800	2 300		22.4
160	240	38	2.1	1.1	155	176	–	–	2 800	3 500	7032 7032B 7232	5.45
	240	38	2.1	1.1	139	158	–	–	2 100	2 800		5.45
	290	48	3	1.1	230	263	–	–	2 500	3 100		12.1
160	290	48	3	1.1	238	279	–	–	1 800	2 500	7232B 7332B	12.1
	340	68	4	1.5	332	416	–	–	1 600	2 200		26.4
170	260	42	2.1	1.1	186	214	–	–	2 600	3 200	7034 7034B 7234B	7.58
	260	42	2.1	1.1	166	193	–	–	1 900	2 600		7.77
	310	52	4	1.5	245	300	–	–	1 700	2 300		15.1
170	360	72	4	1.5	355	444	–	–	1 500	2 000	7334B	31.2
	360	72	4	1.5	355	444	–	–	1 500	2 000		31.2
180	280	46	2.1	1.1	212	253	–	–	2 400	3 000	7036 7036B 7236B	10.1
	280	46	2.1	1.1	190	228	–	–	1 800	2 400		10.2
	320	52	4	1.5	265	329	–	–	1 600	2 200		15.7
180	380	75	4	1.5	373	488	–	–	1 400	1 900	7336B	40.0
	380	75	4	1.5	373	488	–	–	1 400	1 900		40.0

Note 1) B, C or no indication after the bearing number indicates nominal contact angle of 40°, 15° and 30° respectively.

Remark) Standard cage types used for the above bearings are described earlier in this section.

Single-row angular contact ball bearings

d 190 – 200 mm

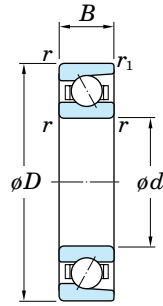

With machined cage

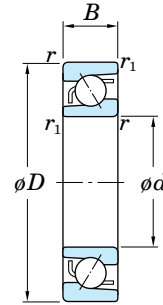

With pressed cage

d	Boundary dimensions (mm)				Basic load ratings (kN)				Limiting speeds (min ⁻¹)		Bearing ¹⁾ No.	(Refer.) Mass (kg)
	D	B	$r_{\min.}$	$r_1_{\min.}$	With machined cage		With pressed cage		Grease lub.	Oil lub.		
					C_r	C_{0r}	C_r	C_{0r}				
190	290	46	2.1	1.1	217	268	—	—	2 300	2 800	7038	10.8
	290	46	2.1	1.1	194	241	—	—	1 700	2 300	7038B	10.8
	340	55	4	1.5	273	353	—	—	1 500	2 000	7238B	18.8
	400	78	5	2	411	548	—	—	1 300	1 800	7338B	45.5
200	360	58	4	1.5	292	384	—	—	1 400	1 900	7240B	22.4
	420	80	5	2	432	602	—	—	1 200	1 700	7340B	52.0

Note 1) B, C or no indication after the bearing number indicates nominal contact angle of 40°, 15° and 30° respectively.

Remark) Standard cage types used for the above bearings are described earlier in this section.



Double-row angular contact ball bearings

d 15 – 45 mm

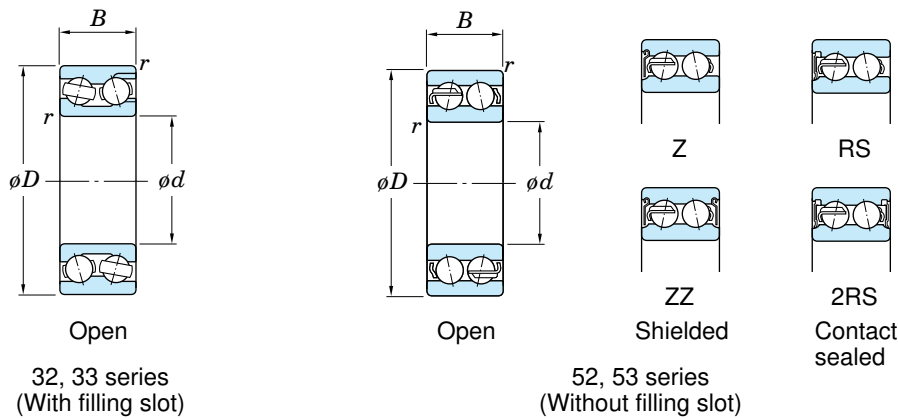

Boundary dimensions (mm)				Basic load ratings (kN)				Limiting speeds (min ⁻¹)			Bearing No.			(Refer.) Mass (kg)
d	D	B	$r_{min.}$	Open		Shielded-sealed		Grease lub.		Oil lub.	Open	Shielded ZZ	Sealed 2RS	
				C_r	C_{0r}	C_r	C_{0r}	$\left[\begin{matrix} \text{Open} \\ Z, ZZ \end{matrix} \right]$	(RS, 2RS)	$\left[\begin{matrix} \text{Open} \\ Z \end{matrix} \right]$				
15	35	15.9	0.6	9.70	7.45	–	–	12 000	–	16 000	3202	–	–	0.072
	42	19	1	15.2	11.9	–	–	10 000	–	14 000	3302	–	–	0.132
17	40	17.5	0.6	13.8	10.8	–	–	11 000	–	14 000	3203	–	–	0.100
	40	17.5	0.6	13.2	8.15	12.7	8.35	11 000	11 000	14 000	5203	ZZ	2RS	0.091
	47	22.2	1	21.7	17.1	–	–	9 400	–	13 000	3303	–	–	0.192
20	47	20.6	1	17.2	15.0	–	–	9 000	–	12 000	3204	–	–	0.170
	47	20.6	1	19.7	12.6	16.0	10.8	8 800	8 800	12 000	5204	ZZ	2RS	0.120
	52	22.2	1.1	20.8	18.4	–	–	8 200	–	11 000	3304	–	–	0.230
	52	22.2	1.1	24.7	15.0	19.8	12.8	8 300	8 300	11 000	5304	ZZ	2RS	0.230
25	52	20.6	1	18.9	18.2	–	–	7 800	–	10 000	3205	–	–	0.190
	52	20.6	1	21.4	14.8	18.9	13.8	7 700	7 700	10 000	5205	ZZ	2RS	0.190
	62	25.4	1.1	28.9	26.5	–	–	6 800	–	9 100	3305	–	–	0.369
	62	25.4	1.1	32.7	20.8	27.5	18.5	6 900	6 900	9 200	5305	ZZ	2RS	0.340
30	62	23.8	1	27.3	27.0	–	–	6 500	–	8 700	3206	–	–	0.320
	62	23.8	1	29.7	21.3	25.4	18.3	6 400	6 400	8 600	5206	ZZ	2RS	0.290
	72	30.2	1.1	38.1	36.1	–	–	5 800	–	7 800	3306	–	–	0.585
	72	30.2	1.1	41.0	28.5	34.3	25.2	5 800	5 800	7 700	5306	ZZ	2RS	0.510
35	72	27	1.1	36.8	37.5	–	–	5 600	–	7 500	3207	–	–	0.480
	72	27	1.1	39.2	29.0	31.7	24.6	5 500	5 500	7 300	5207	ZZ	2RS	0.430
	80	34.9	1.5	48.6	46.8	–	–	5 200	–	7 000	3307	–	–	0.816
	80	34.9	1.5	51.2	36.2	46.1	32.8	5 100	5 100	6 800	5307	ZZ	2RS	0.790
40	80	30.2	1.1	42.0	43.9	–	–	5 000	–	6 700	3208	–	–	0.650
	80	30.2	1.1	44.4	33.6	36.5	29.1	5 000	5 000	6 700	5208	ZZ	2RS	0.570
	90	36.5	1.5	54.1	53.8	–	–	4 600	–	6 100	3308	–	–	1.07
	90	36.5	1.5	62.7	45.4	51.4	37.8	4 600	4 600	6 100	5308	ZZ	2RS	1.05
45	85	30.2	1.1	45.4	51.4	–	–	4 600	–	6 100	3209	–	–	0.710
	85	30.2	1.1	49.9	38.4	41.7	33.9	4 600	4 600	6 100	5209	ZZ	2RS	0.620
	100	39.7	1.5	66.1	67.3	–	–	4 100	–	5 500	3309	–	–	1.42
	100	39.7	1.5	75.1	55.7	68.9	51.4	4 100	4 100	5 500	5309	ZZ	2RS	1.42

Remark) Standard cage types used for the above bearings are described earlier in this section.

d 50 – 100 mm

Boundary dimensions (mm)				Basic load ratings(kN)				Limiting speeds (min ⁻¹)			Bearing No.			(Refer.) Mass (kg)
<i>d</i>	<i>D</i>	<i>B</i>	<i>r</i> _{min.}	Open		Shielded-sealed		Grease lub.		Oil lub.	Open	Shielded ZZ	Sealed 2RS	
				<i>C</i> _r	<i>C</i> _{0r}	<i>C</i> _r	<i>C</i> _{0r}	{ Open Z, ZZ }	(RS, 2RS)	{ Open Z }				
50	90	30.2	1.1	45.1	52.1	–	–	4 300	–	5 700	3210	–	–	0.760
	90	30.2	1.1	53.3	43.6	44.1	37.9	4 300	4 300	5 600	5210	ZZ	2RS	0.670
	110	44.4	2	86.1	88.6	–	–	3 800	–	5 000	3310	–	–	1.95
	110	44.4	2	88.5	67.0	81.8	62.2	3 600	3 600	4 800	5310	ZZ	2RS	1.93
55	100	33.3	1.5	50.9	60.2	–	–	3 900	–	5 100	3211	–	–	1.05
	100	33.3	1.5	65.9	55.2	52.9	44.7	3 800	3 800	5 100	5211	ZZ	2RS	0.960
	120	49.2	2	101	106	–	–	3 400	–	4 500	3311	–	–	2.53
	120	49.2	2	110	85.1	95.7	74.3	3 300	3 300	4 500	5311	ZZ	2RS	2.30
60	110	36.5	1.5	64.0	76.8	–	–	3 500	–	4 700	3212	–	–	1.40
	110	36.5	1.5	74.4	60.8	62.6	55.9	3 500	3 500	4 700	5212	ZZ	2RS	1.36
	130	54	2.1	125	132	–	–	3 100	–	4 200	3312	–	–	3.24
	130	54	2.1	126	98.7	110	87.1	3 100	3 100	4 100	5312	ZZ	2RS	3.16
65	120	38.1	1.5	76.4	97.4	–	–	3 200	–	4 300	3213	–	–	1.75
	120	38.1	1.5	86.9	75.3	69.2	63.1	3 200	3 200	4 300	5213	ZZ	2RS	1.66
	140	58.7	2.1	142	153	–	–	2 900	–	3 900	3313	–	–	4.08
	140	58.7	2.1	142	113	142	113	2 900	2 900	3 900	5313	ZZ	2RS	3.91
70	125	39.7	1.5	77.9	96.4	–	–	3 100	–	4 100	3214	–	–	1.92
	125	39.7	1.5	94.5	82.6	76.3	70.3	3 100	3 100	4 100	5214	ZZ	2RS	1.81
	150	63.5	2.1	151	160	–	–	2 700	–	3 600	3314	–	–	5.04
	150	63.5	2.1	160	129	160	129	2 700	2 700	3 600	5314	ZZ	2RS	4.89
75	130	41.3	1.5	92.4	120	–	–	2 900	–	3 900	3215	–	–	2.10
	160	68.3	2.1	169	189	–	–	2 500	–	3 300	3315	–	–	6.16
	160	68.3	2.1	174	147	174	147	2 500	2 500	3 300	5315	ZZ	2RS	5.97
80	140	44.4	2	97.5	121	–	–	2 700	–	3 600	3216	–	–	2.64
	170	68.3	2.1	184	213	–	–	2 400	–	3 100	3316	–	–	6.93
85	150	49.2	2	114	143	–	–	2 500	–	3 400	3217	–	–	3.39
	180	73	3	188	219	–	–	2 200	–	3 000	3317	–	–	8.30
90	160	52.4	2	132	167	–	–	2 400	–	3 100	3218	–	–	4.14
	190	73	3	205	242	–	–	2 100	–	2 800	3318	–	–	9.23
95	170	55.6	2.1	152	193	–	–	2 200	–	3 000	3219	–	–	5.00
	200	77.8	3	218	270	–	–	2 000	–	2 600	3319	–	–	10.9
100	180	60.3	2.1	172	221	–	–	2 100	–	2 800	3220	–	–	6.10
	215	82.6	3	249	324	–	–	1 800	–	2 500	3320	–	–	13.5

Remark) Standard cage types used for the above bearings are described earlier in this section.

KOYO



Self-aligning ball bearings

Self-aligning ball bearings have a spherical outer ring raceway, the center of whose curvature meets that of the bearing itself, so that the inner ring, balls and cage continue to rotate, aligning themselves if they have become misaligned within design limits.

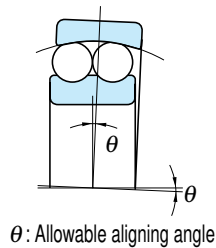

This type of bearing is suitable when the displacement of the centers around which the shaft and housing rotate and shaft deflection are likely to occur.

Bearings with a tapered bore can easily be fit to the shaft with an adapter assembly.

Self-aligning ball bearings

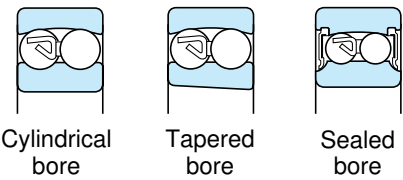

Bore diameter **10 – 100 mm**

Adapter assemblies

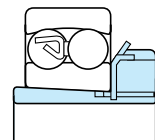

Bore diameter **17 – 90 mm**

Boundary dimensions	The dimensions of standard series are as specified in JIS B 1512.
Tolerances	As specified in JIS B 1514, class 0.
Radial internal clearance	As specified in JIS B 1520. (refer to Table 2-5 on p. A 14.)
Standard cages	<ul style="list-style-type: none"> Staggered type pressed steel cage [application : all dimensional range of 12, 13, 22...2RS and 23...2RS series] Snap type pressed steel cage [application : all dimensional range of 22 series and those of No. 2300 thru 2316] Copper alloy machined cage (application : bearings of No. 2317 thru 2320)
Allowable aligning angle	<ul style="list-style-type: none"> 12 and 22 series 0.044 rad (2.5°) 13 and 23 series 0.052 rad (3°) 22...2RS and 23...2RS series.. 0.026 rad (1.5°)

Dynamic equivalent radial load

$$P_r = XF_r + YF_a$$

$F_a / F_r \leq e$		$F_a / F_r > e$	
X	Y	X	Y
1	Y_1	0.65	Y_2

Static equivalent radial load

$$P_{0r} = F_r + Y_0 F_a$$

Self-aligning ball bearings

d 10 – 35 mm

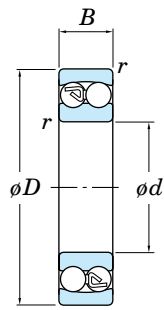

Cylindrical bore



Sealed

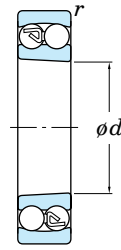

Tapered bore

Taper $1/12$

[Note] Protruding distance of balls

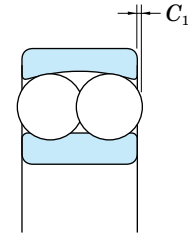

Balls of the following bearing protrude by C_1 from the bearing side.

Bearing No.	C_1 (mm)
2216	0.2 (approx.)

Boundary dimensions (mm)				Basic load ratings (kN)				Limiting speeds (min ⁻¹)			Bearing No.			(Refer.)Mass (kg)	
d	D	B	$r_{min.}$	Open		Sealed type		Grease lub.			Cylindrical bore Open	Sealed type 2RS	Tapered bore Open	Cylindrical bore	Tapered bore
				C_r	C_{0r}	C_r	C_{0r}	Open	2RS	Open					
10	30	9	0.6	5.50	1.20	—	—	23 000	—	28 000	1200	—	—	0.034	—
	30	14	0.6	7.40	1.60	5.40	1.20	23 000	15 000	29 000	2200	2RS	—	0.047	—
12	32	10	0.6	5.60	1.25	—	—	21 000	—	26 000	1201	—	—	0.040	—
	32	14	0.6	7.65	1.75	5.60	1.25	21 000	14 000	26 000	2201	2RS	—	0.053	—
	37	12	1	9.40	2.15	—	—	18 000	—	22 000	1301	—	—	0.067	—
15	37	17	1	9.70	2.30	—	—	16 000	—	22 000	2301	—	—	0.095	—
	35	11	0.6	7.45	1.75	—	—	18 000	—	22 000	1202	—	—	0.049	—
	35	14	0.6	7.70	1.85	7.45	1.75	18 000	12 000	22 000	2202	2RS	—	0.060	—
	42	13	1	9.55	2.30	—	—	16 000	—	20 000	1302	—	—	0.094	—
17	42	17	1	12.1	2.90	9.55	2.30	14 000	11 000	20 000	2302	2RS	—	0.114	—
	40	12	0.6	7.90	2.00	—	—	16 000	—	20 000	1203	—	—	0.073	—
	40	16	0.6	9.80	2.40	7.90	2.00	16 000	11 000	20 000	2203	2RS	—	0.088	—
	47	14	1	12.5	3.20	—	—	14 000	—	17 000	1303	—	—	0.130	—
20	47	19	1	14.5	3.60	12.5	3.20	13 000	9 400	18 000	2303	2RS	—	0.158	—
	47	14	1	9.90	2.60	—	—	14 000	—	17 000	1204	—	1204K	0.120	0.118
	47	18	1	12.6	3.30	9.90	2.60	14 000	9 100	17 000	2204	2RS	2204K	0.140	0.136
	52	15	1.1	12.4	3.30	—	—	13 000	—	15 000	1304	—	1304K	0.163	0.161
25	52	21	1.1	18.0	4.70	12.4	3.35	11 000	8 300	15 000	2304	2RS	2304K	0.209	0.205
	52	15	1	12.1	3.30	—	—	12 000	—	14 000	1205	—	1205K	0.141	0.138
	52	18	1	12.6	3.50	12.1	3.30	12 000	7 900	15 000	2205	2RS	2205K	0.163	0.158
	62	17	1.1	18.0	5.00	—	—	9 900	—	12 000	1305	—	1305K	0.257	0.252
30	62	24	1.1	24.4	6.60	17.6	4.95	9 400	6 600	13 000	2305	2RS	2305K	0.335	0.327
	62	16	1	15.6	4.65	—	—	9 900	—	12 000	1206	—	1206K	0.220	0.216
	62	20	1	15.6	4.65	15.6	4.65	10 000	6 600	12 000	2206	2RS	2206K	0.260	0.254
	72	19	1.1	21.3	6.30	—	—	8 700	—	11 000	1306	—	1306K	0.387	0.381
35	72	27	1.1	31.4	8.75	21.3	6.30	8 000	5 800	11 000	2306	2RS	2306K	0.500	0.489
	72	17	1.1	15.8	5.10	—	—	8 500	—	10 000	1207	—	1207K	0.323	0.317
	72	23	1.1	21.6	6.60	15.8	5.10	8 500	5 700	10 000	2207	2RS	2207K	0.403	0.396
	80	21	1.5	25.1	7.85	—	—	7 600	—	9 300	1307	—	1307K	0.510	0.502
80	31	1.5	39.4	11.3	25.1	7.85	7 100	5 100	9 800	2307	2RS	2307K	0.675	0.657	

Remark) Standard cage types used for the above bearings are described earlier in this section.

d 40 – 90 mm

Boundary dimensions (mm)				Basic load ratings (kN)				Limiting speeds (min ⁻¹)			Bearing No.			(Refer.) Mass (kg)	
d	D	B	$r_{min.}$	Open		Sealed type		Grease lub.		Oil lub.	Cylindrical bore	Sealed type	Tapered bore	Cylindrical bore	Tapered bore
				C_r	C_{or}	C_r	C_{or}	Open	2RS	Open	Open	2RS	Open		
40	80	18	1.1	19.2	6.50	–	–	7 500	–	9 200	1208	–	1208K	0.417	0.411
	80	23	1.1	22.4	7.40	19.2	6.50	7 600	5 000	9 300	2208	2RS	2208K	0.505	0.494
	90	23	1.5	29.5	9.70	–	–	6 900	–	8 400	1308	–	1308K	0.715	0.704
	90	33	1.5	44.9	13.5	29.5	9.70	6 200	4 600	8 600	2308	2RS	2308K	0.925	0.903
45	85	19	1.1	21.8	7.35	–	–	7 000	–	8 500	1209	–	1209K	0.465	0.459
	85	23	1.1	23.3	8.15	21.8	7.35	7 000	4 600	8 500	2209	2RS	2209K	0.545	0.533
	100	25	1.5	38.1	12.7	–	–	6 100	–	7 500	1309	–	1309K	0.957	0.942
	100	36	1.5	54.4	16.7	38.1	12.7	5 600	4 100	7 700	2309	2RS	2309K	1.23	1.20
50	90	20	1.1	22.7	8.10	–	–	6 500	–	7 900	1210	–	1210K	0.525	0.515
	90	23	1.1	23.3	8.50	22.7	8.10	6 500	4 300	7 900	2210	2RS	2210K	0.590	0.577
	110	27	2	43.4	14.1	–	–	5 600	–	6 800	1310	–	1310K	1.21	1.19
	110	40	2	64.6	20.3	43.4	14.1	5 100	3 700	7 000	2310	2RS	2310K	1.64	1.60
55	100	21	1.5	26.8	10.0	–	–	5 800	–	7 100	1211	–	1211K	0.705	0.693
	100	25	1.5	26.8	10.0	26.8	10.0	5 800	3 900	7 100	2211	2RS	2211K	0.810	0.792
	120	29	2	51.3	17.9	–	–	5 000	–	6 200	1311	–	1311K	1.58	1.56
	120	43	2	75.3	24.0	51.3	17.9	4 600	3 400	6 400	2311	2RS	2311K	2.10	2.05
60	110	22	1.5	30.2	11.5	–	–	5 200	–	6 400	1212	–	1212K	0.900	0.885
	110	28	1.5	34.1	12.6	30.2	11.5	5 300	3 500	6 500	2212	2RS	2212K	1.09	1.07
	130	31	2.1	57.2	20.8	–	–	4 500	–	5 500	1312	–	1312K	1.96	1.93
	130	46	2.1	87.2	28.3	57.1	20.8	4 200	3 000	5 800	2312	2RS	2312K	2.60	2.53
65	120	23	1.5	31.0	12.5	–	–	4 800	–	5 800	1213	–	1213K	1.15	1.13
	120	31	1.5	43.5	16.4	31.0	12.5	4 900	3 200	5 900	2213	2RS	2213K	1.46	1.43
	140	33	2.1	61.7	22.9	–	–	4 300	–	5 200	1313	–	1313K	2.45	2.41
	140	48	2.1	95.8	32.5	62.1	22.9	3 800	2 900	5 300	2313	2RS	2313K	3.23	3.15
70	125	24	1.5	34.6	13.8	–	–	4 600	–	5 700	1214	–	–	1.26	–
	125	31	1.5	43.9	17.1	34.6	13.8	4 600	3 100	5 600	2214	2RS	–	1.52	–
	150	35	2.1	74.0	27.7	–	–	4 000	–	4 900	1314	–	–	2.99	–
	150	51	2.1	89.6	31.7	74.1	27.7	3 600	2 600	4 900	2314	2RS	–	4.23	–
75	130	25	1.5	38.8	15.7	–	–	4 300	–	5 300	1215	–	1215K	1.36	1.34
	130	31	1.5	44.2	17.8	38.8	15.7	4 300	2 900	5 300	2215	2RS	2215K	1.62	1.58
	160	37	2.1	78.9	29.9	–	–	4 000	–	4 900	1315	–	1315K	3.56	3.51
	160	55	2.1	103	36.8	81.8	30.5	3 400	2 600	4 600	2315	2RS	2315K	5.13	5.01
80	140	26	2	39.8	17.0	–	–	4 000	–	4 900	1216	–	1216K	1.67	1.64
	140	33	2	49.0	19.9	39.8	17.0	4 100	2 700	5 000	2216	2RS	2216K	2.01	1.97
	170	39	2.1	88.1	33.1	–	–	3 500	–	4 300	1316	–	1316K	4.18	4.12
	170	58	2.1	129	45.7	88.4	33.1	3 100	2 300	4 300	2316	2RS	2316K	6.10	5.96
85	150	28	2	49.2	20.8	–	–	3 800	–	4 600	1217	–	1217K	2.07	2.04
	150	36	2	58.3	23.6	49.2	20.8	3 800	2 500	4 600	2217	2RS	2217K	2.52	2.46
	180	41	3	97.3	37.8	–	–	3 300	–	4 000	1317	–	1317K	4.98	4.91
	180	60	3	141	51.5	–	–	3 000	–	4 100	2317	–	2317K	7.05	6.89
90	160	30	2	56.8	23.4	–	–	3 500	–	4 300	1218	–	1218K	2.52	2.48
	160	40	2	67.7	27.2	54.1	23.1	3 500	2 400	4 300	2218	2RS	2218K	3.40	3.33
	190	43	3	116	44.4	–	–	3 100	–	3 800	1318	–	1318K	5.80	5.71
	190	64	3	153	57.9	–	–	2 800	–	3 900	2318	–	2318K	8.44	8.25

Remark) Standard cage types used for the above bearings are described earlier in this section.

Self-aligning ball bearings

d 95 – 100 mm

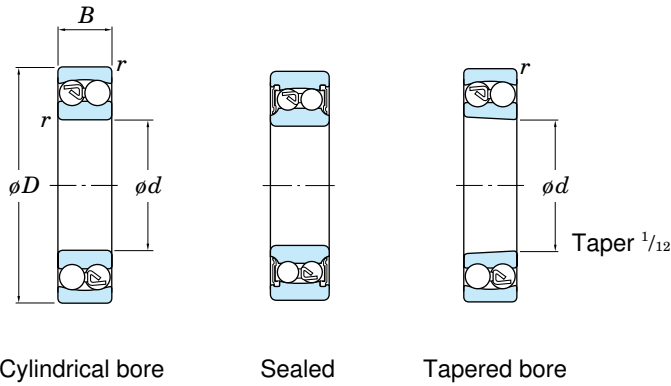

[Note] Protruding distance of balls

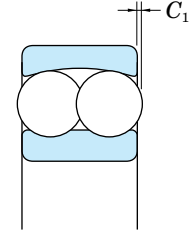

Balls of the following bearing protrude by C_1 from the bearing side.

Bearing No.	C_1 (mm)
1319	1.6
1320	2.5 (approx.)

Boundary dimensions (mm)				Basic load ratings (kN)				Limiting speeds (min ⁻¹)			Bearing No.			(Refer.) Mass (kg)	
d	D	B	$r_{min.}$	Open		Sealed type		Grease lub.		Oil lub.	Cylindrical bore	Sealed type	Tapered bore	Cylindrical bore	Tapered bore
				C_r	C_{0r}	C_r	C_{0r}	Open	2RS	Open	Open	2RS	Open		
95	170	32	2.1	57.0	24.3	—	—	3 300	—	4 000	1219	—	1219K	3.10	3.05
	170	43	2.1	82.7	34.3	60.8	26.8	3 300	2 200	4 000	2219	2RS	2219K	4.10	4.00
	200	45	3	132	50.8	—	—	2 900	—	3 600	1319	—	1319K	6.69	6.59
	200	67	3	166	64.8	—	—	2 700	—	3 700	2319	—	2319K	9.79	9.57
100	180	34	2.1	69.0	29.7	—	—	3 100	—	3 800	1220	—	1220K	3.70	3.64
	180	46	2.1	80.9	34.0	69.0	29.7	3 100	2 100	3 800	2220	2RS	2220K	4.98	4.87
	215	47	3	143	57.3	—	—	2 800	—	3 400	1320	—	1320K	8.30	8.19
	215	73	3	183	73.4	—	—	2 400	—	3 400	2320	—	2320K	12.4	12.1

Remark) Standard cage types used for the above bearings are described earlier in this section.



Adapter assemblies for self-aligning ball bearings

d_1 17 – 45 mm

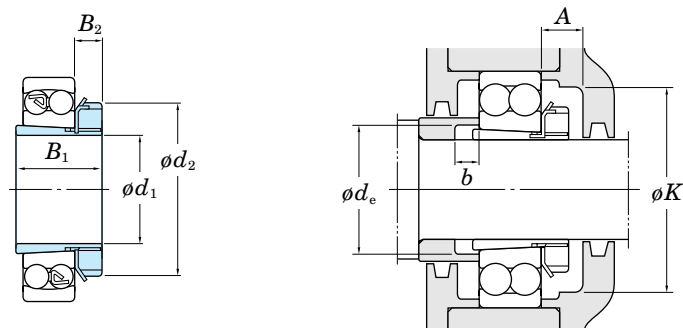

Boundary dimensions (mm)				Brg. bore (mm) d	Designations Bearing + adapter ass'y	Mounting dimensions (mm)				Mass Brg. + adapter ass'y (kg)	(Refer.)	
d_1	B_1	d_2	B_2			A min.	K min.	d_e min.	b min.		Adapter sleeve No.	Locknut No.
17	24	32	7	20	1204K+H204X	–	–	23	5	0.159	A204X	AN04
	28	32	7	20	2204K+H304X	–	–	24	5	0.181	A304X	AN04
	28	32	7	20	1304K+H304X	–	–	24	8	0.206	A304X	AN04
	31	32	7	20	2304K+H2304X	–	–	24	5	0.254	A2304X	AN04
20	26	38	8	25	1205K+H205X	15	45	28	5	0.208	A205X	AN05
	29	38	8	25	2205K+H305X	15	45	29	5	0.233	A305X	AN05
	29	38	8	25	1305K+H305X	15	45	29	6	0.327	A305X	AN05
	35	38	8	25	2305K+H2305X	15	45	29	5	0.414	A2305X	AN05
25	27	45	8	30	1206K+H206X	15	50	33	5	0.315	A206X	AN06
	31	45	8	30	2206K+H306X	15	50	34	5	0.363	A306X	AN06
	31	45	8	30	1306K+H306X	15	50	34	6	0.490	A306X	AN06
	38	45	8	30	2306K+H2306X	15	50	35	5	0.615	A2306X	AN06
30	29	52	9	35	1207K+H207X	17	58	38	5	0.442	A207X	AN07
	35	52	9	35	2207K+H307X	17	58	39	5	0.538	A307X	AN07
	35	52	9	35	1307K+H307X	17	58	39	7	0.644	A307X	AN07
	43	52	9	35	2307K+H2307X	17	58	40	5	0.822	A2307X	AN07
35	31	58	10	40	1208K+H208X	17	65	44	5	0.585	A208X	AN08
	36	58	10	40	2208K+H308X	17	65	44	5	0.683	A308X	AN08
	36	58	10	40	1308K+H308X	17	65	44	5	0.893	A308X	AN08
	46	58	10	40	2308K+H2308X	17	65	45	5	1.13	A2308X	AN08
40	33	65	11	45	1209K+H209X	17	72	49	5	0.686	A209X	AN09
	39	65	11	45	2209K+H309X	17	72	49	8	0.781	A309X	AN09
	39	65	11	45	1309K+H309X	17	72	49	5	1.19	A309X	AN09
	50	65	11	45	2309K+H2309X	17	72	50	5	1.48	A2309X	AN09
45	35	70	12	50	1210K+H210X	19	76	53	5	0.789	A210X	AN10
	42	70	12	50	2210K+H310X	19	76	54	10	0.880	A310X	AN10
	42	70	12	50	1310K+H310X	19	76	54	5	1.49	A310X	AN10
	55	70	12	50	2310K+H2310X	19	76	56	5	1.96	A2310X	AN10

d_1 50 – 90 mm

	Boundary dimensions (mm)				Brg. bore (mm) d	Designations Bearing + adapter ass'y	Mounting dimensions (mm)				Mass Brg. + adapter ass'y (kg)	(Refer.)	
	d_1	B_1	d_2	B_2			A min.	K min.	d_e min.	b min.		Adapter sleeve No.	Locknut No.
50	37	75	12	55	1211K+ H211X	19	85	60	6	1.00	A211X	AN11	
	45	75	12	55	2211K+ H311X	19	85	60	11	1.14	A311X	AN11	
	45	75	12	55	1311K+ H311X	19	85	60	6	1.91	A311X	AN11	
	59	75	12	55	2311K+ H2311X	19	85	61	6	2.47	A2311X	AN11	
55	38	80	13	60	1212K+ H212X	20	90	61	5	1.23	A212X	AN12	
	47	80	13	60	2212K+ H312X	20	90	65	9	1.46	A312X	AN12	
	47	80	13	60	1312K+ H312X	20	90	65	5	2.32	A312X	AN12	
	62	80	13	60	2312K+ H2312X	20	90	66	5	3.01	A2312X	AN12	
60	40	85	14	65	1213K+ H213X	21	96	70	5	1.53	A213X	AN13	
	50	85	14	65	2213K+ H313X	21	96	70	8	1.89	A313X	AN13	
	50	85	14	65	1313K+ H313X	21	96	70	5	2.87	A313X	AN13	
	65	85	14	65	2313K+ H2313X	21	96	72	5	3.71	A2313X	AN13	
65	43	98	15	75	1215K+ H215X	23	110	80	5	2.05	A215X	AN15	
	55	98	15	75	2215K+ H315X	23	110	80	12	2.41	A315X	AN15	
	55	98	15	75	1315K+ H315X	23	110	80	5	4.34	A315X	AN15	
	73	98	15	75	2315K+ H2315X	23	110	82	5	6.06	A2315X	AN15	
70	46	105	17	80	1216K+ H216X	25	120	85	5	2.52	A216X	AN16	
	59	105	17	80	2216K+ H316X	25	120	86	12	3.00	A316X	AN16	
	59	105	17	80	1316K+ H316X	25	120	86	5	5.15	A316X	AN16	
	78	105	17	80	2316K+ H2316X	25	120	87	5	7.24	A2316X	AN16	
75	50	110	18	85	1217K+ H217X	27	128	90	6	3.06	A217X	AN17	
	63	110	18	85	2217K+ H317X	27	128	91	12	3.64	A317X	AN17	
	63	110	18	85	1317K+ H317X	27	128	91	6	6.09	A317X	AN17	
	82	110	18	85	2317K+ H2317X	27	128	94	6	8.34	A2317X	AN17	
80	52	120	18	90	1218K+ H218X	28	139	95	6	3.67	A218X	AN18	
	65	120	18	90	2218K+ H318X	28	139	96	10	4.70	A318X	AN18	
	65	120	18	90	1318K+ H318X	28	139	96	6	7.08	A318X	AN18	
	86	120	18	90	2318K+ H2318X	28	139	99	6	9.94	A2318X	AN18	
85	55	125	19	95	1219K+ H219X	29	145	101	7	4.42	A219X	AN19	
	68	125	19	95	2219K+ H319X	29	145	102	9	5.56	A319X	AN19	
	68	125	19	95	1319K+ H319X	29	145	102	7	8.15	A319X	AN19	
	90	125	19	95	2319K+ H2319X	29	145	105	7	11.5	A2319X	AN19	
90	58	130	20	100	1220K+ H220X	30	150	106	7	5.13	A220X	AN20	
	71	130	20	100	2220K+ H320X	30	150	107	8	6.56	A320X	AN20	
	71	130	20	100	1320K+ H320X	30	150	107	7	9.88	A320X	AN20	
	97	130	20	100	2320K+ H2320X	30	150	110	7	14.2	A2320X	AN20	

KOYO

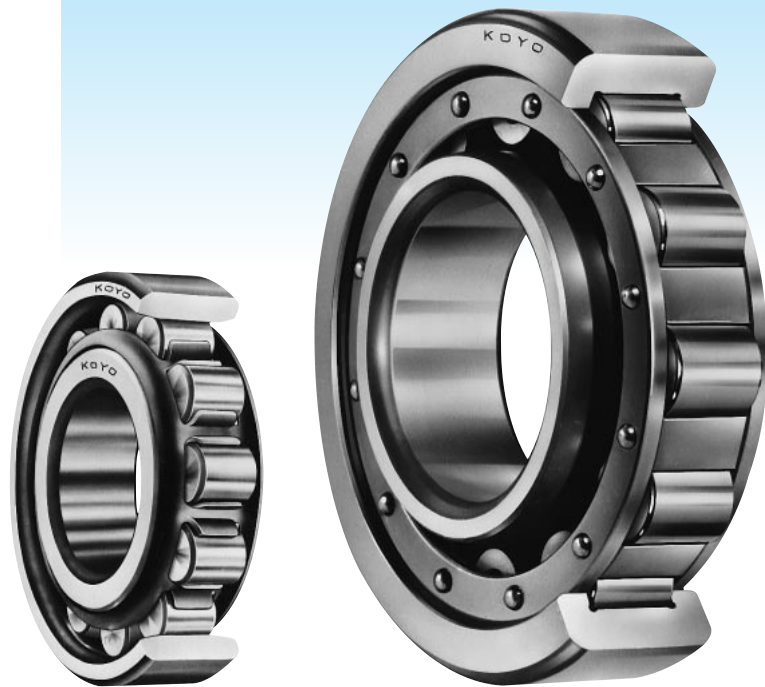

Cylindrical roller bearings

Cylindrical roller bearings feature high radial load capacity because the rollers and raceway are in linear contact. These bearings are suitable for applications that involve heavy radial and impact loading.

They are also appropriate for high-speed applications in that they can be machined very accurately due to their structure.

Having a separable inner ring or outer ring, these bearings can be mounted and dismounted easily.

Cylindrical roller bearings

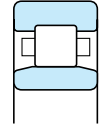

Bore diameter **20 – 200 mm**

■ Cylindrical roller bearings

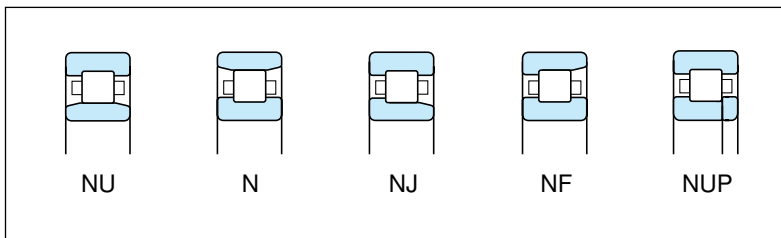

- The NU and N types exhibit their best performance when used as free side bearings since they adjust to the shaft's axial movement, to a certain extent, relative to the housing position.
- The NJ and NF types carry axial load in one direction, while the NUP type can carry a certain degree of axial load in both directions.

Cylindrical roller bearings

Boundary dimensions	The dimensions of standard series are as specified in JIS B 1512.																																																											
Tolerances	As specified in JIS B 1514.																																																											
	<p>Tolerances of roller set bore diameter F_w and roller set outside diameter E_w of interchangeable bearings are as follows : Unit μm</p> <table border="1" style="width: 100%; border-collapse: collapse; text-align: center;"> <thead> <tr> <th colspan="2" style="text-align: left;">Nominal bore diameter d (mm)</th> <th colspan="2" style="text-align: left;">ΔF_w Roller set bore diameter deviation</th> <th colspan="2" style="text-align: left;">ΔE_w Roller set outside diameter deviation</th> </tr> <tr> <th style="text-align: left;">over</th> <th style="text-align: left;">up to</th> <th style="text-align: left;">upper</th> <th style="text-align: left;">lower</th> <th style="text-align: left;">upper</th> <th style="text-align: left;">lower</th> </tr> </thead> <tbody> <tr> <td>–</td> <td>20</td> <td>+10</td> <td>0</td> <td>0</td> <td>–10</td> </tr> <tr> <td>20</td> <td>50</td> <td>+15</td> <td>0</td> <td>0</td> <td>–15</td> </tr> <tr> <td>50</td> <td>120</td> <td>+20</td> <td>0</td> <td>0</td> <td>–20</td> </tr> <tr> <td>120</td> <td>200</td> <td>+25</td> <td>0</td> <td>0</td> <td>–25</td> </tr> <tr> <td>200</td> <td>250</td> <td>+30</td> <td>0</td> <td>0</td> <td>–30</td> </tr> <tr> <td>250</td> <td>315</td> <td>+35</td> <td>0</td> <td>0</td> <td>–35</td> </tr> <tr> <td>315</td> <td>400</td> <td>+40</td> <td>0</td> <td>0</td> <td>–40</td> </tr> <tr> <td>400</td> <td>500</td> <td>+45</td> <td>0</td> <td>–</td> <td>–</td> </tr> </tbody> </table> <p>Remark) Interchangeable bearings have an inner ring with rollers that can be matched with the outer ring, or an outer ring with rollers that can be matched with the inner ring, without affecting performance.</p>	Nominal bore diameter d (mm)		ΔF_w Roller set bore diameter deviation		ΔE_w Roller set outside diameter deviation		over	up to	upper	lower	upper	lower	–	20	+10	0	0	–10	20	50	+15	0	0	–15	50	120	+20	0	0	–20	120	200	+25	0	0	–25	200	250	+30	0	0	–30	250	315	+35	0	0	–35	315	400	+40	0	0	–40	400	500	+45	0	–
Nominal bore diameter d (mm)		ΔF_w Roller set bore diameter deviation		ΔE_w Roller set outside diameter deviation																																																								
over	up to	upper	lower	upper	lower																																																							
–	20	+10	0	0	–10																																																							
20	50	+15	0	0	–15																																																							
50	120	+20	0	0	–20																																																							
120	200	+25	0	0	–25																																																							
200	250	+30	0	0	–30																																																							
250	315	+35	0	0	–35																																																							
315	400	+40	0	0	–40																																																							
400	500	+45	0	–	–																																																							
Radial internal clearance	<ul style="list-style-type: none"> • Cylindrical bore and tapered bore bearings (refer to Table 2-7 on pp. A 16, 17.) • Motor bearings (refer to Table 2-6 on P. A 14.) 																																																											
Standard cages	<ul style="list-style-type: none"> • Pressed steel cage (supplementary code : //) • Copper alloy machined cage (supplementary code : FY) <p style="text-align: right;">} For application range, refer to Table 1.</p> <p>{ Copper alloy machined cages without rivets (LY) are also used for some special purposes. }</p>																																																											
Allowable misalignment	<p>Allowable misalignment of single-row cylindrical roller bearings depends on bearing type and specification.</p> <p>General values are as follows :</p> <p>1) When P_r / C_r is approx. 10% under load of normal use 0.000 6 – 0.000 9 rad (2' – 3')</p> <p>2) When P_r / C_r is approx. 6% under load lighter than 1) 0.001 2 rad (4')</p> <p>When very large allowable misalignment is required, consult Koyo.</p>																																																											
Equivalent radial load	<p>Dynamic equivalent radial load $P_r = F_r$</p> <p>Static equivalent radial load $P_{0r} = F_r$</p>																																																											
Allowable axial load	<p>Cylindrical roller bearings with ribs, including loose rib and thrust collar, on both inner and outer rings accommodate axial load to a certain extent.</p> <p>(NJ and NF types accommodate load applied in one direction : NUP type in both directions.)</p>																																																											

Table 1 Application of standard cages

Bearing series	Pressed cage	Machined cage
NU 10	–	1005 – 1092
NU, NJ, NUP, NF 2	204 – 220	204 – 264
NU, NJ, NUP 22	2204 – 2220	2204 – 2252
NU, NJ, NUP, NF 3	304 – 320	304 – 348
NU, NJ, NUP 23	2304 – 2320	2304 – 2340
NU, NJ, NUP, NF 4	406 – 420	406 – 430

Cylindrical roller bearings

d 20 – (45) mm

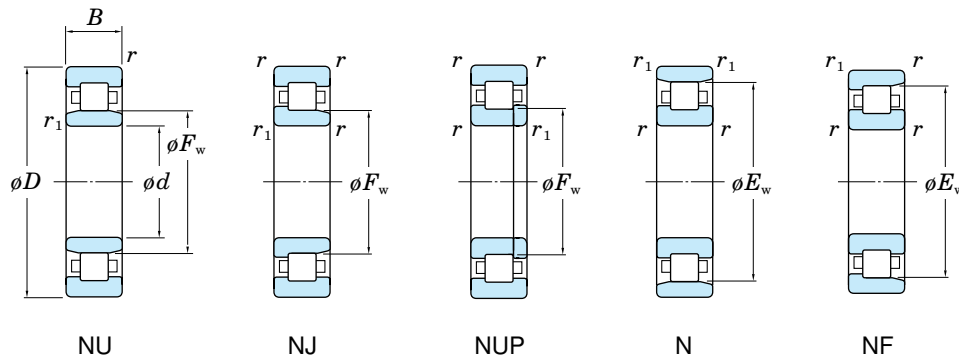

Boundary dimensions (mm)							Basic load ratings (kN)		Limiting speeds (min ⁻¹)		Bearing No.					(Refer.) Mass NU (kg)
d	D	B	$r_{\min.}$	$r_{1\min.}$	F_w	E_w	C_r	C_{0r}	Grease lub.	Oil lub.	NU	NJ	NUP	N	NF	
20	47	14	1	0.6	27	40	15.4	12.7	15 000	18 000	NU204	NJ	NUP	N	NF	0.108
	47	18	1	0.6	27	–	20.7	18.4	13 000	18 000	NU2204	NJ	–	–	–	0.146
	52	15	1.1	0.6	28.5	44.5	23.1	19.2	12 000	16 000	NU304	NJ	NUP	N	NF	0.147
	52	21	1.1	0.6	28.5	–	32.9	30.2	11 000	16 000	NU2304	–	–	–	–	0.212
25	47	12	0.6	0.3	30.5	–	14.3	13.1	15 000	18 000	NU1005	–	–	–	–	0.084
	52	15	1	0.6	32	45	17.7	15.7	13 000	16 000	NU205	NJ	NUP	N	NF	0.132
	52	18	1	0.6	32	–	23.7	22.8	12 000	16 000	NU2205	NJ	NUP	–	–	0.163
	62	17	1.1	1.1	35	53	29.3	25.2	10 000	14 000	NU305	NJ	NUP	N	NF	0.241
	62	24	1.1	1.1	35	–	42.7	40.9	9 100	14 000	NU2305	NJ	NUP	–	–	0.340
30	55	13	1	0.6	36.5	–	18.7	18.4	13 000	15 000	NU1006	–	–	–	–	0.121
	62	16	1	0.6	38.5	53.5	23.5	21.5	11 000	13 000	NU206	NJ	NUP	N	NF	0.200
	62	20	1	0.6	38.5	–	32.9	33.1	9 800	13 000	NU2206	NJ	NUP	–	–	0.262
	72	19	1.1	1.1	42	62	38.6	35.2	8 700	12 000	NU306	NJ	NUP	N	NF	0.358
	72	27	1.1	1.1	42	–	51.4	50.8	7 700	12 000	NU2306	NJ	NUP	–	–	0.500
	90	23	1.5	1.5	45	73	62.8	55.0	7 600	10 000	NU406	NJ	–	–	NF	0.753
35	62	14	1	0.6	42	–	22.6	23.2	11 000	13 000	NU1007	–	–	–	–	0.182
	72	17	1.1	0.6	43.8	61.8	33.6	31.5	9 500	11 000	NU207	NJ	NUP	N	NF	0.293
	72	23	1.1	0.6	43.8	–	49.0	51.2	8 500	11 000	NU2207	NJ	NUP	–	–	0.402
	80	21	1.5	1.1	46.2	68.2	49.6	46.9	7 900	10 000	NU307	NJ	NUP	N	NF	0.477
	80	31	1.5	1.1	46.2	–	64.4	65.7	7 000	10 000	NU2307	NJ	NUP	–	–	0.696
	100	25	1.5	1.5	53	83	75.2	68.9	6 600	8 800	NU407	NJ	–	–	NF	1.02
40	68	15	1	0.6	47	–	24.9	25.7	10 000	12 000	NU1008	–	–	–	–	0.223
	80	18	1.1	1.1	50	70	43.8	42.9	8 300	10 000	NU208	NJ	NUP	N	NF	0.366
	80	23	1.1	1.1	50	–	58.3	62.0	7 500	10 000	NU2208	NJ	NUP	–	–	0.490
	90	23	1.5	1.5	53.5	77.5	58.6	56.9	6 900	9 100	NU308	NJ	NUP	N	NF	0.657
	90	33	1.5	1.5	53.5	–	82.2	88.0	6 100	9 100	NU2308	NJ	NUP	–	–	0.956
	110	27	2	2	58	92	97.1	89.1	6 000	8 000	NU408	NJ	–	N	NF	1.30
45	75	16	1	0.6	52.5	–	31.0	33.8	9 200	11 000	NU1009	–	–	–	–	0.289
	85	19	1.1	1.1	55	75	46.1	46.9	7 700	9 200	NU209	NJ	NUP	N	NF	0.427
	85	23	1.1	1.1	55	–	61.4	67.8	6 900	9 200	NU2209	NJ	NUP	–	–	0.536
	100	25	1.5	1.5	58.5	86.5	78.8	77.5	6 200	8 300	NU309	NJ	NUP	N	NF	0.870

Remarks) Standard cage types used for the above bearings are shown in Table 1 earlier in this section. Please note that basic load ratings and rotation speed limits shown above indicate the value applicable to machined cage. When bearings with pressed cage are used, consult Koyo.

d (45) – 80 mm

d	Boundary dimensions (mm)						Basic load ratings (kN)		Limiting speeds (min ⁻¹)		Bearing No.					(Refer.) Mass NU (kg)
	D	B	r min.	r_1 min.	F_w	E_w	C_r	C_{0r}	Grease lub.	Oil lub.	NU	NJ	NUP	N	NF	
45	100	36	1.5	1.5	58.5	–	106	113	5 500	8 300	NU2309	NJ	NUP	–	–	1.25
	120	29	2	2	64.5	100.5	115	112	5 400	7 200	NU409	NJ	–	N	NF	1.64
50	80	16	1	0.6	57.5	–	33.6	36.8	8 400	9 900	NU1010	–	–	–	–	0.306
	90	20	1.1	1.1	60.4	80.4	48.2	51.0	7 100	8 500	NU210	NJ	NUP	N	NF	0.479
	90	23	1.1	1.1	60.4	–	64.2	73.6	6 400	8 500	NU2210	NJ	NUP	–	–	0.580
	110	27	2	2	65	95	92.2	93.4	5 600	7 500	NU310	NJ	NUP	N	NF	1.15
	110	40	2	2	65	–	128	142	5 000	7 500	NU2310	NJ	NUP	–	–	1.69
	130	31	2.1	2.1	70.8	110.8	139	136	4 900	6 600	NU410	NJ	–	–	NF	2.01
55	90	18	1.1	1	64.5	–	37.4	43.8	7 600	8 900	NU1011	–	–	–	–	0.445
	100	21	1.5	1.1	66.5	88.5	58.0	62.3	6 400	7 700	NU211	NJ	NUP	N	NF	0.640
	100	25	1.5	1.1	66.5	–	75.3	87.2	5 800	7 700	NU2211	NJ	NUP	–	–	0.780
	120	29	2	2	70.5	104.5	111	111	5 100	6 800	NU311	NJ	NUP	N	NF	1.44
	120	43	2	2	70.5	–	148	162	4 500	6 800	NU2311	NJ	NUP	–	–	2.10
	140	33	2.1	2.1	77.2	117.2	142	138	4 600	6 100	NU411	NJ	–	N	NF	2.51
60	95	18	1.1	1	69.5	–	42.1	50.0	7 000	8 300	NU1012	–	–	–	–	0.477
	110	22	1.5	1.5	73.5	97.5	71.9	79.9	5 800	7 000	NU212	NJ	NUP	N	NF	0.823
	110	28	1.5	1.5	73.5	–	101	123	5 200	7 000	NU2212	NJ	NUP	–	–	1.07
	130	31	2.1	2.1	77	113	124	126	4 700	6 300	NU312	NJ	NUP	N	NF	1.83
	130	46	2.1	2.1	77	–	168	188	4 200	6 300	NU2312	NJ	NUP	–	–	2.69
	150	35	2.1	2.1	83	127	178	184	4 200	5 700	NU412	NJ	NUP	N	NF	3.02
65	100	18	1.1	1	74.5	–	43.3	52.9	6 600	7 800	NU1013	–	–	–	–	0.506
	120	23	1.5	1.5	79.6	105.6	83.8	94.4	5 400	6 400	NU213	NJ	NUP	N	NF	1.05
	120	31	1.5	1.5	79.6	–	120	149	4 800	6 400	NU2213	NJ	NUP	–	–	1.43
	120	38.1	1.5	1.5	79.6	–	148	197	4 300	6 400	NU3213	–	–	–	–	1.90
	140	33	2.1	2.1	83.5	121.5	137	139	4 300	5 800	NU313	NJ	NUP	N	NF	2.24
	140	48	2.1	2.1	83.5	–	190	212	3 900	5 800	NU2313	NJ	NUP	–	–	3.25
	160	37	2.1	2.1	89.3	135.3	198	203	4 000	5 300	NU413	NJ	NUP	–	NF	3.58
	110	20	1.1	1	80	–	57.9	70.4	6 100	7 200	NU1014	–	–	–	–	0.702
	125	24	1.5	1.5	84.5	110.5	83.3	95.2	5 100	6 100	NU214	NJ	NUP	N	NF	1.15
	125	31	1.5	1.5	84.5	–	119	151	4 600	6 100	NU2214	NJ	NUP	–	–	1.52
70	150	35	2.1	2.1	90	130	162	168	4 000	5 400	NU314	NJ	NUP	N	NF	2.73
	150	51	2.1	2.1	90	–	224	262	3 600	5 400	NU2314	NJ	NUP	–	–	3.97
	180	42	3	3	100	152	246	257	3 500	4 700	NU414	NJ	NUP	N	NF	5.26
	115	20	1.1	1	85	–	63.6	78.1	5 700	6 800	NU1015	–	–	–	–	0.735
	130	25	1.5	1.5	88.5	116.5	101	118	4 800	5 800	NU215	NJ	NUP	N	NF	1.24
	130	31	1.5	1.5	88.5	–	135	172	4 300	5 800	NU2215	NJ	NUP	–	–	1.57
75	160	37	2.1	2.1	95.5	139.5	194	205	3 800	5 000	NU315	NJ	NUP	N	NF	3.24
	160	55	2.1	2.1	95.5	–	275	327	3 400	5 000	NU2315	NJ	NUP	–	–	4.84
	190	45	3	3	104.5	160.5	265	274	3 300	4 400	NU415	NJ	NUP	N	NF	6.25
	125	22	1.1	1	91.5	–	69.3	86.4	5 300	6 300	NU1016	–	–	–	–	0.994
	140	26	2	2	95.3	125.3	106	122	4 500	5 400	NU216	NJ	NUP	N	NF	1.51
	140	33	2	2	95.3	–	148	186	4 000	5 400	NU2216	NJ	NUP	–	–	1.96
80	170	39	2.1	2.1	103	147	194	207	3 500	4 700	NU316	NJ	NUP	N	NF	3.92
	170	58	2.1	2.1	103	–	275	332	3 100	4 700	NU2316	NJ	NUP	–	–	5.83
	200	48	3	3	110	170	302	315	3 100	4 200	NU416	NJ	NUP	N	NF	7.28

Remarks) Standard cage types used for the above bearings are shown in Table 1 earlier in this section. Please note that basic load ratings and rotation speed limits shown above indicate the value applicable to machined cage. When bearings with pressed cage are used, consult Koyo.

Cylindrical roller bearings

d 85 – (120) mm

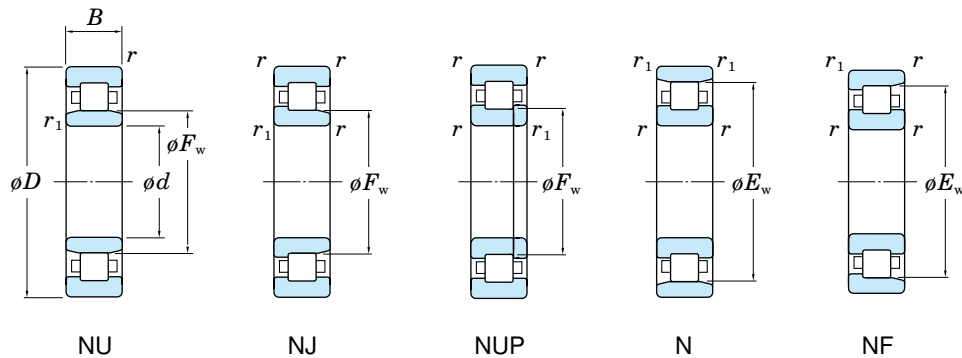

Boundary dimensions (mm)							Basic load ratings (kN)		Limiting speeds (min ⁻¹)		Bearing No.					(Refer.) Mass NU (kg)
d	D	B	$r_{\min.}$	$r_{1\min.}$	F_w	E_w	C_r	C_{0r}	Grease lub.	Oil lub.	NU	NJ	NUP	N	NF	
85	130	22	1.1	1	96.5	–	71.4	91.2	5 100	6 000	NU1017	–	–	–	–	1.04
	150	28	2	2	101.8	133.8	121	140	4 200	5 000	NU217	NJ	NUP	N	NF	1.90
	150	36	2	2	101.8	–	169	218	3 800	5 000	NU2217	NJ	NUP	–	–	2.50
	180	41	3	3	108	156	225	247	3 300	4 500	NU317	NJ	NUP	N	NF	4.52
	180	60	3	3	108	–	315	382	3 000	4 500	NU2317	NJ	NUP	–	–	6.62
210	52	4	4	113	177	340	350	3 000	4 000	NU417	NJ	NUP	N	NF	8.68	
90	160	30	2	2	107	143	152	178	3 900	4 700	NU218	NJ	NUP	N	NF	2.28
	160	40	2	2	107	–	207	265	3 500	4 700	NU2218	NJ	NUP	–	–	3.10
	190	43	3	3	115	165	243	265	3 100	4 200	NU318	NJ	NUP	N	NF	5.38
	190	64	3	3	115	–	329	395	2 800	4 200	NU2318	NJ	NUP	–	–	7.90
	225	54	4	4	123.5	191.5	374	400	2 800	3 700	NU418	NJ	NUP	N	NF	10.3
95	170	32	2.1	2.1	113.5	151.5	165	195	3 700	4 400	NU219	NJ	NUP	N	NF	2.80
	170	43	2.1	2.1	113.5	–	230	298	3 300	4 400	NU2219	NJ	NUP	–	–	3.85
	200	45	3	3	121.5	173.5	277	311	3 000	4 000	NU319	NJ	NUP	N	NF	6.20
	200	67	3	3	121.5	–	394	496	2 600	4 000	NU2319	NJ	NUP	–	–	9.39
	240	55	4	4	133.5	–	410	444	2 600	3 400	NU419	NJ	–	–	–	13.6
100	180	34	2.1	2.1	120	160	183	217	3 500	4 200	NU220	NJ	NUP	N	NF	3.38
	180	46	2.1	2.1	120	–	259	338	3 100	4 200	NU2220	NJ	NUP	–	–	4.67
	215	47	3	3	129.5	185.5	323	337	2 800	3 700	NU320	NJ	NUP	N	NF	7.70
	215	73	3	3	129.5	–	464	548	2 500	3 700	NU2320	NJ	NUP	–	–	11.9
	250	58	4	4	139	–	458	498	2 500	3 300	NU420	NJ	–	–	–	14.0
105	190	36	2.1	2.1	126.8	168.8	201	241	3 300	3 900	NU221	NJ	NUP	N	NF	4.00
	225	49	3	3	135	195	366	417	2 600	3 500	NU321	NJ	NUP	N	NF	8.76
110	200	38	2.1	2.1	132.5	178.5	241	290	3 100	3 700	NU222	NJ	NUP	N	NF	4.65
	200	53	2.1	2.1	132.5	–	334	442	2 800	3 700	NU2222	NJ	NUP	–	–	6.93
	240	50	3	3	143	207	411	467	2 500	3 300	NU322	NJ	NUP	N	NF	10.4
	240	80	3	3	143	–	604	789	2 200	3 300	NU2322	NJ	–	–	–	18.8
	280	65	4	4	155	–	550	621	2 200	2 900	NU422	NJ	–	–	–	19.9
120	215	40	2.1	2.1	143.5	191.5	260	318	2 900	3 400	NU224	NJ	NUP	N	NF	5.65
	215	58	2.1	2.1	143.5	–	367	492	2 600	3 400	NU2224	NJ	NUP	–	–	8.56

Remarks) Standard cage types used for the above bearings are shown in Table 1 earlier in this section. Please note that basic load ratings and rotation speed limits shown above indicate the value applicable to machined cage. When bearings with pressed cage are used, consult Koyo.

d (120) – 200 mm

d	Boundary dimensions (mm)						Basic load ratings (kN)		Limiting speeds (min ⁻¹)		Bearing No.					(Refer.) Mass NU (kg)
	D	B	r min.	r_1 min.	F_w	E_w	C_r	C_{0r}	Grease lub.	Oil lub.	NU	NJ	NUP	N	NF	
120	260	55	3	3	154	226	485	551	2 200	3 000	NU324	NJ	NUP	N	NF	13.1
	260	86	3	3	154	—	708	918	2 000	3 000	NU2324	NJ	NUP	—	—	23.1
	310	72	5	5	170	—	690	770	1 900	2 600	NU424	NJ	—	—	—	28.0
130	200	33	2	1.1	148	—	171	238	3 200	3 800	NU1026	—	—	—	—	3.77
	230	40	3	3	156	204	282	362	2 700	3 200	NU226	NJ	NUP	N	NF	6.49
	230	64	3	3	156	—	395	560	2 400	3 200	NU2226	NJ	NUP	—	—	11.2
	280	58	4	4	167	243	564	667	2 100	2 700	NU326	NJ	NUP	N	NF	16.4
	280	93	4	4	167	—	838	1 130	1 800	2 700	NU2326	NJ	NUP	—	—	29.1
	340	78	5	5	185	—	771	876	1 800	2 300	NU426	NJ	—	—	—	36.1
140	210	33	2	1.1	158	—	175	250	3 000	3 600	NU1028	—	—	—	—	4.00
	250	42	3	3	169	221	324	421	2 400	2 900	NU228	NJ	NUP	N	—	8.27
	250	68	3	3	169	—	465	671	2 200	2 900	NU2228	NJ	NUP	—	—	14.3
	300	62	4	4	180	260	623	746	1 900	2 500	NU328	NJ	NUP	N	NF	20.1
	300	102	4	4	180	—	920	1 250	1 700	2 500	NU2328	NJ	NUP	—	—	36.8
	360	82	5	5	198	—	874	1 020	1 600	2 200	NU428	NJ	—	—	—	46.8
150	225	35	2.1	1.5	169.5	—	201	281	2 800	3 300	NU1030	—	—	—	—	4.83
	270	45	3	3	182	238	374	492	2 200	2 700	NU230	NJ	NUP	N	NF	10.3
	270	73	3	3	182	—	545	800	2 000	2 700	NU2230	NJ	NUP	—	—	18.7
	320	65	4	4	193	277	663	807	1 800	2 300	NU330	NJ	NUP	N	NF	26.4
	320	108	4	4	193	—	1 020	1 400	1 600	2 300	NU2330	NJ	NUP	—	—	44.7
	380	85	5	5	213	—	930	1 120	1 500	2 000	NU430	NJ	—	—	—	53.3
160	290	48	3	3	195	255	427	568	2 100	2 500	NU232	NJ	NUP	N	NF	14.4
	290	80	3	3	195	—	631	939	1 800	2 500	NU2232	NJ	NUP	—	—	23.6
	340	68	4	4	208	292	698	876	1 600	2 200	NU332	NJ	NUP	N	—	31.7
	340	114	4	4	208	—	1 070	1 520	1 400	2 200	NU2332	NJ	NUP	—	—	53.1
170	310	52	4	4	208	272	475	637	1 900	2 300	NU234	NJ	NUP	N	—	18.4
	310	86	4	4	208	—	715	1 080	1 700	2 300	NU2234	NJ	NUP	—	—	29.2
	360	72	4	4	220	310	809	1 010	1 500	2 000	NU334	NJ	NUP	N	—	38.6
	360	120	4	4	220	—	1 220	1 750	1 300	2 000	NU2334	NJ	NUP	—	—	62.6
180	320	52	4	4	218	282	492	677	1 800	2 200	NU236	NJ	NUP	N	—	19.3
	320	86	4	4	218	—	741	1 140	1 600	2 200	NU2236	NJ	NUP	—	—	30.4
	380	75	4	4	232	328	917	1 150	1 400	1 900	NU336	NJ	NUP	N	—	42.6
	380	126	4	4	232	—	1 350	1 940	1 300	1 900	NU2336	NJ	NUP	—	—	73.0
190	340	55	4	4	231	299	554	768	1 700	2 000	NU238	NJ	NUP	N	—	23.2
	340	92	4	4	231	—	828	1 290	1 500	2 000	NU2238	NJ	NUP	—	—	37.0
	400	78	5	5	245	345	987	1 260	1 300	1 800	NU338	NJ	NUP	N	—	49.9
	400	132	5	5	245	—	1 520	2 220	1 200	1 800	NU2338	NJ	NUP	—	—	84.7
200	360	58	4	4	244	316	618	865	1 600	1 900	NU240	NJ	NUP	N	—	26.8
	360	98	4	4	244	—	946	1 490	1 400	1 900	NU2240	NJ	NUP	—	—	44.4
	420	80	5	5	260	360	987	1 270	1 200	1 700	NU340	NJ	NUP	N	—	56.2
	420	138	5	5	260	—	1 520	2 240	1 100	1 700	NU2340	NJ	NUP	—	—	97.4

Remarks) Standard cage types used for the above bearings are shown in Table 1 earlier in this section. Please note that basic load ratings and rotation speed limits shown above indicate the value applicable to machined cage. When bearings with pressed cage are used, consult Koyo.

KOYO

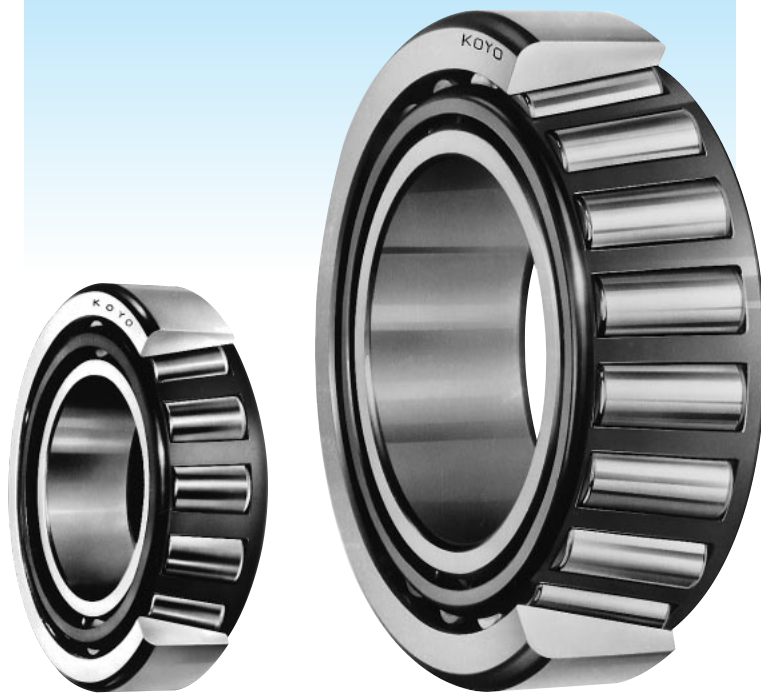

Tapered roller bearings

Tapered roller bearings are designed such that cup, cone and rollers have tapered surfaces whose apexes converge at a common point on the bearing axis.

Along with metric series bearings, inch series bearings are also available.

This type of bearing is suitable for applications that involve heavy or impact loading.

■ Tapered roller bearings

- Able to carry radial and axial load in one direction simultaneously.

Because an axial component of force is produced when this type of bearing is loaded radially, two bearings are used together facing one another, or two or more bearings are matched and used.

- There are the standard, medium and steep type which are different in contact angle size.

Medium-tapered metric series bearings are identified by the supplementary code "C" which is added as a suffix to bearing numbers.

- Bearings whose cup width, cup small inside diameter and contact angle are determined in accordance with ISO 355 specifications are identified by the supplementary code "J" as a suffix.

Cone assemblies and the cups of such bearings are inter-changeable with those of bearings produced abroad if the bearing numbers are the same.

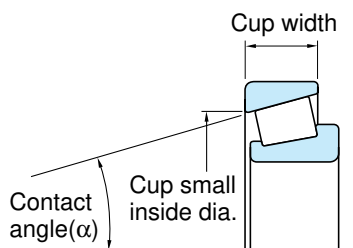

ISO sub-unit specifications

Note : When supplementary code "J" is added as a prefix (not a suffix) to bearing numbers (e.g. JHM720249/JHM720210), the bearings are not designed according to ISO 355. Such bearings are called "J series metric tapered roller bearings," and are produced according to special tolerances.

Tapered roller bearings

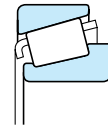

Metric series

Bore diameter **15 – 200 mm**

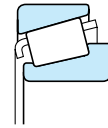

Inch series

(including J series metric bearing)

Bore diameter **15.875 – 200.000 mm**

Tapered roller bearings

Boundary dimensions	<p>Metric single-row tapered roller bearings : as specified in JIS B 1512.</p> <p>Reference JIS B 1512 specifies new dimension series which are based on ISO 355, as well as the conventional "3XX" dimension series. These new dimension series are as follows :</p> <p>New dimension series</p> <p>(1) Angle series</p> <table border="1" data-bbox="485 539 919 792"> <thead> <tr> <th rowspan="2">Angle series</th> <th colspan="2">Contact angle α</th> </tr> <tr> <th>over</th> <th>up to</th> </tr> </thead> <tbody> <tr> <td>2</td> <td>10°</td> <td>13°52'</td> </tr> <tr> <td>3</td> <td>13°52'</td> <td>15°59'</td> </tr> <tr> <td>4</td> <td>15°59'</td> <td>18°55'</td> </tr> <tr> <td>5</td> <td>18°55'</td> <td>23°</td> </tr> <tr> <td>6</td> <td>23°</td> <td>27°</td> </tr> <tr> <td>7</td> <td>27°</td> <td>30°</td> </tr> </tbody> </table> <p>(2) Diameter series</p> <table border="1" data-bbox="485 869 919 1122"> <thead> <tr> <th rowspan="2">Diameter series</th> <th colspan="2">$D/ (d^{0.77})$</th> </tr> <tr> <th>over</th> <th>up to</th> </tr> </thead> <tbody> <tr> <td>B</td> <td>3.40</td> <td>3.80</td> </tr> <tr> <td>C</td> <td>3.80</td> <td>4.40</td> </tr> <tr> <td>D</td> <td>4.40</td> <td>4.70</td> </tr> <tr> <td>E</td> <td>4.70</td> <td>5.00</td> </tr> <tr> <td>F</td> <td>5.00</td> <td>5.60</td> </tr> <tr> <td>G</td> <td>5.60</td> <td>7.00</td> </tr> </tbody> </table> <p>(3) Width series</p> <table border="1" data-bbox="987 539 1422 741"> <thead> <tr> <th rowspan="2">Width series</th> <th colspan="2">$T/ \{(D-d)^{0.95}\}$</th> </tr> <tr> <th>over</th> <th>up to</th> </tr> </thead> <tbody> <tr> <td>B</td> <td>0.50</td> <td>0.68</td> </tr> <tr> <td>C</td> <td>0.68</td> <td>0.80</td> </tr> <tr> <td>D</td> <td>0.80</td> <td>0.88</td> </tr> <tr> <td>E</td> <td>0.88</td> <td>1.00</td> </tr> </tbody> </table> <p>Remarks :</p> <ol style="list-style-type: none"> Combine these series symbols in the listed order to make the dimension series numbers. (ex. 2BC) Bearing numbers consist of a dimension series number and a bore diameter which is added as a suffix. (ex. 2BC080 : bearing bore diameter 80 mm) 	Angle series	Contact angle α		over	up to	2	10°	13°52'	3	13°52'	15°59'	4	15°59'	18°55'	5	18°55'	23°	6	23°	27°	7	27°	30°	Diameter series	$D/ (d^{0.77})$		over	up to	B	3.40	3.80	C	3.80	4.40	D	4.40	4.70	E	4.70	5.00	F	5.00	5.60	G	5.60	7.00	Width series	$T/ \{(D-d)^{0.95}\}$		over	up to	B	0.50	0.68	C	0.68	0.80	D	0.80	0.88	E	0.88	1.00
Angle series	Contact angle α																																																															
	over	up to																																																														
2	10°	13°52'																																																														
3	13°52'	15°59'																																																														
4	15°59'	18°55'																																																														
5	18°55'	23°																																																														
6	23°	27°																																																														
7	27°	30°																																																														
Diameter series	$D/ (d^{0.77})$																																																															
	over	up to																																																														
B	3.40	3.80																																																														
C	3.80	4.40																																																														
D	4.40	4.70																																																														
E	4.70	5.00																																																														
F	5.00	5.60																																																														
G	5.60	7.00																																																														
Width series	$T/ \{(D-d)^{0.95}\}$																																																															
	over	up to																																																														
B	0.50	0.68																																																														
C	0.68	0.80																																																														
D	0.80	0.88																																																														
E	0.88	1.00																																																														
Tolerances	<ul style="list-style-type: none"> • Metric series single-row tapered roller bearings as specified in JIS B 1514. • Inch series tapered roller bearings as specified in ABMA Section 19. • J series metric tapered roller bearings the tolerance is specified separately. 																																																															
Standard cage	<p>Pressed steel cage (supplementary code : //) (Some large size bearings have a pin type cage (FP) instead.)</p>																																																															
Allowable misalignment	<p>Single-row tapered roller bearings : 0.000 9 rad (3') (If the misalignment exceeds this angle size, Koyo is ready to design special bearings to order.)</p>																																																															

Equivalent radial load	<ul style="list-style-type: none"> ■ Single-row tapered roller bearings
	Dynamic equivalent radial load $\left[\text{when } \frac{F_a}{F_r} \leq e \right] P_r = F_r$ $\left[\text{when } \frac{F_a}{F_r} > e \right] P_r = 0.4F_r + Y_1 F_a$
	Static equivalent radial load $P_{0r} = 0.5F_r + Y_0 F_a$ when $P_{0r} < F_r$, $P_{0r} = F_r$
	<ul style="list-style-type: none"> ■ Double-row or four-row tapered roller bearings
	Dynamic equivalent radial load $\left[\text{when } \frac{F_a}{F_r} \leq e \right] P_r = F_r + Y_2 F_a$ $\left[\text{when } \frac{F_a}{F_r} > e \right] P_r = 0.67F_r + Y_3 F_a$
	Static equivalent radial load $P_{0r} = F_r + Y_0 F_a$

- Remarks) 1. When two single-row tapered roller bearings are used together facing one another, an axial component of force is produced under radial load.
2. When the load is too small, slippage occurs between the rollers and raceways, causing smearing to develop. This also occurs to matched pair bearings when the ratio of axial load to radial load exceeds the value e shown in the specification table ($F_a / F_r > e$).
- Consult Koyo on use of bearings under such conditions.

Tapered roller bearings metric series

d 15 – 30 mm

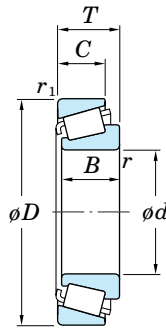

d	Boundary dimensions (mm)						Basic load ratings (kN)		Limiting speeds (min ⁻¹)		Bearing No.	(Refer.) Dimension series to ISO355	(Refer.) Mass (kg)
	D	T	B	C	r min.	r_1 min.	C_r	C_{or}	Grease lub.	Oil lub.			
15	35	11.75	11	10	0.6	0.6	15.8	14.5	12 000	16 000	30202R 30302JR	–	0.054
	42	14.25	13	11	1	1	21.9	19.2	10 000	14 000		2FB	0.098
17	40	13.25	12	11	1	1	20.8	20.7	10 000	14 000	30203JR 32203JR 30303R	2DB	0.081
	40	17.25	16	14	1	1	27.4	27.5	10 000	14 000		2DD	0.104
	47	15.25	14	12	1	1	27.4	24.5	9 200	12 000		–	0.127
20	47	20.25	19	16	1	1	31.9	29.9	9 400	13 000	32303	–	0.170
	42	15	15	12	0.6	0.6	27.3	31.5	9 700	13 000	32004JR 57008R 30204JR	3CC	0.102
	47	15.25	14	12	1	1	25.8	25.5	9 000	12 000		–	0.125
	47	15.25	14	12	1	1	27.0	27.2	8 700	12 000		2DB	0.127
	47	19.25	18	15	1	1	33.1	34.7	8 900	12 000	32204JR	2DD	0.159
	52	16.25	16	13	1.5	1.5	36.2	35.1	8 300	11 000	30304AJR	–	0.179
52	22.25	21	18	1.5	1.5	45.1	46.7	8 400	11 000	32304JR	2FD	0.244	
22	44	15	15	11.5	0.6	0.6	28.3	33.6	9 100	12 000	320/22JR	3CC	0.108
25	47	15	15	11.5	0.6	0.6	30.2	37.7	8 300	11 000	32005JR	4CC	0.118
	47	17	17	14	0.6	0.6	33.5	42.3	8 300	11 000	33005JR	2CE	0.131
	52	16.25	15	13	1	1	31.5	33.7	7 800	10 000	30205JR	3CC	0.156
	52	19.25	18	16	1	1	39.8	44.8	7 900	11 000	32205JR	2CD	0.188
	52	22	22	18	1	1	48.9	58.5	7 900	10 000	33205JR	2DE	0.225
	62	18.25	17	13	1.5	1.5	39.8	42.5	5 700	8 000	30305DJR	7FB	0.269
28	62	18.25	17	14	1.5	1.5	45.0	45.8	6 700	9 000	TR0506R	–	0.275
	62	18.25	17	15	1.5	1.5	48.2	46.9	6 800	9 000	30305JR	2FB	0.273
	62	25.25	24	20	1.5	1.5	61.2	64.1	6 900	9 100	32305JR	2FD	0.386
	52	16	16	12	1	1	35.2	44.0	7 500	10 000	320/28JR	4CC	0.150
30	55	17	17	13	1	1	38.2	48.0	7 000	9 400	32006JR	4CC	0.177
	55	20	20	16	1	1	43.2	55.2	7 000	9 400	33006JR	2CE	0.203
	62	17.25	16	14	1	1	41.5	44.8	6 500	8 700	30206JR	3DB	0.236
	62	21.25	20	17	1	1	50.7	57.9	6 500	8 700	32206JR	3DC	0.292
	62	25	25	19.5	1	1	66.4	79.4	6 500	8 700	33206JR	2DE	0.359
	72	20.75	19	14	1.5	1.5	50.9	54.9	4 900	6 800	30306DJR	7FB	0.400
	72	20.75	19	16	1.5	1.5	56.5	55.2	5 900	7 900	TRA0607R	–	0.405
	72	20.75	19	16	1.5	1.5	59.6	60.1	5 800	7 700	30306JR	2FB	0.411
72	28.75	27	23	1.5	1.5	82.2	91.6	5 900	7 900	32306JR	2FD	0.588	

d 32 – (55) mm

d	Boundary dimensions (mm)						Basic load ratings (kN)		Limiting speeds (min ⁻¹)		Bearing No.	(Refer.) Dimension series to ISO355	(Refer.) Mass (kg)
	D	T	B	C	r min.	r_1 min.	C_r	C_{or}	Grease lub.	Oil lub.			
32	58	17	17	13	1	1	39.2	50.6	6 700	8 900	320/32JR	4CC	0.196
	65	22.25	21	18	1	1	51.6	57.7	6 200	8 200	322/32	—	0.330
	75	29.75	28	23	1.5	1.5	75.1	87.1	5 600	7 400	TR0608A	5FD	0.649
35	62	18	18	14	1	1	45.5	59.4	6 200	8 200	32007JR	4CC	0.231
	62	21	21	17	1	1	51.3	68.0	6 200	8 200	33007JR	2CE	0.263
	72	18.25	17	15	1.5	1.5	55.1	60.9	5 600	7 400	30207JR	3DB	0.344
	72	24.25	23	19	1.5	1.5	69.6	82.4	5 600	7 500	32207JR	3DC	0.453
	72	28	28	22	1.5	1.5	87.6	107	5 700	7 500	33207JR	2DE	0.551
	80	22.75	21	15	2	1.5	63.1	69.1	4 300	6 000	30307DJR	7FB	0.536
	80	22.75	21	18	2	1.5	76.2	78.9	5 200	6 900	30307JR-1	2FB	0.527
	80	32.75	31	25	2	1.5	96.9	123	5 200	7 000	TR0708-1R	—	0.830
	80	32.75	31	25	2	1.5	101	114	5 300	7 000	32307JR	2FE	0.776
	40	68	19	19	14.5	1	1	53.5	71.4	5 600	7 400	32008JR	3CD
68		22	22	18	1	1	60.4	84.6	5 500	7 400	33008JR	2BE	0.326
75		26	26	20.5	1.5	1.5	82.2	108	5 200	6 900	33108JR	2CE	0.508
80		19.75	18	16	1.5	1.5	62.9	69.2	5 000	6 700	30208JR	3DB	0.434
80		24.75	23	19	1.5	1.5	77.7	90.8	5 000	6 600	32208JR	3DC	0.554
80		32	32	25	1.5	1.5	108	139	5 000	6 700	33208JR	2DE	0.758
90		25.25	23	17	2	1.5	80.5	90.2	3 800	5 300	30308DJR	7FB	0.757
90		25.25	23	20	2	1.5	90.6	101	4 500	6 100	30308JR	2FB	0.757
90		35.25	33	26	2	1.5	112	138	4 700	6 200	TR0809AR	—	1.10
90		35.25	33	27	2	1.5	116	139	4 600	6 200	32308JR	2FD	1.06
45	75	20	20	15.5	1	1	62.8	86.5	5 000	6 600	32009JR	3CC	0.354
	75	24	24	19	1	1	69.6	101	5 000	6 700	33009JR	2CE	0.416
	80	26	26	20.5	1.5	1.5	87.5	120	4 800	6 400	33109JR	3CE	0.563
	85	20.75	19	16	1.5	1.5	67.2	77.4	4 600	6 100	30209JR	3DB	0.502
	85	24.75	23	19	1.5	1.5	84.2	104	4 600	6 100	32209JR-1	3DC	0.597
	85	32	32	25	1.5	1.5	112	149	4 600	6 200	33209JR	3DE	0.818
	100	27.25	25	18	2	1.5	95.1	107	3 400	4 700	30309DJR	7FB	0.973
	100	27.25	25	22	2	1.5	113	128	4 100	5 400	30309JR	2FB	1.01
	100	38.25	36	30	2	1.5	146	180	4 100	5 500	32309JR	2FD	1.43
	50	72	15	15	12	0.6	0.6	35.9	56.3	4 900	6 600	32910JR	2BC
80		20	20	15.5	1	1	65.7	94.5	4 600	6 100	32010JR	3CC	0.389
80		24	24	19	1	1	73.0	110	4 600	6 100	33010JR	2CE	0.451
85		26	26	20	1.5	1.5	89.4	127	4 400	5 900	33110JR	3CE	0.594
90		21.75	20	17	1.5	1.5	76.5	91.7	4 300	5 700	30210JR	3DB	0.566
90		24.75	23	19	1.5	1.5	85.0	105	4 300	5 700	32210JR	3DC	0.643
90		32	32	24.5	1.5	1.5	119	167	4 300	5 700	33210JR	3DE	0.887
110		29.25	27	19	2.5	2	115	133	3 100	4 300	30310DJR	7FB	1.25
110		29.25	27	23	2.5	2	137	152	3 700	4 900	30310JR	2FB	1.32
110		42.25	40	33	2.5	2	176	220	3 700	5 000	32310JR	2FD	1.89
55	80	17	17	14	1	1	44.6	73.3	4 400	5 900	32911JR	2BC	0.285
	90	23	23	17.5	1.5	1.5	84.6	121	4 100	5 500	32011JR	3CC	0.569
	90	27	27	21	1.5	1.5	96.5	149	4 100	5 400	33011JR	2CE	0.672
	95	30	30	23	1.5	1.5	116	161	4 000	5 300	33111JR	3CE	0.868
	100	22.75	21	18	2	1.5	94.6	113	3 900	5 200	30211JR	3DB	0.732
	100	26.75	25	21	2	1.5	107	133	3 900	5 200	32211JR-1	3DC	0.863
	100	35	35	27	2	1.5	142	189	3 900	5 200	33211JR	3DE	1.18
	120	31.5	29	21	2.5	2	129	148	2 900	4 000	30311DJR	7FB	1.59

Tapered roller bearings metric series

d (55) – 70 mm

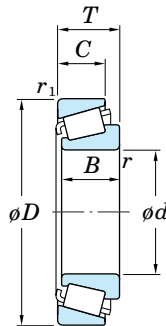

d	Boundary dimensions (mm)						Basic load ratings (kN)		Limiting speeds (min ⁻¹)		Bearing No.	(Refer.) Dimension series to ISO355	(Refer.) Mass (kg)
	D	T	B	C	r min.	r_1 min.	C_r	C_{or}	Grease lub.	Oil lub.			
55	120	31.5	29	25	2.5	2	149	170	3 300	4 500	30311JR 32311JR	2FB	1.65
	120	45.5	43	35	2.5	2	200	250	3 400	4 500		2FD	2.38
60	85	17	17	14	1	1	46.2	78.2	4 100	5 500	32912JR 32012JR 33012JR	2BC	0.306
	95	23	23	17.5	1.5	1.5	86.1	127	3 900	5 200		4CC	0.621
	95	27	27	21	1.5	1.5	101	162	3 900	5 200		2CE	0.719
	100	30	30	23	1.5	1.5	118	170	3 700	5 000	33112JR 30212JR	3CE	0.923
	110	23.75	22	19	2	1.5	106	127	3 500	4 700		3EB	0.945
	110	29.75	28	24	2	1.5	132	167	3 500	4 700	32212JR	3EC	1.19
	110	38	38	29	2	1.5	174	239	3 600	4 700	33212JR 30312DJR	3EE	1.57
	130	33.5	31	22	3	2.5	153	179	2 600	3 700		7FB	2.01
	130	33.5	31	26	3	2.5	173	201	3 100	4 100	30312JR	2FB	2.08
	130	48.5	46	37	3	2.5	244	315	3 100	4 200	32312JR	2FD	2.99
65	90	17	17	14	1	1	47.4	83.1	3 900	5 200	32913JR 32013JR 33013JR	2BC	0.327
	100	23	23	17.5	1.5	1.5	90.0	137	3 600	4 800		4CC	0.664
	100	27	27	21	1.5	1.5	103	169	3 600	4 800		2CE	0.762
	110	34	34	26.5	1.5	1.5	152	223	3 400	4 600	33113JR 30213JR	3DE	1.33
	120	24.75	23	20	2	1.5	128	156	3 200	4 300		3EB	1.18
	120	32.75	31	27	2	1.5	157	203	3 200	4 300	32213JR	3EC	1.58
	120	41	41	32	2	1.5	200	277	3 200	4 300	33213JR 30313DJR	3EE	2.02
	140	36	33	23	3	2.5	176	209	2 400	3 400		7GB	2.44
	140	36	33	28	3	2.5	204	239	2 800	3 800	30313JR	2GB	2.56
	140	51	48	39	3	2.5	276	357	2 900	3 900	32313JR	2GD	3.64
70	100	20	20	16	1	1	71.0	115	3 500	4 700	32914JR 32014JR 33014JR	2BC	0.496
	110	25	25	19	1.5	1.5	108	163	3 300	4 400		4CC	0.884
	110	31	31	25.5	1.5	1.5	134	208	3 300	4 400		2CE	1.09
	120	37	37	29	2	1.5	181	266	3 100	4 200	33114JR 30214JR	3DE	1.71
	125	26.25	24	21	2	1.5	138	173	3 100	4 100		3EB	1.32
	125	33.25	31	27	2	1.5	169	225	3 100	4 100	32214JR	3EC	1.71
	125	41	41	32	2	1.5	206	294	3 100	4 100	33214JR 30314DJR	3EE	2.16
	150	38	35	25	3	2.5	197	235	2 300	3 200		7GB	2.97
	150	38	35	30	3	2.5	230	273	2 600	3 500	30314JR	2GB	3.08
	150	54	51	42	3	2.5	317	414	2 700	3 600	32314JR	2GD	4.50

d 75 – 95 mm

<i>d</i>	Boundary dimensions (mm)						Basic load ratings (kN)		Limiting speeds (min ⁻¹)		Bearing No.	(Refer.) Dimension series to ISO355	(Refer.) Mass (kg)	
	<i>D</i>	<i>T</i>	<i>B</i>	<i>C</i>	<i>r</i> min.	<i>r</i> ₁ min.	<i>C</i> _r	<i>C</i> _{0r}	Grease lub.	Oil lub.				
75	105	20	20	16	1	1	73.6	123	3 300	4 400	32915JR	2BC	0.526	
	115	25	25	19	1.5	1.5	110	169	3 100	4 200	32015JR	4CC	0.930	
	115	31	31	25.5	1.5	1.5	141	225	3 200	4 200	33015JR	2CE	1.16	
	125	37	37	29	2	1.5	186	280	3 000	4 000	33115JR	3DE	1.84	
	130	27.25	25	22	2	1.5	142	181	2 900	3 900	30215JR	4DB	1.42	
	130	33.25	31	27	2	1.5	174	234	2 900	3 900	32215JR	4DC	1.77	
	130	41	41	31	2	1.5	212	310	2 900	3 900	33215JR	3EE	2.26	
	160	40	37	26	3	2.5	222	266	2 100	2 900	30315DR	–	3.48	
	160	40	37	31	3	2.5	260	311	2 500	3 300	30315JR	2GB	3.65	
	160	58	55	45	3	2.5	363	481	2 500	3 300	32315JR	2GD	5.41	
	80	110	20	20	16	1	1	76.1	131	3 100	4 200	32916JR	2BC	0.556
		125	29	29	22	1.5	1.5	147	225	2 900	3 900	32016JR	3CC	1.32
125		36	36	29.5	1.5	1.5	173	288	2 900	3 900	33016JR	2CE	1.63	
130		37	37	29	2	1.5	191	294	2 800	3 800	33116JR	3DE	1.93	
140		28.25	26	22	2.5	2	161	202	2 700	3 600	30216JR	3EB	1.72	
140		35.25	33	28	2.5	2	203	271	2 700	3 600	32216JR	3EC	2.17	
140		46	46	35	2.5	2	250	371	2 700	3 600	33216JR	3EE	2.99	
170		42.5	39	27	3	2.5	236	282	2 000	2 800	30316DJR	7GB	4.12	
170		42.5	39	33	3	2.5	294	355	2 300	3 100	30316JR	2GB	4.46	
170		61.5	58	48	3	2.5	383	503	2 300	3 100	32316JR	2GD	6.31	
85		120	23	23	18	1.5	1.5	97.1	165	2 900	3 900	32917JR	2BC	0.794
		130	29	29	22	1.5	1.5	150	234	2 800	3 700	32017JR	4CC	1.38
	130	36	36	29.5	1.5	1.5	177	300	2 800	3 700	33017JR	2CE	1.72	
	140	41	41	32	2.5	2	224	346	2 600	3 500	33117JR	3DE	2.43	
	150	30.5	28	24	2.5	2	182	231	2 500	3 400	30217JR	3EB	2.17	
	150	38.5	36	30	2.5	2	232	315	2 500	3 400	32217JR	3EC	2.80	
	150	49	49	37	2.5	2	294	439	2 500	3 400	33217JR	3EE	3.63	
	180	44.5	41	28	4	3	263	317	1 900	2 600	30317DJR	7GB	4.81	
	180	44.5	41	34	4	3	316	384	2 200	2 900	30317JR	2GB	5.15	
	180	63.5	60	49	4	3	439	587	2 200	3 000	32317JR	2GD	7.42	
	90	125	23	23	18	1.5	1.5	101	175	2 800	3 700	32918JR	2BC	0.834
		140	32	32	24	2	1.5	178	276	2 600	3 500	32018JR	3CC	1.80
140		39	39	32.5	2	1.5	221	367	2 600	3 400	33018JR	2CE	2.22	
150		45	45	35	2.5	2	258	413	2 500	3 300	33118JR	3DE	3.13	
160		32.5	30	26	2.5	2	204	261	2 400	3 200	30218JR	3FB	2.65	
160		42.5	40	34	2.5	2	263	362	2 400	3 200	32218JR	3FC	3.47	
190		46.5	43	30	4	3	282	336	1 700	2 400	30318DR	–	5.60	
190		46.5	43	36	4	3	345	420	2 100	2 700	30318JR	2GB	6.04	
190		67.5	64	53	4	3	461	614	2 100	2 800	32318JR	2GD	8.61	
95		145	32	32	24	2	1.5	182	287	2 500	3 300	32019JR	4CC	1.88
		145	39	39	32.5	2	1.5	226	382	2 500	3 300	33019JR	2CE	2.31
		160	49	49	38	2.5	2	304	473	2 300	3 100	33119JR	3EE	3.89
	170	34.5	32	27	3	2.5	231	299	2 200	3 000	30219JR	3FB	3.20	
	170	45.5	43	37	3	2.5	311	439	2 200	3 000	32219JR	3FC	4.34	
	170	58	58	44	3	2.5	374	582	2 200	2 900	33219JR	3FE	5.66	
	200	49.5	45	32	4	3	319	391	1 700	2 300	30319DJR	7GB	6.68	
	200	49.5	45	38	4	3	372	455	2 000	2 600	30319JR	2GB	6.96	
	200	71.5	67	55	4	3	517	695	2 000	2 600	32319JR	2GD	10.1	

Tapered roller bearings metric series

d 100 – (120) mm

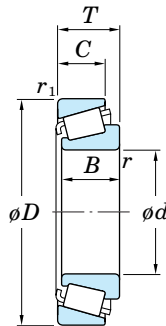

d	Boundary dimensions (mm)						Basic load ratings (kN)		Limiting speeds (min ⁻¹)		Bearing No.	(Refer.) Dimension series to ISO355	(Refer.) Mass (kg)	
	D	T	B	C	r min.	r_1 min.	C_r	C_{or}	Grease lub.	Oil lub.				
100	140	25	25	20	1.5	1.5	126	217	2 400	3 300	32920JR	2CC	1.19	
	150	32	32	24	2	1.5	185	298	2 400	3 200	32020JR	4CC	1.95	
	150	39	39	32.5	2	1.5	231	397	2 400	3 200	33020JR	2CE	2.40	
	165	52	52	40	2.5	2	325	523	2 200	3 000	33120JR	3EE	4.29	
	180	37	34	29	3	2.5	258	338	2 100	2 800	30220JR	3FB	3.83	
	180	49	46	39	3	2.5	347	495	2 100	2 800	32220JR	3FC	5.21	
	180	63	63	48	3	2.5	431	680	2 100	2 800	33220JR	3FE	6.92	
	215	51.5	47	34	4	3	318	374	1 500	2 100	30320D	–	8.02	
	215	51.5	47	39	4	3	344	400	1 800	2 400	30320	–	7.76	
	215	51.5	47	39	4	3	422	521	1 800	2 400	30320JR	2GB	8.49	
	215	56.5	51	35	4	3	373	459	1 500	2 200	31320JR	7GB	8.72	
	215	77.5	73	60	4	3	579	783	1 800	2 400	32320JR	2GD	13.0	
	105	145	25	25	20	1.5	1.5	128	224	2 400	3 100	32921JR	2CC	1.23
		160	35	35	26	2.5	2	215	344	2 200	3 000	32021JR	4DC	2.45
		160	43	43	34	2.5	2	267	461	2 200	3 000	33021JR	2DE	3.08
175		56	56	44	2.5	2	360	607	2 100	2 800	33121JR	3EE	5.33	
190		39	36	30	3	2.5	288	380	2 000	2 600	30221JR	3FB	4.49	
190		53	50	43	3	2.5	392	567	2 000	2 700	32221JR	3FC	6.37	
190		68	68	52	3	2.5	497	790	2 000	2 600	33221JR	3FE	8.43	
225		53.5	49	41	4	3	464	578	1 700	2 300	30321JR	2GB	9.73	
225		58	53	36	4	3	397	489	1 500	2 100	31321JR	7GB	9.72	
225		81.5	77	63	4	3	635	866	1 800	2 300	32321JR	2GD	14.9	
110		170	38	38	29	2.5	2	248	395	2 100	2 800	32022JR	4DC	3.12
		170	47	47	37	2.5	2	287	502	2 100	2 800	33022JR	2DE	3.81
		180	56	56	43	2.5	2	369	634	2 000	2 700	33122JR	3EE	5.52
		200	41	38	32	3	2.5	324	434	1 900	2 500	30222JR	3FB	5.33
		200	56	53	46	3	2.5	438	640	1 900	2 500	32222JR	3FC	7.45
	240	54.5	50	42	4	3	481	590	1 600	2 100	30322JR	2GB	11.4	
	240	63	57	38	4	3	452	563	1 400	1 900	31322JR	7GB	12.2	
	240	84.5	80	65	4	3	691	943	1 600	2 200	32322JR	2GD	17.8	
	120	165	29	29	23	1.5	1.5	172	298	2 100	2 700	32924JR	2CC	1.77
		180	38	38	29	2.5	2	258	427	2 000	2 600	32024JR	4DC	3.34
		180	48	48	38	2.5	2	299	540	2 000	2 600	33024JR	2DE	4.16
		200	62	62	48	2.5	2	462	785	1 800	2 400	33124JR	3FE	7.73
		215	43.5	40	34	3	2.5	347	473	1 700	2 300	30224JR	4FB	6.36

d (120) – 200 mm

d	Boundary dimensions (mm)						Basic load ratings (kN)		Limiting speeds (min ⁻¹)		Bearing No.	(Refer.) Dimension series to ISO355	(Refer.) Mass (kg)
	D	T	B	C	r min.	r_1 min.	C_r	C_{0r}	Grease lub.	Oil lub.			
120	215	61.5	58	50	3	2.5	470	691	1 700	2 300	32224JR	4FD	9.04
	260	59.5	55	46	4	3	569	714	1 500	2 000	30324JR	2GB	14.5
	260	68	62	42	4	3	526	665	1 300	1 800	31324JR	7GB	15.4
	260	90.5	86	69	4	3	800	1 110	1 500	2 000	32324JR	2GD	22.2
130	180	32	32	25	2	1.5	200	368	1 900	2 500	32926JR	2CC	2.42
	200	45	45	34	2.5	2	340	563	1 800	2 300	32026JR	4EC	5.04
	200	55	55	43	2.5	2	390	705	1 700	2 300	33026JR	2EE	6.19
	230	43.75	40	34	4	3	377	511	1 600	2 100	30226JR	4FB	7.24
	230	67.75	64	54	4	3	554	830	1 600	2 200	32226JR	4FD	11.5
	280	63.75	58	49	5	4	657	834	1 400	1 800	30326JR	2GB	18.1
	280	72	66	44	5	4	589	748	1 200	1 600	31326JR	7GB	18.9
140	190	32	32	25	2	1.5	206	390	1 800	2 300	32928JR	2CC	2.57
	210	45	45	34	2.5	2	346	585	1 700	2 200	32028JR	4DC	5.28
	210	56	56	44	2.5	2	406	758	1 600	2 200	33028JR	2DE	6.61
	250	45.75	42	36	4	3	420	570	1 500	1 900	30228JR	4FB	8.97
	250	71.75	68	58	4	3	636	961	1 500	2 000	32228JR	4FD	14.7
	300	67.75	62	53	5	4	749	962	1 300	1 700	30328JR	2GB	22.6
	300	77	70	47	5	4	674	865	1 100	1 500	31328JR	7GB	23.3
150	210	38	38	30	2.5	2	286	536	1 600	2 100	32930JR	2DC	3.96
	225	48	48	36	3	2.5	391	668	1 500	2 000	32030JR	4EC	6.41
	225	59	59	46	3	2.5	459	869	1 500	2 000	33030JR	2EE	8.09
	270	49	45	38	4	3	483	664	1 300	1 800	30230JR	4GB	11.6
	270	77	73	60	4	3	704	1 070	1 300	1 800	32230JR	4GD	18.2
	320	72	65	55	5	4	837	1 080	1 200	1 500	30330JR	2GB	26.6
	320	82	75	50	5	4	763	989	980	1 400	31330JR	7GB	28.0
160	220	38	38	30	2.5	2	295	568	1 500	2 000	32932JR	2DC	4.19
	240	51	51	38	3	2.5	440	758	1 400	1 900	32032JR	4EC	7.75
	290	52	48	40	4	3	542	750	1 200	1 600	30232JR	4GB	14.1
	290	84	80	67	4	3	795	1 210	1 200	1 700	32232JR	4GD	23.2
	340	75	68	58	5	4	938	1 220	1 100	1 400	30332JR	2GB	31.8
170	230	38	38	30	2.5	2	296	606	1 400	1 900	32934JR	3DC	4.49
	260	57	57	43	3	2.5	526	905	1 300	1 700	32034JR	4EC	10.5
	310	57	52	43	5	4	620	867	1 100	1 500	30234JR	4GB	17.8
	310	91	86	71	5	4	898	1 380	1 100	1 500	32234JR	4GD	28.9
	360	80	72	62	5	4	1 040	1 370	1 000	1 300	30334JR	2GB	37.5
180	250	45	45	34	2.5	2	357	735	1 300	1 700	32936JR	4DC	6.64
	280	64	64	48	3	2.5	644	1 100	1 200	1 600	32036JR	3FD	14.1
	320	57	52	43	5	4	615	870	1 100	1 400	30236JR	4GB	18.3
	320	91	86	71	5	4	957	1 520	1 100	1 500	32236JR	4GD	29.9
190	260	45	45	34	2.5	2	366	789	1 200	1 600	32938JR	4DC	6.89
	290	64	64	48	3	2.5	654	1 170	1 100	1 500	32038JR	4FD	14.7
	340	60	55	46	5	4	729	1 030	1 000	1 300	30238JR	4GB	21.9
	340	97	92	75	5	4	1 090	1 740	1 000	1 300	32238JR	4GD	36.6
200	280	51	51	39	3	2.5	486	958	1 100	1 500	32940JR	3EC	9.44
	310	70	70	53	3	2.5	755	1 340	1 100	1 400	32040JR	4FD	19.1
	360	64	58	48	5	4	792	1 120	940	1 200	30240JR	4GB	26.4
	360	104	98	82	5	4	1 240	1 880	960	1 300	32240JR	3GD	44.2

Tapered roller bearings inch series

d 15.875 – (28.575) mm

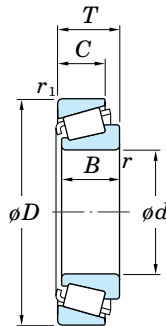

Boundary dimensions (mm)							Basic load ratings (kN)		Limiting speeds (min ⁻¹)		Bearing No.		(Refer.) Mass (kg)	
d	D	T	B	C	r min.	r_1 min.	C_r	C_{0r}	Grease lub.	Oil lub.	Cone	Cup	Cone	Cup
15.875	42.862	14.288	14.288	9.525	1.6	1.6	17.8	17.7	10 000	14 000	11590	11520	0.060	0.040
17.462	39.878	13.843	14.605	10.668	1.2	1.2	25.4	26.0	11 000	14 000	LM11749R	LM11710	0.058	0.028
19.050	45.237	15.494	16.637	12.065	1.2	1.2	29.4	30.1	9 400	13 000	LM11949	LM11910	0.081	0.044
	49.225	19.845	21.539	14.288	1.2	1.2	37.7	37.7	8 900	12 000	09078	09195	0.124	0.065
	49.225	21.209	19.050	17.462	1.2	1.6	37.7	37.7	8 900	12 000	09067	09196	0.114	0.084
21.430	50.005	17.526	18.288	13.970	1.2	1.2	39.1	40.7	8 500	11 000	M12649	M12610	0.119	0.058
21.987	45.974	15.494	16.637	12.065	1.2	1.2	30.1	34.6	8 900	12 000	LM12749	LM12711	0.078	0.043
22.225	50.005	17.526	18.288	13.970	1.2	1.2	39.1	40.7	8 500	11 000	M12648	M12610	0.115	0.058
	56.896	19.368	19.837	15.875	1.2	1.2	40.0	43.1	7 600	10 000	1755	1729	0.150	0.100
	57.150	22.225	22.225	17.462	0.8	1.6	52.6	55.7	7 600	10 000	1280	1220	0.189	0.105
22.606	47.000	15.500	15.500	12.000	1.6	1.0	28.0	32.8	8 700	12 000	LM72849	LM72810	0.076	0.047
23.812	50.292	14.224	14.732	10.668	1.6	1.2	31.2	37.0	7 800	10 000	L44640R	L44610	0.099	0.039
	56.896	19.368	19.837	15.875	0.8	1.2	40.0	43.1	7 600	10 000	1779	1729	0.141	0.100
25.400	50.005	13.495	14.260	9.525	1.0	1.0	26.7	28.8	7 900	11 000	07100	07196	0.084	0.035
	50.005	13.495	14.260	9.525	1.6	1.0	26.7	28.8	7 900	11 000	07100S	07196	0.082	0.035
	50.292	14.224	14.732	10.668	1.2	1.2	31.2	37.0	7 800	10 000	L44643R	L44610	0.092	0.039
	61.912	19.050	20.638	14.288	0.8	2.0	44.6	50.7	6 400	8 600	15101	15243	0.215	0.080
	62.000	19.050	20.638	14.288	3.6	1.2	44.6	50.7	6 400	8 600	15100	15245	0.215	0.081
	63.500	19.050	20.638	14.288	0.8	1.2	44.6	50.7	6 400	8 600	15101	15250R	0.215	0.097
26.988	64.292	21.432	21.432	16.670	1.6	1.6	55.2	70.7	6 400	8 500	M86643R	M86610	0.248	0.127
	65.088	22.225	21.463	15.875	1.6	1.6	47.8	51.7	5 600	7 900	23100	23256	0.231	0.140
	72.233	25.400	25.400	19.842	0.8	2.4	66.9	87.4	5 700	7 600	HM88630	HM88610	0.391	0.185
	50.292	14.224	14.732	10.668	3.6	1.2	31.2	37.0	7 800	10 000	L44649R	L44610	0.083	0.039
26.988	60.325	19.842	17.462	15.875	3.6	1.6	37.8	42.7	7 000	9 400	15580	15523	0.140	0.122
	62.000	19.050	20.638	14.288	0.8	1.2	44.6	50.7	6 400	8 600	15106	15245	0.206	0.081
28.575	57.150	19.845	19.355	15.875	3.6	1.6	48.8	57.1	7 000	9 300	1988R	1922	0.151	0.076
	62.000	19.050	20.638	14.288	3.6	1.2	44.6	50.7	6 400	8 600	15112	15245	0.193	0.081

Remark) Inch series tapered roller bearings with bore diameter larger than 200 mm are shown in catalogue "large size ball & roller bearings," CAT. NO. 211E.

d (28.575) – 38.000 mm

Boundary dimensions (mm)							Basic load ratings (kN)		Limiting speeds (min ⁻¹)		Bearing No. ¹⁾		(Refer.) Mass (kg)	
<i>d</i>	<i>D</i>	<i>T</i>	<i>B</i>	<i>C</i>	<i>r</i> ²⁾ min.	<i>r</i> ₁ min.	<i>C</i> _r	<i>C</i> _{0r}	Grease lub.	Oil lub.	Cone	Cup	Cone	Cup
28.575	64.292	21.432	21.432	16.670	1.6	1.6	55.2	70.7	6 400	8 500	M86647R	M86610	0.225	0.127
	66.421	23.812	25.433	19.050	1.2	1.2	67.0	75.2	6 500	8 700	2689	2631	0.249	0.165
	68.262	22.225	22.225	17.462	0.8	1.6	51.0	61.1	6 000	8 000	02474	02420	0.252	0.150
	73.025	22.225	22.225	17.462	0.8	3.2	55.0	65.7	5 500	7 400	02872	02820	0.319	0.158
29.000	50.292	14.224	14.732	10.668	3.6	1.2	28.9	37.2	7 600	10 000	L45449	L45410	0.079	0.036
29.367	66.421	23.812	25.433	19.050	3.6	1.2	67.0	75.2	6 500	8 700	2690	2631	0.242	0.165
30.162	64.292	21.432	21.432	16.670	1.6	1.6	55.2	70.7	6 400	8 500	M86649R	M86610	0.213	0.127
	68.262	22.225	22.225	17.462	2.4	1.6	56.1	71.1	6 000	7 900	M88043	M88010	0.258	0.144
30.213	62.000	19.050	20.638	14.288	3.6	1.2	44.6	50.7	6 400	8 600	15118	15245	0.181	0.081
	62.000	19.050	20.638	14.288	1.6	1.2	44.6	50.7	6 400	8 600	15119	15245	0.183	0.081
	62.000	19.050	20.638	14.288	0.8	1.2	44.6	50.7	6 400	8 600	15120	15245	0.183	0.081
30.226	69.012	19.845	19.583	15.875	0.8	3.2	46.1	55.0	5 900	7 800	14116	14274	0.226	0.131
31.750	59.131	15.875	16.764	11.811	sp	1.2	35.8	43.1	6 600	8 800	LM67048	LM67010	0.120	0.062
	62.000	18.161	19.050	14.288	sp	1.2	44.6	50.7	6 400	8 600	15123	15245	0.157	0.081
	62.000	19.050	20.638	14.288	3.6	1.2	44.6	50.7	6 400	8 600	15125	15245	0.169	0.081
	62.000	19.050	20.638	14.288	0.8	1.2	44.6	50.7	6 400	8 600	15126	15245	0.171	0.081
	66.421	25.400	25.357	20.638	0.8	3.2	71.4	85.1	6 000	8 000	2580	2520	0.281	0.123
	68.262	22.225	22.225	17.462	1.6	1.6	56.1	71.1	6 000	7 900	M88046	M88010	0.245	0.144
	68.262	22.225	22.225	17.462	3.6	1.6	51.0	61.1	6 000	8 000	02475	02420	0.224	0.150
	73.025	22.225	22.225	17.462	3.6	3.2	55.0	65.7	5 600	7 400	02875	02820	0.293	0.158
73.025	29.370	27.783	23.020	1.2	3.2	74.3	101	5 600	7 500	HM88542	HM88510	0.377	0.238	
73.812	29.370	27.783	23.020	1.2	3.2	74.3	101	5 600	7 500	HM88542	HM88512	0.377	0.254	
33.338	68.262	22.225	22.225	17.462	0.8	1.6	56.1	71.1	6 000	7 900	M88048	M88010	0.231	0.144
	73.025	29.370	27.783	23.020	0.8	3.2	74.3	101	5 600	7 500	HM88547	HM88510	0.360	0.238
	76.200	29.370	28.575	23.020	0.8	3.2	79.5	107	5 400	7 200	HM89443	HM89410	0.415	0.254
34.925	65.088	18.034	18.288	13.970	sp	1.2	48.0	58.5	6 000	8 000	LM48548	LM48510	0.164	0.086
	69.012	26.982	26.721	15.875	0.8	1.2	46.1	55.0	5 900	7 800	14136A	14276	0.254	0.133
	72.233	25.400	25.400	19.842	2.4	2.4	66.9	87.4	5 700	7 600	HM88649	HM88610	0.301	0.185
	73.025	23.812	24.608	19.050	1.6	0.8	72.2	87.3	5 600	7 400	25877R	25821	0.310	0.165
	76.200	29.370	28.575	23.812	1.6	3.2	80.9	97.4	5 400	7 200	31594	31520	0.388	0.232
34.980	59.131	15.875	16.764	11.938	sp	1.2	35.7	48.5	6 400	8 500	L68149	L68110	0.112	0.056
	59.975	15.875	16.764	11.938	sp	1.2	35.7	48.5	6 400	8 500	L68149	L68111	0.112	0.063
35.000	79.375	23.812	25.400	19.050	0.8	0.8	81.1	105	5 000	6 700	26883R	26822	0.414	0.186
35.717	72.233	25.400	25.400	19.842	3.6	2.4	66.9	87.4	5 700	7 600	HM88648	HM88610	0.291	0.185
36.487	73.025	23.812	24.608	19.050	1.6	0.8	72.2	87.3	5 600	7 400	25880R	25821	0.294	0.165
36.512	76.200	29.370	28.575	23.020	3.6	0.8	79.5	107	5 400	7 200	HM89449	HM89411	0.386	0.258
	79.375	23.812	25.400	19.050	0.8	0.8	81.1	105	5 000	6 700	26877R	26822	0.404	0.186
38.000	63.000	17.000	17.000	13.500	sp	sp	43.5	58.2	6 000	8 000	JL69349	JL69310	0.128	0.070

Notes 1) Bearings identified by prefix J feature special designed accuracy.

2) 'sp' means special chamfer shape.

Remark) Inch series tapered roller bearings with bore diameter larger than 200 mm are shown in catalogue "large size ball & roller bearings," CAT. NO. 211E.

Tapered roller bearings inch series

d 38.100 – 41.275 mm

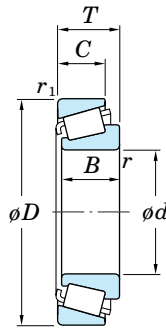

Boundary dimensions (mm)							Basic load ratings (kN)		Limiting speeds (min ⁻¹)		Bearing No.		(Refer.) Mass (kg)	
d	D	T	B	C	$r^{1)}$ min.	r_1 min.	C_r	C_{0r}	Grease lub.	Oil lub.	Cone	Cup	Cone	Cup
38.100	65.088	18.034	18.288	13.970	sp	1.2	42.9	56.5	5 800	7 800	LM29748	LM29710	0.154	0.079
	65.088	19.812	18.288	15.748	2.4	1.2	42.9	56.5	5 800	7 800	LM29749	LM29711	0.159	0.092
	71.438	15.875	16.520	11.908	1.6	1.0	46.1	53.8	5 700	7 600	19150R	19281	0.167	0.105
	71.996	17.018	16.520	14.288	1.6	1.6	46.1	53.8	5 700	7 600	19150R	19283	0.167	0.133
	71.996	19.000	20.638	14.237	3.6	1.6	49.7	61.3	5 600	7 400	16150	16282	0.207	0.121
	72.238	20.638	20.638	15.875	3.6	1.2	49.7	61.3	5 600	7 400	16150	16284	0.207	0.144
	72.238	23.812	20.638	19.050	3.6	2.4	49.7	61.3	5 600	7 400	16150	16283	0.207	0.183
	76.200	23.812	25.654	19.050	3.6	0.8	74.1	92.2	5 400	7 200	2788R	2729	0.308	0.189
	79.375	29.370	29.771	23.812	3.6	3.2	87.4	105	5 200	6 900	3490	3420	0.419	0.256
	82.550	29.370	28.575	23.020	0.8	3.2	87.3	117	4 900	6 600	HM801346	HM801310	0.483	0.282
	82.550	29.370	28.575	23.020	2.4	3.2	87.3	117	4 900	6 600	HM801346X	HM801310	0.483	0.282
	88.501	26.988	29.083	22.225	3.6	1.6	98.2	112	4 900	6 500	418	414	0.523	0.325
39.688	73.025	23.812	25.654	19.050	3.6	0.8	74.1	92.2	5 400	7 200	2789R	2735X	0.288	0.134
40.000	76.200	20.638	20.940	15.507	1.6	1.2	57.3	65.9	5 300	7 000	28158	28300	0.266	0.137
	80.000	21.000	22.403	17.826	3.6	1.2	68.0	74.8	4 900	6 600	344	332	0.334	0.144
	80.000	21.000	22.403	17.826	0.8	1.2	68.0	74.8	4 900	6 600	344A	332	0.334	0.144
40.483	82.550	29.370	28.575	23.020	3.6	3.2	87.3	117	4 900	6 600	HM801349	HM801310	0.450	0.282
41.275	73.025	16.667	17.462	12.700	3.6	1.6	45.9	55.8	5 200	6 900	18590	18520	0.199	0.085
	73.431	19.558	19.812	14.732	3.6	0.8	57.8	73.0	5 200	7 000	LM501349	LM501310	0.227	0.107
	73.431	21.430	19.812	16.604	3.6	0.8	57.8	73.0	5 200	7 000	LM501349	LM501314	0.227	0.126
	73.431	23.012	19.812	18.186	3.6	2.4	57.8	73.0	5 200	7 000	LM501349	LM501311	0.227	0.140
	76.200	18.009	17.384	14.288	1.6	1.6	51.6	63.3	5 200	6 900	11162R	11300	0.221	0.127
	76.200	22.225	23.020	17.462	3.6	0.8	66.3	83.3	5 200	6 900	24780R	24720	0.275	0.148
	80.000	21.000	22.403	17.826	3.6	1.2	68.0	74.8	4 900	6 600	342	332	0.317	0.144
	85.725	30.162	30.162	23.812	3.6	1.2	108	136	4 800	6 400	3877	3821	0.506	0.324
	88.900	20.638	22.225	16.513	3.6	1.2	74.3	87.3	4 400	5 800	365A	362A	0.458	0.164
	88.900	30.162	29.370	23.020	0.8	3.2	99.6	125	4 600	6 100	HM803145	HM803110	0.577	0.318
	88.900	30.162	29.370	23.020	3.6	3.2	99.6	125	4 600	6 100	HM803146	HM803110	0.574	0.318
	90.488	39.688	40.386	33.338	3.6	3.2	132	169	4 500	6 000	4388	4335	0.775	0.454
95.250	30.162	29.370	23.020	3.6	3.2	104	140	3 300	4 400	HM804840	HM804810	0.719	0.351	
104.775	36.512	36.512	28.575	1.6	3.2	141	195	3 800	5 100	HM807035	HM807010	1.19	0.497	

Note 1) 'sp' means special chamfer shape.

Remark) Inch series tapered roller bearings with bore diameter larger than 200 mm are shown in catalogue "large size ball & roller bearings," CAT. NO. 211E.

d 42.875 – 50.000 mm

Boundary dimensions (mm)							Basic load ratings (kN)		Limiting speeds (min ⁻¹)		Bearing No. ¹⁾		(Refer.) Mass (kg)	
<i>d</i>	<i>D</i>	<i>T</i>	<i>B</i>	<i>C</i>	<i>r</i> _{min.}	<i>r</i> _{1 min.}	<i>C</i> _r	<i>C</i> _{0r}	Grease lub.	Oil lub.	Cone	Cup	Cone	Cup
42.875	82.931	23.812	25.400	19.050	3.6	0.8	77.2	100	4 800	6 300	25577	25520	0.382	0.200
44.450	82.931	23.812	25.400	19.050	5.2	0.8	77.2	100	4 800	6 300	25582	25520	0.361	0.200
	84.138	30.162	30.886	23.812	3.6	3.2	95.8	120	4 600	6 200	3578R	3520	0.479	0.221
	85.000	20.638	21.692	17.462	2.4	1.2	71.8	81.7	4 600	6 200	355	354A	0.344	0.160
	85.000	20.638	21.692	17.462	0.8	1.2	71.8	81.7	4 600	6 200	355A	354A	0.344	0.160
	88.900	30.162	29.370	23.020	3.6	3.2	99.6	125	4 600	6 100	HM803149	HM803110	0.525	0.318
	95.250	27.783	28.575	22.225	0.8	2.4	108	141	4 100	5 400	33885	33821	0.714	0.264
	95.250	30.162	29.370	23.020	0.8	2.4	104	140	3 300	4 400	HM804842	HM804810	0.673	0.351
	95.250	30.162	29.370	23.020	3.6	2.4	104	140	3 300	4 400	HM804843	HM804810	0.670	0.351
	95.250	30.958	28.301	20.638	3.6	0.8	88.7	98.4	3 700	5 200	53177	53375	0.558	0.363
	95.250	30.958	28.575	22.225	3.6	0.8	99.7	120	3 700	5 100	HM903249	HM903210	0.614	0.383
	104.775	36.512	36.512	28.575	3.6	3.2	141	195	3 800	5 100	HM807040	HM807010	1.13	0.497
	111.125	30.162	26.909	20.638	3.6	3.2	111	150	3 100	4 300	55175CR	55437	0.939	0.507
	111.125	30.162	26.909	20.638	0.8	3.2	111	150	3 100	4 300	55176CR	55437	0.939	0.507
44.983	93.264	30.162	30.302	23.812	3.6	3.2	103	137	4 200	5 500	3776	3720	0.650	0.288
44.988	95.250	30.958	28.575	22.225	3.6	0.8	99.7	120	3 700	5 100	HM903248	HM903210	0.606	0.383
45.242	73.431	19.558	19.812	15.748	3.6	0.8	55.6	78.1	5 100	6 700	LM102949	LM102910	0.209	0.100
	77.788	19.842	19.842	15.080	3.6	0.8	57.1	73.5	4 900	6 500	LM603049	LM603011	0.243	0.120
	77.788	21.430	19.842	16.667	3.6	0.8	57.1	73.5	4 900	6 500	LM603049	LM603012	0.243	0.138
	79.974	19.842	19.842	15.080	3.6	0.8	57.1	73.5	4 900	6 500	LM603049	LM603014	0.243	0.152
45.618	85.000	23.812	25.400	19.050	3.6	2.4	77.2	100	4 800	6 300	25590	25526	0.344	0.241
45.987	74.976	18.000	18.000	14.000	2.4	1.6	52.6	74.6	5 000	6 600	LM503349R	LM503310	0.207	0.095
46.038	79.375	17.462	17.462	13.495	2.8	1.6	47.1	59.1	4 800	6 400	18690	18620	0.208	0.123
	85.000	20.638	21.692	17.462	3.6	1.2	71.8	81.7	4 600	6 200	359A	354A	0.323	0.160
	85.000	20.638	21.692	17.462	2.4	1.2	71.8	81.7	4 600	6 200	359S	354A	0.323	0.160
47.625	88.900	20.638	22.225	16.513	3.6	1.2	74.3	87.3	4 400	5 800	369A	362A	0.373	0.164
	88.900	25.400	25.400	19.050	3.6	3.2	87.1	112	4 400	5 900	M804049	M804010	0.450	0.216
	95.250	30.162	29.370	23.020	3.6	3.2	104	140	3 300	4 400	HM804846	HM804810	0.617	0.351
	96.838	21.000	21.946	15.875	0.8	0.8	80.4	101	3 900	5 200	386A	382A	0.563	0.177
	101.600	34.925	36.068	26.988	3.6	3.2	131	159	4 000	5 300	528	522	0.871	0.411
	104.775	30.162	29.317	24.605	4.8	3.2	109	144	3 700	4 900	463	453X	0.838	0.372
111.125	30.162	26.909	20.638	3.6	3.2	97.7	119	3 200	4 400	55187	55437	0.817	0.507	
48.412	95.250	30.162	29.370	23.020	2.4	3.2	104	140	3 300	4 400	HM804848	HM804810	0.606	0.351
49.212	88.900	20.638	22.225	16.513	0.8	1.2	74.3	87.3	4 400	5 800	365S	362A	0.366	0.164
	104.775	36.512	36.512	28.575	3.6	3.2	141	195	3 800	5 100	HM807044	HM807010	1.03	0.497
	114.300	44.450	44.450	34.925	3.6	3.2	189	230	3 800	5 000	65390	65320	1.28	0.894
50.000	82.000	21.501	21.501	17.000	3.0	0.5	71.7	97.9	4 500	6 000	JLM104948	JLM104910	0.304	0.128
	88.900	20.638	22.225	16.513	2.0	1.2	74.3	87.3	4 400	5 800	365	362A	0.346	0.164
	90.000	28.000	28.000	23.000	3.0	2.5	105	138	4 300	5 800	JM205149	JM205110	0.508	0.243
	105.000	37.000	36.000	29.000	3.0	2.8	149	205	3 800	5 100	JHM807045	JHM807012	1.01	0.523
110.000	22.000	21.996	18.824	0.8	1.2	86.4	116	3 400	4 500	396	394A	0.777	0.263	

Note 1) Bearings identified by prefix J feature special designed accuracy.

Remark) Inch series tapered roller bearings with bore diameter larger than 200 mm are shown in catalogue "large size ball & roller bearings," CAT. NO. 211E.

Tapered roller bearings inch series

d 50.800 – 54.991 mm

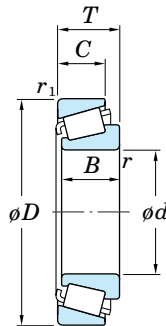

Boundary dimensions (mm)							Basic load ratings (kN)		Limiting speeds (min ⁻¹)		Bearing No.		(Refer.) Mass (kg)	
d	D	T	B	C	r min.	r_1 min.	C_r	C_{0r}	Grease lub.	Oil lub.	Cone	Cup	Cone	Cup
50.800	82.550	21.590	22.225	16.510	3.6	1.2	61.2	84.3	4 500	6 000	LM104949	LM104911	0.287	0.131
	88.900	17.462	17.462	13.495	3.6	1.2	49.7	65.5	4 400	5 900	18790	18724	0.226	0.190
	88.900	20.638	22.225	16.513	1.6	1.2	74.3	87.3	4 400	5 800	368	362A	0.333	0.164
	88.900	20.638	22.225	16.513	3.6	1.2	74.3	87.3	4 400	5 800	368A	362A	0.331	0.164
	92.075	24.608	25.400	19.845	3.6	0.8	84.8	119	4 200	5 600	28580R	28521	0.453	0.247
	93.264	30.162	30.302	23.812	3.6	3.2	103	137	4 200	5 500	3780	3720	0.547	0.288
	95.250	27.783	28.575	22.225	3.6	0.8	108	141	4 100	5 400	33889	33822	0.604	0.267
	96.838	21.000	21.946	15.875	0.8	0.8	80.4	101	3 900	5 200	385AX	382A	0.521	0.177
	97.630	24.608	24.608	19.446	3.6	0.8	89.6	131	3 900	5 200	28678	28622	0.569	0.267
	101.600	31.750	31.750	25.400	3.6	3.2	114	143	3 900	5 200	49585	49520	0.736	0.384
	101.600	34.925	36.068	26.988	0.8	3.2	131	159	4 000	5 300	529	522	0.806	0.411
	104.775	30.162	30.958	23.812	6.4	3.2	126	165	3 700	4 900	45284	45220	0.873	0.345
	104.775	36.512	36.512	28.575	3.6	3.2	141	195	3 800	5 100	HM807046	HM807010	0.995	0.497
	107.950	36.512	36.957	28.575	3.6	3.2	138	172	3 800	5 100	537	532X	0.969	0.569
	111.125	30.162	26.909	20.638	3.6	3.2	111	150	3 100	4 300	55200CR	55437	0.840	0.507
112.712	30.162	30.162	23.812	3.6	3.2	147	207	3 300	4 500	39575	39520	1.13	0.359	
123.825	36.512	32.791	25.400	3.6	3.2	156	190	2 900	4 000	72200C	72487	1.32	0.782	
51.592	88.900	20.638	22.225	16.513	2.0	1.2	74.3	87.3	4 400	5 800	368S	362A	0.321	0.164
	92.075	24.608	25.400	19.845	3.6	0.8	84.8	119	4 200	5 600	28584R	28521	0.435	0.247
52.388	104.775	30.162	29.317	24.605	1.6	3.2	109	144	3 700	4 900	468	453X	0.748	0.372
	88.900	19.050	19.050	13.492	2.4	2.0	62.9	86.8	4 200	5 600	LM806649	LM806610	0.312	0.135
53.975	95.250	27.783	28.575	22.225	1.6	0.8	108	141	4 100	5 400	33895	33822	0.550	0.267
	104.775	36.512	36.512	28.575	3.6	3.2	141	195	3 800	5 100	HM807049	HM807010	0.921	0.497
54.991	120.650	41.275	41.275	31.750	3.6	3.2	174	217	3 500	4 600	621	612	1.36	0.853
	123.825	36.512	32.791	25.400	3.6	3.2	156	190	2 900	4 000	72212C	72487	1.26	0.782
	123.825	38.100	36.678	30.162	3.6	3.2	162	223	3 200	4 200	557S	552A	1.47	0.756
54.991	135.755	53.975	56.007	44.450	3.6	3.2	266	357	3 000	4 000	6381	6320	2.75	1.37

Remark) Inch series tapered roller bearings with bore diameter larger than 200 mm are shown in catalogue "large size ball & roller bearings," CAT. NO. 211E.

d 55.000 – 66.675 mm

Boundary dimensions (mm)							Basic load ratings (kN)		Limiting speeds (min ⁻¹)		Bearing No. ¹⁾		(Refer.) Mass (kg)	
d	D	T	B	C	r _{min.}	r _{1 min.}	C _r	C _{0r}	Grease lub.	Oil lub.	Cone	Cup	Cone	Cup
55.000	90.000	23.000	23.000	18.500	1.6	0.5	81.4	115	4 200	5 500	JLM506849	JLM506810	0.370	0.183
	95.000	29.000	29.000	23.500	1.6	2.8	110	150	4 000	5 300	JM207049	JM207010	0.567	0.256
	96.838	21.000	21.946	15.875	2.4	0.8	80.4	101	3 900	5 200	385	382A	0.461	0.177
	110.000	39.000	39.000	32.000	3.0	2.5	176	224	3 600	4 900	JH307749	JH307710	1.16	0.560
55.562	97.630	24.608	24.608	19.446	3.6	0.8	89.6	131	3 900	5 200	28680	28622	0.492	0.267
55.575	96.838	21.000	21.946	15.875	2.4	0.8	80.4	101	3 900	5 200	389	382A	0.452	0.177
57.150	96.838	21.000	21.946	15.875	2.4	0.8	80.4	101	3 900	5 200	387	382A	0.428	0.177
	96.838	21.000	21.946	15.875	3.6	0.8	80.4	101	3 900	5 200	387A	382A	0.426	0.177
	96.838	21.000	21.946	15.875	5.2	0.8	80.4	101	3 900	5 200	387AS	382A	0.422	0.177
	96.838	21.000	21.946	15.875	0.8	0.8	80.4	101	3 900	5 200	387S	382A	0.431	0.177
	98.425	21.000	21.946	17.826	2.4	0.8	80.4	101	3 900	5 200	387	382	0.428	0.233
	104.775	30.162	29.317	24.605	2.4	3.2	109	144	3 700	4 900	462	453X	0.685	0.372
	104.775	30.162	29.317	24.605	3.6	3.2	109	144	3 700	4 900	469	453X	0.682	0.372
	104.775	30.162	30.958	23.812	6.4	0.8	126	165	3 700	4 900	45291	45221	0.742	0.350
	112.712	30.162	30.162	23.812	3.6	3.2	147	207	3 300	4 500	39580	39520	1.05	0.355
	112.712	30.162	30.162	23.812	7.9	3.2	147	207	3 300	4 500	39581	39520	1.03	0.355
	123.825	36.512	32.791	25.400	3.6	3.2	156	190	2 900	4 000	72225C	72487	1.19	0.782
	140.030	36.512	33.236	23.520	3.6	2.4	150	177	2 500	3 500	78225	78551	1.70	0.915
57.531	96.838	21.000	21.946	15.875	3.6	0.8	80.4	101	3 900	5 200	388A	382A	0.420	0.177
60.325	100.000	25.400	25.400	19.845	3.6	3.2	91.4	137	3 700	4 900	28985	28921	0.533	0.230
	101.600	25.400	25.400	19.845	3.6	3.2	91.4	137	3 700	4 900	28985	28920	0.533	0.269
	127.000	44.450	44.450	34.925	3.6	3.2	208	269	3 300	4 400	65237	65500	1.59	1.02
	136.525	46.038	46.038	36.512	3.6	3.2	231	369	2 800	3 700	H715332	H715311	2.56	0.950
61.912	110.000	22.000	21.996	18.824	0.8	1.2	86.4	116	3 400	4 500	392	394A	0.606	0.259
	146.050	41.275	39.688	25.400	3.6	3.2	199	232	2 300	3 300	H913842R	H913810	2.20	0.898
63.500	107.950	25.400	25.400	19.050	1.6	3.2	92.8	143	3 400	4 500	29586	29520	0.649	0.277
	110.000	22.000	21.996	18.824	3.6	1.2	86.4	116	3 400	4 500	395	394A	0.575	0.259
	110.000	25.400	25.400	19.050	3.6	1.2	92.8	143	3 400	4 500	29585	29521	0.644	0.333
	112.712	30.162	30.162	23.812	3.6	3.2	147	207	3 300	4 500	39585	39520	0.908	0.355
65.000	105.000	24.000	23.000	18.500	3.0	1.0	95.3	129	3 500	4 700	JLM710949	JLM710910	0.513	0.234
	110.000	28.000	28.000	22.500	3.0	2.8	136	191	3 400	4 600	JM511946	JM511910	0.733	0.338
	120.000	39.000	38.500	32.000	3.0	2.8	189	255	3 200	4 300	JH211749	JH211710	1.27	0.618
65.088	135.755	53.975	56.007	44.450	3.6	3.2	266	357	3 000	4 000	6379	6320	2.34	1.37
66.675	110.000	22.000	21.996	18.824	0.8	1.2	86.4	116	3 400	4 500	395A	394A	0.524	0.259
	110.000	22.000	21.996	18.824	3.6	1.2	86.4	116	3 400	4 500	395S	394A	0.519	0.259
	112.712	30.162	30.048	23.812	3.6	0.8	111	164	3 400	4 500	3984	3925	0.700	0.454
	112.712	30.162	30.162	23.812	3.6	3.2	147	207	3 300	4 500	39590	39520	0.832	0.355
	112.712	30.162	30.162	23.812	3.6	0.8	147	207	3 300	4 500	39590	39521	0.832	0.360
	117.475	30.162	30.162	23.812	3.6	3.2	118	179	3 200	4 200	33262	33462	0.910	0.436
	122.238	38.100	38.354	29.718	3.6	1.6	191	249	3 200	4 300	HM212049	HM212010	1.26	0.596
	135.755	53.975	56.007	44.450	4.3	3.2	266	357	3 000	4 000	6386	6320	2.27	1.37
	177.800	57.150	53.975	37.308	3.6	3.2	334	372	2 100	2 900	HH914449	HH914412	4.26	2.51

Note 1) Bearings identified by prefix J feature special designed accuracy.

Remark) Inch series tapered roller bearings with bore diameter larger than 200 mm are shown in catalogue "large size ball & roller bearings," CAT. NO. 211E.

Tapered roller bearings

inch series

d 68.262 – (76.200) mm

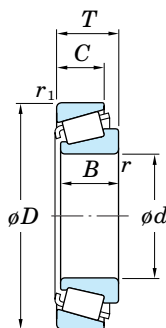

Boundary dimensions (mm)							Basic load ratings (kN)		Limiting speeds (min ⁻¹)		Bearing No. ¹⁾		(Refer.) Mass (kg)	
d	D	T	B	C	r min.	r_1 min.	C_r	C_{or}	Grease lub.	Oil lub.	Cone	Cup	Cone	Cup
68.262	110.000	22.000	21.996	18.824	2.4	1.2	86.4	116	3 400	4 500	399A	394A	0.493	0.259
	110.000	22.000	21.996	18.824	5.2	1.2	86.4	116	3 400	4 500	399AS	394A	0.485	0.259
	136.525	41.275	41.275	31.750	3.6	3.2	241	308	2 900	3 800	H414245	H414210	1.92	0.788
	136.525	46.038	46.038	36.512	3.6	3.2	231	369	2 800	3 700	H715343	H715311	2.27	0.950
69.850	112.712	25.400	25.400	19.050	1.6	3.2	97.0	155	3 200	4 300	29675	29620	0.676	0.270
	117.475	30.162	30.162	23.812	3.6	3.2	118	179	3 200	4 200	33275	33462	0.830	0.436
	120.000	29.794	29.007	24.237	3.6	2.0	118	161	3 200	4 200	482	472	0.791	0.487
	120.000	32.545	32.545	26.195	3.6	3.2	150	218	3 100	4 200	47487R	47420	1.01	0.476
	123.825	30.162	29.007	24.605	3.6	3.2	118	161	3 200	4 200	482	472X	0.791	0.625
	127.000	36.512	36.170	28.575	3.6	3.2	156	226	3 000	4 000	566	563	1.24	0.648
146.050	41.275	39.688	25.400	3.6	3.2	202	237	2 300	3 300	H913849R	H913810	1.95	0.898	
70.000	110.000	26.000	25.000	20.500	1.0	2.5	103	158	3 300	4 400	JLM813049	JLM813010	0.590	0.300
	115.000	29.000	29.000	23.000	3.0	2.5	123	173	3 200	4 300	JM612949	JM612910	0.776	0.358
71.438	117.475	30.162	30.162	23.812	3.6	3.2	118	179	3 200	4 200	33281	33462	0.789	0.436
	120.000	32.545	32.545	26.195	3.6	3.2	150	218	3 100	4 200	47490R	47420	0.964	0.476
	127.000	36.512	36.170	28.575	3.6	3.2	156	226	3 000	4 000	567A	563	1.19	0.648
	136.525	41.275	41.275	31.750	3.6	3.2	241	308	2 900	3 800	H414249	H414210	1.80	0.788
136.525	46.038	46.038	36.512	3.6	3.2	231	369	2 800	3 700	H715345	H715311	2.15	0.950	
73.025	112.712	25.400	25.400	19.050	3.6	3.2	97.0	155	3 200	4 300	29685	29620	0.602	0.270
	117.475	30.162	30.162	23.812	3.6	3.2	118	179	3 200	4 200	33287	33462	0.747	0.436
	127.000	36.512	36.170	28.575	3.6	3.2	156	226	3 000	4 000	567	563	1.14	0.648
	149.225	53.975	54.229	44.450	3.6	3.2	285	404	2 700	3 500	6460	6420	2.79	1.61
75.000	115.000	25.000	25.000	19.000	3.0	2.8	101	151	3 100	4 200	JLM714149	JLM714110	0.612	0.269
	120.000	31.000	29.500	25.000	3.0	2.8	145	216	3 100	4 100	JM714249	JM714210	0.846	0.430
76.200	121.442	24.608	23.012	17.462	3.6	2.0	90.0	127	3 000	4 000	34301	34478	0.617	0.313
	127.000	30.162	31.000	22.225	6.4	3.2	143	225	2 400	3 200	42688	42620	1.04	0.434
	133.350	30.162	29.769	22.225	6.4	3.2	133	198	2 700	3 600	495AX	492A	1.20	0.430
	133.350	33.338	33.338	26.195	6.4	3.2	154	245	2 700	3 700	47678R	47620	1.29	0.577
	135.733	44.450	46.101	34.925	3.6	3.2	213	337	2 800	3 700	5760	5735	1.85	0.877
	136.525	30.162	29.769	22.225	3.6	3.2	133	198	2 700	3 600	495A	493	1.26	0.544
	139.992	36.512	36.098	28.575	3.6	3.2	175	262	2 700	3 600	575R	572	1.64	0.779

Note 1) Bearings identified by prefix J feature special designed accuracy.

Remark) Inch series tapered roller bearings with bore diameter larger than 200 mm are shown in catalogue "large size ball & roller bearings," CAT. NO. 211E.

d (76.200) – (101.600) mm

Boundary dimensions (mm)							Basic load ratings (kN)		Limiting speeds (min ⁻¹)		Bearing No. ¹⁾		(Refer.) Mass (kg)			
<i>d</i>	<i>D</i>	<i>T</i>	<i>B</i>	<i>C</i>	<i>r</i> _{min.}	<i>r</i> _{1 min.}	<i>C</i> _r	<i>C</i> _{0r}	Grease lub.	Oil lub.	Cone	Cup	Cone	Cup		
76.200	150.089	44.450	46.672	36.512	3.6	3.2	264	368	2 500	3 400	748SR	742	2.51	1.06		
	161.925	49.212	46.038	31.750	3.6	3.2	246	286	2 100	2 900			9285R	9220	3.00	1.38
77.788	117.475	25.400	25.400	19.050	3.6	3.2	101	166	3 100	4 100	LM814849	LM814810	0.619	0.295		
	121.442	24.608	23.012	17.462	3.6	2.0	90.0	127	3 000	4 000			34306	34478	0.583	0.313
	127.000	30.162	31.000	22.225	3.6	3.2	143	225	2 400	3 200			42690	42620	1.00	0.434
79.375	190.500	57.150	57.531	46.038	3.6	3.2	440	602	2 000	2 700	HH221431	HH221410	6.16	2.21		
80.000	130.000	35.000	34.000	28.500	3.2	2.5	168	256	2 800	3 800	JM515649	JM515610	1.19	0.575		
80.962	133.350	30.162	29.769	22.225	3.6	3.2	133	198	2 700	3 600	496	492A	1.12	0.429		
82.550	125.412	25.400	25.400	19.845	3.6	1.6	101	162	2 900	3 800	27687	27620	0.710	0.344		
	133.350	30.162	29.769	22.225	3.6	3.2	133	198	2 700	3 600			495	492A	1.08	0.429
	133.350	33.338	33.338	26.195	3.6	0.8	154	245	2 700	3 700			47686R	47620A	1.13	0.577
82.550	133.350	39.688	39.688	32.545	6.7	3.2	177	306	2 800	3 700	HM516448	HM516410	1.33	0.763		
	139.700	36.512	36.098	28.575	3.6	3.2	175	262	2 700	3 600			580R	572X	1.41	0.765
	139.992	36.512	36.098	28.575	3.6	3.2	175	262	2 700	3 600			580R	572	1.41	0.779
	139.992	36.512	36.098	28.575	6.7	3.2	175	262	2 700	3 600			582R	572	1.40	0.779
	146.050	41.275	41.275	31.750	3.6	3.2	208	301	2 600	3 400			663	653	1.91	0.880
83.345	125.412	25.400	25.400	19.845	3.6	1.6	101	162	2 900	3 800	27690	27620	0.689	0.344		
85.000	130.000	30.000	29.000	24.000	3.0	2.5	142	228	2 800	3 700	JM716649	JM716610	0.937	0.456		
	140.000	39.000	38.000	31.500	3.0	2.5	203	308	2 700	3 500			JHM516849	JHM516810	1.54	0.759
85.026	150.089	44.450	46.672	36.512	3.6	3.2	264	368	2 500	3 400	749R	742	2.12	1.06		
85.725	133.350	30.162	29.769	22.225	3.6	3.2	133	198	2 700	3 600	497	492A	0.978	0.429		
	142.138	42.862	42.862	34.133	4.8	3.2	219	351	2 600	3 500			HM617049	HM617010	1.72	0.902
	146.050	41.275	41.275	31.750	3.6	3.2	208	301	2 600	3 400			665	653	1.77	0.880
85.725	146.050	41.275	41.275	31.750	6.4	3.2	208	301	2 600	3 400	665A	653	1.76	0.880		
	152.400	39.688	36.322	30.162	3.6	3.2	183	287	2 400	3 300			596	592A	1.83	1.04
	161.925	47.625	48.260	38.100	3.6	3.2	273	391	2 400	3 200			758	752	2.67	1.59
	161.925	47.625	48.260	38.100	3.6	3.2	273	391	2 400	3 200			758	752	2.67	1.59
88.900	152.400	39.688	39.688	30.162	6.4	3.2	248	359	2 400	3 200	HM518445	HM518410	2.10	0.768		
	161.925	47.625	48.260	38.100	3.6	3.2	273	391	2 400	3 200			759	752	2.50	1.59
	161.925	53.975	55.100	42.862	3.6	3.2	316	471	2 400	3 200			6580R	6535	3.09	1.65
89.974	146.975	40.000	40.000	32.500	7.1	3.6	206	310	2 500	3 300	HM218248	HM218210	1.66	0.784		
95.000	150.000	35.000	34.000	27.000	3.0	2.5	187	294	2 400	3 300	JM719149	JM719113	1.43	0.766		
95.250	128.588	15.875	15.083	11.908	1.6	1.6	58.0	93.0	2 600	3 500	LL319349	LL319310	0.393	0.147		
	147.638	35.717	36.322	26.192	5.2	0.8	183	287	2 400	3 300			594A	592XE	1.45	0.62
100.000	155.000	36.000	35.000	28.000	3.0	2.5	204	328	2 300	3 100	JM720249	JM720210	1.64	0.763		
	160.000	41.000	40.000	32.000	3.0	2.5	237	378	2 300	3 000			JHM720249	JHM720210	2.11	0.964
100.012	157.162	36.512	36.116	26.195	3.6	3.2	180	288	2 300	3 000	52393	52618	1.74	0.694		
101.600	157.162	36.512	36.116	26.195	3.6	3.2	180	288	2 300	3 000	52400	52618	1.67	0.694		
	157.162	36.512	36.116	26.195	7.9	3.2	180	288	2 300	3 000			52401	52618	1.64	0.694
	168.275	41.275	41.275	30.162	3.6	3.2	224	349	2 200	3 000			687	672	2.15	1.22

Note 1) Bearings identified by prefix J feature special designed accuracy.

Remark) Inch series tapered roller bearings with bore diameter larger than 200 mm are shown in catalogue "large size ball & roller bearings," CAT. NO. 211E.

Tapered roller bearings inch series

d (101.600) – 200.000 mm

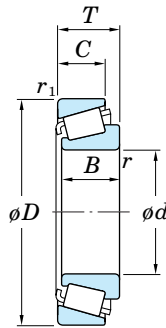

Boundary dimensions (mm)							Basic load ratings (kN)		Limiting speeds (min ⁻¹)		Bearing No. ¹⁾		(Refer.) Mass (kg)	
d	D	T	B	C	r min.	r_1 min.	C_r	C_{0r}	Grease lub.	Oil lub.	Cone	Cup	Cone	Cup
101.600	180.975	47.625	48.006	38.100	3.6	3.2	288	438	2 100	2 800	780	772	3.09	1.92
	190.500	57.150	57.531	44.450	7.9	3.2	385	565	2 100	2 700	861R	854	4.20	2.66
	190.500	57.150	57.531	46.038	7.9	3.2	440	602	2 000	2 700	HH221449	HH221410	4.72	2.21
104.775	180.975	47.625	48.006	38.100	3.6	3.2	288	438	2 100	2 800	782	772	2.90	1.92
106.362	165.100	36.512	36.512	26.988	3.6	3.2	195	325	2 200	2 900	56418R	56650	1.84	0.852
107.950	146.050	21.432	21.432	16.670	1.6	1.6	86.4	167	2 300	3 100	L521949R	L521910	0.665	0.325
	158.750	23.020	21.438	15.875	3.6	3.2	104	169	2 200	3 000	37425	37625	0.893	0.484
	165.100	36.512	36.512	26.988	3.6	3.2	195	325	2 200	2 900	56425R	56650	1.76	0.852
109.538	158.750	23.020	21.438	15.875	6.4	6.4	104	169	2 200	3 000	37431	37625	0.848	0.484
109.987	159.987	34.925	34.925	26.988	3.6	3.2	184	319	2 200	2 900	LM522549	LM522510	1.55	0.784
110.000	165.000	35.000	35.000	26.500	3.0	2.5	195	325	2 200	2 900	JM822049	JM822010	1.64	0.826
114.300	177.800	41.275	41.275	30.162	3.6	3.2	234	380	2 000	2 700	64450R	64700	2.45	1.10
	190.500	47.625	49.212	34.925	3.6	3.2	303	483	1 900	2 600	71450	71750	3.33	1.72
	212.725	66.675	66.675	53.975	7.1	3.2	513	699	1 800	2 400	HH224346	HH224310	6.64	3.03
	212.725	66.675	66.675	53.975	7.1	3.2	450	674	1 800	2 400	938	932	5.96	4.07
	228.600	53.975	49.428	38.100	3.6	3.2	430	651	1 300	1 900	HM926740	HM926710	7.26	2.78
114.976	212.725	66.675	66.675	53.975	7.1	3.2	513	699	1 800	2 400	HH224349	HH224310	6.58	3.03
115.087	190.500	47.625	49.212	34.925	3.6	3.2	303	483	1 900	2 600	71453	71750	3.28	1.72
117.475	180.975	34.925	31.750	25.400	3.6	3.2	171	247	2 000	2 700	68462	68712	1.75	1.04
170.000	230.000	39.000	38.000	31.000	3.0	2.5	291	558	1 400	1 900	JHM534149	JHM534110	3.17	1.29
180.000	250.000	47.000	45.000	37.000	3.0	2.5	365	705	1 300	1 700	JM736149	JM736110	4.47	2.10
190.000	260.000	46.000	44.000	36.500	3.0	2.5	369	723	1 200	1 700	JM738249	JM738210	4.71	2.18
196.850	254.000	28.575	27.783	21.433	1.6	1.6	188	387	1 200	1 600	L540049	L540010	2.34	1.02
200.000	300.000	65.000	62.000	51.000	3.6	2.5	617	1 140	1 100	1 500	JHM840449	JHM840410	9.97	5.13

Note 1) Bearings identified by prefix J feature special designed accuracy.

Remark) Inch series tapered roller bearings with bore diameter larger than 200 mm are shown in catalogue "large size ball & roller bearings," CAT. NO. 211E.



KOYO



Spherical roller bearings

Spherical roller bearings feature a large load rating capacity and self-aligning capability.

This type of bearing is suitable for low-or medium-speed applications which involve heavy or impact loading.

- These bearings are divided into R, RR, RH, RHR and RHA types, which differ in internal structure. (refer to Table 1.)
- Each type can be produced with a cylindrical bore or tapered bore.

Bearing with a tapered bore can be fit and removed easily using an adapter assembly or withdrawal sleeve. The rate of taper is equivalent among all bearing series.

240 and 241 series ...1 : 30 (supplementary code "K30")

Others ...1 : 12 (supplementary code "K")

Spherical roller bearings

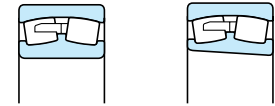

Cylindrical bore Tapered bore

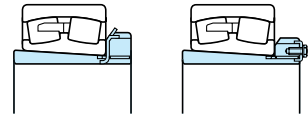

Bore diameter 25 – 300 mm

Adapter assemblies

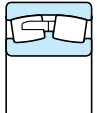
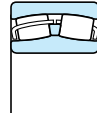

Bore diameter 20 – 280 mm

Table 1 Spherical roller bearings : types and structures

Structure	 R, RR type*	 RH, RHR type	 RHA type
Roller	Convex asymmetrical roller	Convex symmetrical roller	Convex symmetrical roller
Cage	Copper alloy prong type machined cage *(excl. 240 and 241 series)	Pressed steel cage	Copper alloy integral type machined cage
Inner ring (with or without rib)	With center rib	Without center rib (guide ring)	Without center rib (guide ring)
	With ribs on both sides (to prevent rollers from falling) *(excl. 240 and 241 series)	Without ribs on both sides	With ribs on both sides (to prevent rollers from falling)
Characteristics	Superior to RH and RHA types in high-speed performance.	The load rating capacity is larger than that of R type. (There are some exceptional cases due to different interior specifications.)	

* Some 240 or 241 series R type bearings have a pressed cage. Some of them are provided with an inner ring which does not have ribs.

■ Spherical roller bearings for shaker screens

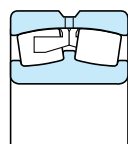

- These bearings consist of convex asymmetric rollers and a prong type, copper alloy, outer ring guided, machined cage. This cage possesses optimum characteristics for use with shaker screens.
- The bearings most commonly used with shaker screens are 223 series spherical roller bearings. They are identified by the supplementary code "ROVSW502." The outer ring outside diameter tolerance of these bearings is held to a small allowable variation.

Spherical roller bearings

■ Bearings with lubrication holes and a lubrication groove

- Outer rings can be provided with lubrication holes, a lubrication groove and an anti-rotation pin hole. (Specifications are given in Table 4.)
- Inner rings can also be provided with lubrication holes and a lubrication groove.

Table 2 Supplementary codes for identification of bearings with lubrication holes, lubrication groove and anti-rotation pin hole (outer ring)

Supplementary code		Number of lubrication holes	Hole layout
With lubrication holes and lubrication groove	With lubrication holes, lubrication groove and anti-rotation pin hole		
W33	W3N	3	3 equally spaced positions ¹⁾
W33A	W3NA	4	4 equally spaced positions
–	W3NB	5	6 equally spaced positions ²⁾
W33C	W3NC	6	6 equally spaced positions
–	W3ND	7	8 equally spaced positions ²⁾
W33T	–	8	8 equally spaced positions

Notes 1) 4 or 6 holes are provided in smaller size bearings. Consult Koyo.
2) One hole is used for the anti-rotation pin.

Table 3 Supplementary codes for identification of bearings with lubrication holes and / or lubrication groove

Supplementary code	Inner ring		Outer ring	
	Number of lubrication holes	Lubrication groove	Number of lubrication holes	Lubrication groove
W513	3	–	3	○
W518	3	–	3	–
W26	3	–	–	–

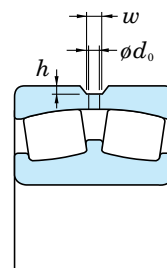

Table 4 Lubrication hole and lubrication groove dimensions

Unit mm

Bore diameter number	Nominal bore diameter <i>d</i>	239			230			240			231			241			222			232			213			223		
		<i>d</i> ₀	<i>w</i>	<i>h</i>	<i>d</i> ₀	<i>w</i>	<i>h</i>	<i>d</i> ₀	<i>w</i>	<i>h</i>	<i>d</i> ₀	<i>w</i>	<i>h</i>	<i>d</i> ₀	<i>w</i>	<i>h</i>	<i>d</i> ₀	<i>w</i>	<i>h</i>	<i>d</i> ₀	<i>w</i>	<i>h</i>	<i>d</i> ₀	<i>w</i>	<i>h</i>	<i>d</i> ₀	<i>w</i>	<i>h</i>
20	100	–	–	–	3.5	5	1	–	–	–	4	6	1.2	–	–	–	5	7	1.5	6	8	1.5	4	6	1.5	6	8	1.5
22	110	–	–	–	5	7	1.2	–	–	–	4	6	1.2	4	6	1.2	5	7	1.5	6	8	1.5	4	6	1.5	8	10	2
24	120	–	–	–	5	7	1.2	4	6	1.2	4	6	1.2	4	6	1.2	5	7	1.5	8	10	2	4	6	1.5	10	12	2.5
26	130	–	–	–	5	7	1.2	4	6	1.2	4	6	1.5	4	6	1.5	6	8	1.5	8	10	2	–	–	–	12	14	3
28	140				5	7	1.2	5	7	1.2	6	8	1.5	6	8	1.5	8	10	2	8	10	2	–	–	–	12	14	3
30	150	5	7	1.2	6	8	1.5	6	8	1.5	8	10	2	8	10	2	10	12	2.5	8	10	2	–	–	–	12	14	3
32	160	5	7	1.2	6	8	1.5	6	8	1.5	10	12	2.5	10	12	2	10	12	2.5	10	12	2.5	–	–	–	12	14	3
34	170	5	7	1.2	8	10	2	8	10	2	10	12	2.5	10	12	2	12	14	3	10	12	2.5	–	–	–	12	14	3
36	180	5	7	1.2	10	12	2.5	10	12	2.5	10	12	2.5	10	12	2	12	14	3	10	12	2.5	–	–	–	14	16.5	4
38	190	5	7	1.2	10	12	2.5	–	–	–	10	12	2.5	10	12	2	12	14	3	12	14	3	–	–	–	14	16.5	4
40	200	6	8	1.5	10	12	2.5	10	12	2.5	12	14	3	12	14	3	12	14	3	12	14	3	–	–	–	14	16.5	4
44	220	6	8	1.5	10	12	2.5	10	12	2.5	12	14	3	12	14	3	12	14	3	12	14	3	–	–	–	14	16.5	4
48	240	6	8	1.5	10	12	2.5	10	12	2.5	12	14	3	12	14	3	14	16.5	4	14	16.5	4	–	–	–	14	16.5	4
52	260	10	12	2.5	12	14	3	12	14	3	12	14	3	12	14	3	14	16.5	4	14	16.5	4	–	–	–	14	16.5	4
56	280	10	12	2.5	12	14	3	12	14	3	12	14	3	12	14	3	14	16.5	4	14	16.5	4	–	–	–	14	16.5	4
60	300	10	12	2.5	12	14	3	12	14	3	12	14	3	12	14	3	14	16.5	4	14	16.5	4	–	–	–	14	16.5	4
64	320	10	12	2.5	12	14	3	12	14	3	14	16.5	4	14	16.5	4	14	16.5	4	14	16.5	4	–	–	–	14	16.5	4
68	340	12	14	3	14	16.5	4	14	16.5	3	14	16.5	4	14	16.5	4	14	16.5	4	14	16.5	4	–	–	–	14	16.5	4
72	360	12	14	3	14	16.5	4	14	16.5	3	14	16.5	4	14	16.5	4	14	16.5	4	14	16.5	4	–	–	–	14	16.5	4
76	380	12	14	3	14	16.5	4	14	16.5	3	14	16.5	4	14	16.5	4	14	16.5	4	14	16.5	4	–	–	–	14	16.5	4
80	400	12	14	3	14	16.5	4	14	16.5	4	14	16.5	4	14	16.5	4	14	16.5	4	14	16.5	4	–	–	–	14	16.5	4
84	420	12	14	3	14	16.5	4	14	16.5	4	14	16.5	4	14	16.5	4	14	16.5	4	14	16.5	4	–	–	–	14	16.5	4
88	440	14	16.5	4	14	16.5	4	14	16.5	4	14	16.5	4	14	16.5	4	14	16.5	4	14	16.5	4	–	–	–	14	16.5	4
92	460	14	16.5	4	14	16.5	4	14	16.5	4	14	16.5	4	14	16.5	4	–	–	–	14	16.5	4	–	–	–	14	16.5	4
96	480	14	16.5	4	14	16.5	4	14	16.5	4	14	16.5	4	14	16.5	4	–	–	–	14	16.5	4	–	–	–	14	16.5	4
/500	500	14	16.5	4	14	16.5	4	14	16.5	4	14	16.5	4	14	16.5	5	–	–	–	14	16.5	4	–	–	–	–	–	–

Boundary dimensions	As specified in JIS B 1512.
Tolerances	As specified in JIS B 1514, class 0.
Radial internal clearance	As specified in JIS B 1520. (refer to Table 2-8 on pp. A 18, 19.)
Standard cages	Refer to Table 5.
Allowable aligning angle	Refer to Table 5. (varies depending on bearing series.)
Equivalent radial load	Dynamic equivalent radial load $\left[\text{when } \frac{F_a}{F_r} \leq e \right] P_r = F_r + Y_1 F_a$ $\left[\text{when } \frac{F_a}{F_r} > e \right] P_r = 0.67F_r + Y_2 F_a$ Static equivalent radial load $P_{0r} = F_r + Y_0 F_a$

Remark) If the ratio of axial load to radial load exceeds the value e given in the specification table ($F_a / F_r > e$), slippage occurs between rollers in rows that are not axial-loaded and the raceway. This may cause smearing, especially when the bearing is large. Consult Koyo on the use of bearings under such conditions.

Table 5 Application of standard cages and allowable aligning angle

Bearing series	Standard cages		Allowable aligning angle
	Pressed cage	Machined cage	
239 R	—	23930R – 239/500R	0.026 rad (1.5°)
230 R	—	23038R – 230/500R	0.026 rad (1.5°)
RH	23022RH – 23036RH	—	
RHA	—	23038RHA – 23096RHA	
240 R	—	24038R – 240/500R	0.035 rad (2°)
RH	24024RH – 24036RH	—	
RHA	—	24038RHA – 24096RHA	
231 R	—	23136R – 231/500R	0.026 rad (1.5°)
RH	23122RH – 23134RH	—	
RHA	—	23136RHA – 23196RHA	
241 R	—	24136R – 241/500R	0.044 rad (2.5°)
RH	24122RH – 24134RH	—	
RHA	—	24136RHA – 24196RHA	
222 R(RR)	—	22232RR – 22272R	0.026 rad (1.5°)
RH(RHR)	22205RHR – 22230RH	—	
RHA	—	22232RHA – 22260RHA	
232 R	—	23232R – 232/500R	0.044 rad (2.5°)
RH	23218RH – 23230RH	—	
RHA	—	23232RHA – 23296RHA	
213 R	—	21328R – 21322R	0.017 rad (1°)
RH	21311RH – 21322RH	—	
223 R(RR)	—	22328R – 22360R	0.035 rad (2°)
RH(RHR)	22308RHR – 22326RH	—	
RHA	—	22328RHA – 22356RHA	

Spherical roller bearings

d 25 – 80 mm

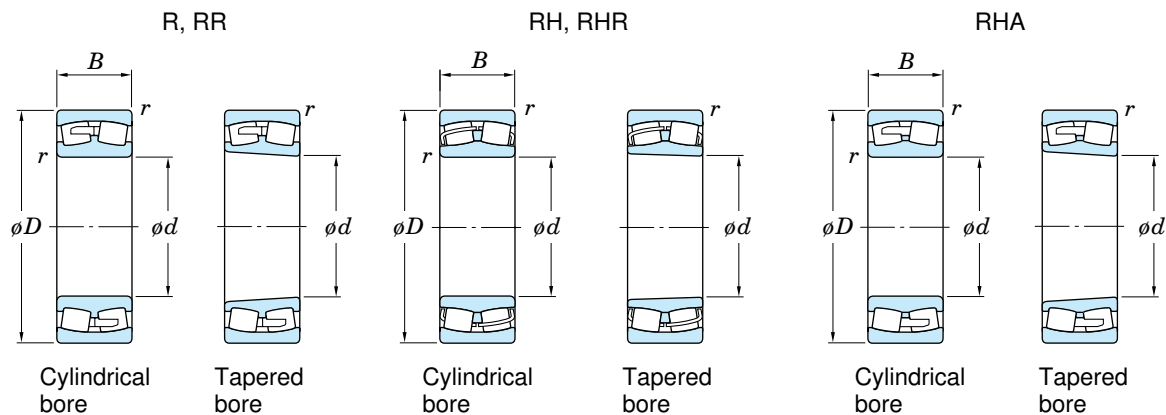

Boundary dimensions (mm)				Basic load ratings (kN)		Limiting speeds (min ⁻¹)		Bearing No.		(Refer.) Mass (kg)	
d	D	B	$r_{\min.}$	C_r	C_{0r}	Grease lub.	Oil lub.	Cylindrical bore	Tapered bore	Cylindrical bore	Tapered bore
25	52	18	1	45.4	48.1	7 000	9 300	22205RHR	22205RHRK	0.220	0.215
30	62	20	1	61.2	65.9	5 900	7 900	22206RHR	22206RHRK	0.360	0.350
	72	19	1.1	59.3	62.7	5 200	7 000	21306RH	21306RHK	0.380	0.370
35	72	23	1.1	80.3	88.7	5 000	6 700	22207RHR	22207RHRK	0.550	0.540
	80	21	1.5	69.6	75.3	4 500	6 000	21307RH	21307RHK	0.510	0.500
40	80	23	1.1	90.9	102	4 500	6 000	22208RHR	22208RHRK	0.660	0.650
	90	23	1.5	85.7	95.5	4 100	5 500	21308RH	21308RHK	0.710	0.700
	90	33	1.5	136	152	4 100	5 500	22308RHR	22308RHRK	1.25	1.23
45	85	23	1.1	95.6	110	4 200	5 600	22209RHR	22209RHRK	0.720	0.710
	100	25	1.5	108	124	3 600	4 900	21309RH	21309RHK	0.950	0.940
	100	36	1.5	166	183	3 700	4 900	22309RHR	22309RHRK	1.62	1.59
50	90	23	1.1	103	122	3 900	5 200	22210RHR	22210RHRK	0.780	0.770
	110	27	2	128	151	3 300	4 400	21310RH	21310RHK	1.20	1.18
	110	40	2	204	237	3 300	4 500	22310RHR	22310RHRK	2.21	2.18
55	100	25	1.5	124	144	3 400	4 600	22211RHR	22211RHRK	1.05	1.04
	120	29	2	144	165	3 000	4 100	21311RH	21311RHK	1.60	1.58
	120	43	2	236	264	3 000	4 000	22311RHR	22311RHRK	2.72	2.67
60	110	28	1.5	153	181	3 100	4 200	22212RHR	22212RHRK	1.45	1.43
	130	31	2.1	168	193	2 800	3 700	21312RH	21312RHK	1.95	1.92
	130	46	2.1	283	334	2 800	3 700	22312RHR	22312RHRK	3.43	3.37
65	120	31	1.5	178	211	2 900	3 800	22213RHR	22213RHRK	1.84	1.81
	140	33	2.1	194	232	2 600	3 400	21313RH	21313RHK	2.45	2.41
	140	48	2.1	305	360	2 600	3 400	22313RHR	22313RHRK	4.15	4.07
70	125	31	1.5	187	222	2 700	3 600	22214RHR	22214RHRK	1.94	1.91
	150	35	2.1	215	260	2 400	3 200	21314RH	21314RHK	3.00	2.95
	150	51	2.1	348	413	2 400	3 200	22314RHR	22314RHRK	5.01	4.92
75	130	31	1.5	193	236	2 600	3 400	22215RHR	22215RHRK	2.05	2.01
	160	37	2.1	246	298	2 200	3 000	21315RH	21315RHK	3.55	3.50
	160	55	2.1	393	473	2 200	3 000	22315RHR	22315RHRK	6.13	6.02
80	140	33	2	217	271	2 400	3 200	22216RHR	22216RHRK	2.61	2.57
	170	39	2.1	275	339	2 100	2 800	21316RH	21316RHK	4.20	4.14
	170	58	2.1	431	521	2 100	2 800	22316RHR	22316RHRK	7.18	7.04

Remark) Standard cage types used for the above bearings are shown in Table 5 earlier in this section.

d 85 – (150) mm

Boundary dimensions (mm)				Basic load ratings (kN)		Limiting speeds (min ⁻¹)		Bearing No.		(Refer.) Mass (kg)	
<i>d</i>	<i>D</i>	<i>B</i>	<i>r</i> _{min.}	<i>C</i> _r	<i>C</i> _{0r}	Grease lub.	Oil lub.	Cylindrical bore	Tapered bore	Cylindrical bore	Tapered bore
85	150	36	2	258	324	2 200	3 000	22217RHR	22217RHRK	3.23	3.16
	180	41	3	300	372	2 000	2 600	21317RH	21317RHK	5.00	4.93
	180	60	3	481	586	2 000	2 600	22317RHR	22317RHRK	8.41	8.26
90	160	40	2	298	381	2 100	2 800	22218RHR	22218RHRK	4.01	3.94
	160	52.4	2	336	482	2 100	2 800	23218RH	23218RHK	4.60	4.47
	190	43	3	330	416	1 900	2 500	21318RH	21318RHK	5.80	5.71
	190	64	3	538	662	1 900	2 500	22318RHR	22318RHRK	9.87	9.68
95	170	43	2.1	334	422	2 000	2 600	22219RHR	22219RHRK	4.90	4.80
	200	45	3	362	461	1 800	2 300	21319RH	21319RHK	7.15	7.05
	200	67	3	586	726	1 800	2 300	22319RHR	22319RHRK	11.6	11.38
100	150	37	1.5	208	332	2 100	2 800	23020RH	—	2.80	—
	180	46	2.1	377	481	1 900	2 500	22220RHR	22220RHRK	5.82	5.72
	180	60.3	2.1	425	629	1 900	2 500	23220RH	23220RHK	6.70	6.51
	215	47	3	416	524	1 600	2 200	21320RH	21320RHK	8.80	8.68
	215	73	3	700	877	1 600	2 200	22320RHR	22320RHRK	14.7	14.4
110	170	45	2	300	486	1 900	2 500	23022RH	23022RHK	4.50	4.38
	180	56	2	385	605	1 800	2 400	23122RH	23122RHK	5.55	5.37
	180	69	2	469	778	1 800	2 400	24122RH	24122RHK30	6.53	6.44
	200	53	2.1	491	642	1 700	2 200	22222RHR	22222RHRK	8.37	8.22
	200	69.8	2.1	537	792	1 700	2 200	23222RH	23222RHK	9.70	9.40
	240	50	3	484	616	1 400	1 900	21322RH	21322RHK	12.0	11.8
	240	80	3	828	1 040	1 400	1 900	22322RHR	22322RHRK	20.2	19.8
120	180	46	2	314	524	1 700	2 300	23024RH	23024RHK	4.90	4.77
	180	60	2	397	709	1 700	2 300	24024RH	24024RHK30	5.04	4.96
	200	62	2	454	714	1 600	2 200	23124RH	23124RHK	7.80	7.56
	200	80	2	605	1 020	1 600	2 200	24124RH	24124RHK30	9.64	9.54
	215	58	2.1	565	764	1 500	2 000	22224RHR	22224RHRK	10.6	10.4
	215	76	2.1	616	956	1 500	2 100	23224RH	23224RHK	12.0	11.6
	260	86	3	896	1 130	1 300	1 800	22324RHR	22324RHRK	24.1	23.6
130	200	52	2	404	674	1 600	2 100	23026RH	23026RHK	7.30	7.12
	200	69	2	512	914	1 600	2 100	24026RH	24026RHK30	7.43	7.33
	210	64	2	494	799	1 500	2 000	23126RH	23126RHK	8.55	8.27
	210	80	2	620	1 080	1 500	2 000	24126RH	24126RHK30	10.3	10.1
	230	64	3	658	914	1 400	1 900	22226RHR	22226RHRK	13.3	13.0
	230	80	3	702	1 090	1 400	1 900	23226RH	23226RHK	14.0	13.5
	280	93	4	1 040	1 340	1 200	1 600	22326RHR	22326RHRK	30.3	29.7
140	210	53	2	422	723	1 500	2 000	23028RH	23028RHK	7.80	7.60
	210	69	2	524	957	1 500	2 000	24028RH	24028RHK30	7.88	7.74
	225	68	2.1	565	940	1 400	1 900	23128RH	23128RHK	10.5	10.2
	225	85	2.1	702	1 220	1 400	1 900	24128RH	24128RHK30	12.3	12.1
	250	68	3	759	1 030	1 300	1 700	22228RHR	22228RHRK	16.4	16.1
	250	88	3	811	1 290	1 300	1 700	23228RH	23228RHK	18.5	17.9
	300	102	4	1 100	1 410	1 300	1 700	22328R	22328RK	36.2	35.5
	300	102	4	1 170	1 570	1 100	1 500	22328RH	22328RHK	35.7	34.9
150	210	45	2	334	622	1 600	2 100	23930R	23930RK	4.97	4.81

Remark) Standard cage types used for the above bearings are shown in Table 5 earlier in this section.

Spherical roller bearings

d (150) – (180) mm

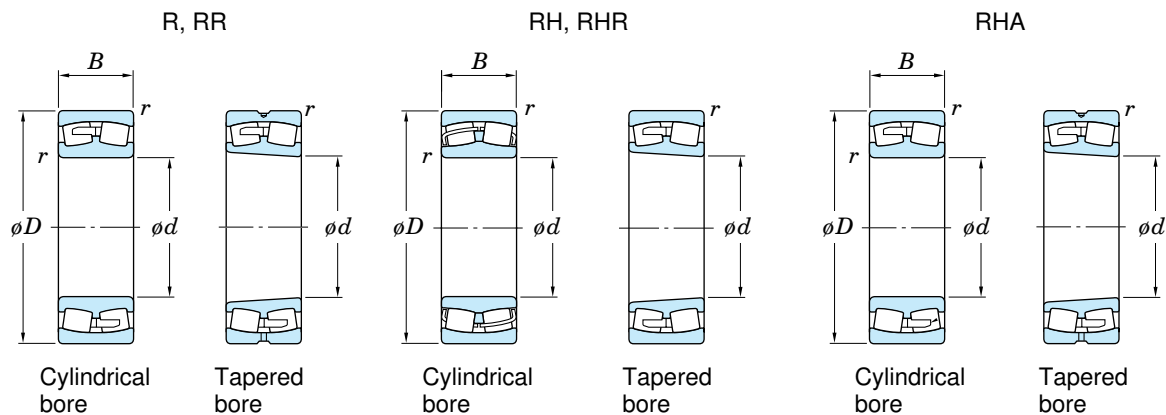

Boundary dimensions (mm)				Basic load ratings (kN)		Limiting speeds (min ⁻¹)		Bearing No.		(Refer.) Mass (kg)		
d	D	B	$r_{min.}$	C_r	C_{or}	Grease lub.	Oil lub.	Cylindrical bore	Tapered bore	Cylindrical bore	Tapered bore	
150	225	56	2.1	461	797	1 400	1 800	23030RH	23030RHK	9.50	9.26	
	225	75	2.1	593	1 100	1 400	1 800	24030RH	24030RHK30	9.81	9.64	
	250	80	2.1	717	1 230	1 300	1 700	23130RH	23130RHK	16.0	15.5	
	250	100	2.1	915	1 590	1 300	1 700	24130RH	24130RHK30	18.4	18.1	
	270	73	3	865	1 200	1 200	1 600	22230RHR	22230RHRK	20.6	20.2	
	270	96	3	959	1 540	1 200	1 600	23230RH	23230RHK	24.0	23.3	
	320	108	4	1 230	1 600	1 200	1 500	22330R	22330RK	43.6	42.7	
	320	108	4	1 290	1 740	1 200	1 500	22330RHA	22330RHAK	40.3	39.4	
	160	220	45	2	341	649	1 500	2 000	23932R	23932RK	5.25	5.08
		240	60	2.1	531	924	1 300	1 700	23032RH	23032RHK	11.3	11.0
240		80	2.1	679	1 270	1 300	1 700	24032RH	24032RHK30	12.0	11.8	
270		86	2.1	848	1 430	1 200	1 600	23132RH	23132RHK	20.5	19.9	
270		109	2.1	1 070	1 890	1 200	1 600	24132RH	24132RHK30	24.0	23.7	
290		80	3	885	1 270	1 200	1 600	22232R	22232RK	23.4	22.9	
290		80	3	897	1 320	1 200	1 600	22232RHA	22232RHAK	21.9	21.4	
290		104	3	1 030	1 650	1 200	1 600	23232R	23232RK	31.0	30.1	
290		104	3	1 100	1 780	1 200	1 600	23232RHA	23232RHAK	29.4	28.5	
340		114	4	1 380	1 790	1 100	1 400	22332R	22332RK	51.9	51.0	
340	114	4	1 420	1 940	1 100	1 400	22332RHA	22332RHAK	48.0	47.1		
170	230	45	2	353	691	1 400	1 900	23934R	23934RK	5.53	5.35	
	260	67	2.1	632	1 090	1 200	1 600	23034RH	23034RHK	15.9	15.5	
	260	90	2.1	828	1 540	1 200	1 600	24034RH	24034RHK30	16.3	16.0	
	280	88	2.1	916	1 550	1 100	1 500	23134RH	23134RHK	21.5	20.8	
	280	109	2.1	1 090	1 940	1 100	1 500	24134RH	24134RHK30	25.4	25.0	
	310	86	4	952	1 390	1 100	1 500	22234R	22234RK	29.0	28.4	
	310	86	4	1 010	1 490	1 100	1 500	22234RHA	22234RHAK	27.1	26.5	
	310	110	4	1 150	1 870	1 100	1 500	23234R	23234RK	37.5	36.5	
	310	110	4	1 210	1 940	1 100	1 500	23234RHA	23234RHAK	35.6	34.6	
	360	120	4	1 460	1 920	1 000	1 300	22334R	22334RK	62.0	60.8	
360	120	4	1 590	2 200	1 000	1 300	22334RHA	22334RHAK	57.3	56.1		
180	250	52	2	479	939	1 300	1 700	23936R	23936RK	8.00	7.80	
	280	74	2.1	768	1 330	1 100	1 400	23036RH	23036RHK	20.2	19.7	
	280	100	2.1	984	1 830	1 100	1 400	24036RH	24036RHK30	21.4	21.0	

Remark) Standard cage types used for the above bearings are shown in Table 5 earlier in this section.

d (180) – (220) mm

Boundary dimensions (mm)				Basic load ratings (kN)		Limiting speeds (min ⁻¹)		Bearing No.		(Refer.) Mass (kg)		
<i>d</i>	<i>D</i>	<i>B</i>	<i>r</i> _{min.}	<i>C_r</i>	<i>C_{0r}</i>	Grease lub.	Oil lub.	Cylindrical bore	Tapered bore	Cylindrical bore	Tapered bore	
180	300	96	3	1 000	1 800	1 100	1 500	23136R	23136RK	28.4	27.5	
	300	96	3	1 060	1 790	1 100	1 500	23136RHA	23136RHAK	26.5	25.6	
	300	118	3	1 160	2 010	1 000	1 400	24136R	24136RK30	33.3	32.7	
	300	118	3	1 250	2 240	1 100	1 500	24136RHA	24136RHAK30	31.8	31.2	
	320	86	4	978	1 450	1 100	1 400	22236R	22236RK	30.5	29.8	
	320	86	4	1 060	1 610	1 100	1 400	22236RHA	22236RHAK	28.5	27.8	
	320	112	4	1 190	1 980	1 100	1 400	23236R	23236RK	39.8	38.6	
	320	112	4	1 320	2 170	1 100	1 400	23236RHA	23236RHAK	37.7	36.5	
	380	126	4	1 740	2 360	920	1 200	22336R	22336RK	71.4	69.9	
	380	126	4	1 740	2 410	930	1 200	22336RHA	22336RHAK	66.0	64.5	
	190	260	52	2	486	969	1 200	1 600	23938R	23938RK	8.40	8.10
		290	75	2.1	736	1 370	1 100	1 500	23038R	23038RK	18.8	18.2
290		75	2.1	789	1 430	1 100	1 500	23038RHA	23038RHAK	17.2	16.6	
290		100	2.1	906	1 640	1 000	1 400	24038R	24038RK30	24.0	23.6	
290		100	2.1	1 010	1 920	1 100	1 500	24038RHA	24038RHAK30	22.4	22.0	
320		104	3	1 090	2 000	1 000	1 400	23138R	23138RK	35.5	34.4	
320		104	3	1 210	2 080	1 000	1 400	23138RHA	23138RHAK	33.2	32.1	
320		128	3	1 340	2 320	950	1 300	24138R	24138RK30	42.0	41.4	
320		128	3	1 460	2 630	1 000	1 400	24138RHA	24138RHAK30	40.1	39.5	
340		92	4	1 110	1 730	1 000	1 300	22238R	22238RK	37.4	36.6	
340		92	4	1 150	1 770	1 000	1 300	22238RHA	22238RHAK	34.9	34.1	
340		120	4	1 410	2 210	1 000	1 300	23238R	23238RK	47.4	46.0	
340		120	4	1 490	2 470	990	1 300	23238RHA	23238RHAK	44.9	43.5	
400		132	5	1 900	2 610	880	1 200	22338R	22338RK	84.1	82.4	
400		132	5	1 940	2 810	870	1 200	22338RHA	22338RHAK	77.7	76.0	
200	280	60	2.1	601	1 190	1 100	1 500	23940R	23940RK	12.0	11.6	
	310	82	2.1	890	1 670	1 000	1 400	23040R	23040RK	24.1	23.4	
	310	82	2.1	940	1 680	1 100	1 400	23040RHA	23040RHAK	22.0	21.3	
	310	109	2.1	1 030	1 900	950	1 300	24040R	24040RK30	30.5	30.0	
	310	109	2.1	1 180	2 230	1 100	1 400	24040RHA	24040RHAK30	28.5	28.0	
	340	112	3	1 240	2 250	980	1 300	23140R	23140RK	43.7	42.4	
	340	112	3	1 380	2 340	970	1 300	23140RHA	23140RHAK	40.8	39.5	
	340	140	3	1 450	2 490	890	1 200	24140R	24140RK30	51.9	51.1	
	340	140	3	1 660	2 970	990	1 300	24140RHA	24140RHAK30	49.5	48.7	
	360	98	4	1 230	1 930	930	1 200	22240R	22240RK	45.0	44.0	
	360	98	4	1 310	2 030	940	1 300	22240RHA	22240RHAK	42.0	41.0	
	360	128	4	1 550	2 610	940	1 300	23240R	23240RK	58.1	56.4	
	360	128	4	1 660	2 780	930	1 200	23240RHA	23240RHAK	55.1	53.4	
	420	138	5	2 010	2 750	830	1 100	22340R	22340RK	95.4	93.5	
	420	138	5	2 060	2 920	820	1 100	22340RHA	22340RHAK	88.1	86.2	
220	300	60	2.1	634	1 300	1 000	1 400	23944R	23944RK	13.0	12.6	
	340	90	3	984	1 890	940	1 300	23044R	23044RK	31.5	30.6	
	340	90	3	1 090	1 950	940	1 200	23044RHA	23044RHAK	28.8	27.9	
	340	118	3	1 240	2 300	850	1 100	24044R	24044RK30	39.6	39.0	
	340	118	3	1 380	2 630	950	1 300	24044RHA	24044RHAK30	37.0	36.4	
	370	120	4	1 440	2 700	880	1 200	23144R	23144RK	54.8	53.2	
	370	120	4	1 590	2 790	870	1 200	23144RHA	23144RHAK	51.2	49.6	
	370	150	4	1 680	2 900	800	1 100	24144R	24144RK30	65.0	64.0	

Remark) Standard cage types used for the above bearings are shown in Table 5 earlier in this section.

Spherical roller bearings

d (220) – (260) mm

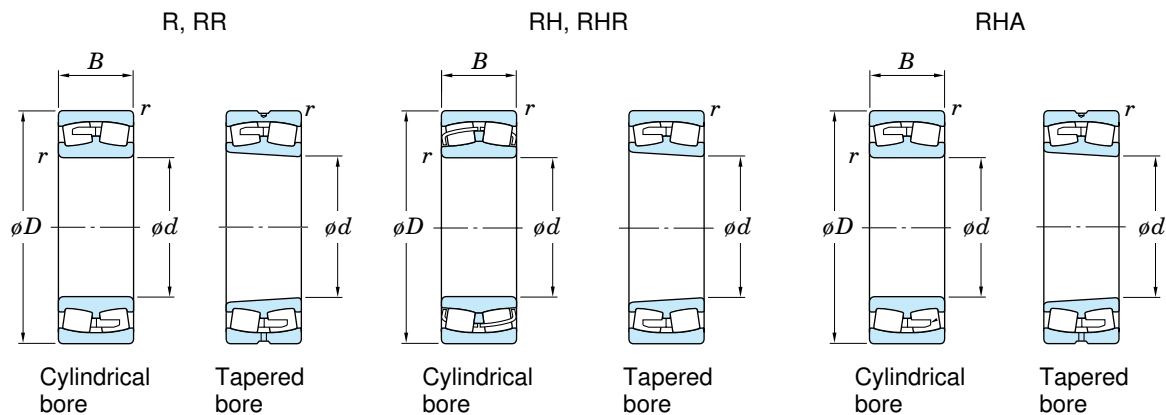

Boundary dimensions (mm)				Basic load ratings (kN)		Limiting speeds (min ⁻¹)		Bearing No.		(Refer.) Mass (kg)		
d	D	B	$r_{min.}$	C_r	C_{or}	Grease lub.	Oil lub.	Cylindrical bore	Tapered bore	Cylindrical bore	Tapered bore	
220	370	150	4	1 920	3 550	880	1 200	24144RHA	24144RHAK30	62.0	61.0	
	400	108	4	1 560	2 400	820	1 100	22244R	22244RK	63.0	61.7	
	400	108	4	1 590	2 440	820	1 100	22244RHA	22244RHAK	58.8	57.5	
	400	144	4	1 880	3 200	830	1 100	23244R	23244RK	81.6	79.2	
	400	144	4	2 020	3 350	810	1 100	23244RHA	23244RHAK	77.4	75.0	
	460	145	5	2 380	3 380	720	960	22344R	22344RK	124	122	
	460	145	5	2 370	3 470	730	970	22344RHA	22344RHAK	115	113	
	240	320	60	2.1	651	1 380	940	1 300	23948R	23948RK	14.0	13.5
		360	92	3	1 100	2 170	860	1 100	23048R	23048RK	34.9	33.8
		360	92	3	1 170	2 180	860	1 100	23048RHA	23048RHAK	31.9	30.9
360		118	3	1 310	2 530	780	1 000	24048R	24048RK30	42.4	41.8	
360		118	3	1 430	2 840	870	1 200	24048RHA	24048RHAK30	39.6	39.0	
400		128	4	1 630	3 080	790	1 100	23148R	23148RK	67.6	65.6	
400		128	4	1 810	3 200	790	1 000	23148RHA	23148RHAK	63.1	61.1	
400		160	4	1 970	3 500	720	960	24148R	24148RK30	80.3	79.0	
400		160	4	2 200	4 130	800	1 100	24148RHA	24148RHAK30	76.6	75.3	
440		120	4	1 920	2 940	730	970	22248R	22248RK	85.0	83.2	
440		120	4	1 920	2 990	730	970	22248RHA	22248RHAK	79.4	77.6	
440		160	4	2 340	3 990	730	970	23248R	23248RK	110	107	
440		160	4	2 460	4 130	730	970	23248RHA	23248RHAK	104	101	
500		155	5	2 610	4 020	650	870	22348R	22348RK	157	154	
500	155	5	2 720	3 990	650	870	22348RHA	22348RHAK	145	142		
260	360	75	2.1	914	1 880	820	1 100	23952R	23952RK	24.0	23.3	
	400	104	4	1 330	2 570	760	1 000	23052R	23052RK	50.7	49.3	
	400	104	4	1 470	2 720	760	1 000	23052RHA	23052RHAK	46.3	44.9	
	400	140	4	1 690	3 240	690	920	24052R	24052RK30	64.6	63.7	
	400	140	4	1 860	3 670	770	1 000	24052RHA	24052RHAK30	60.3	59.4	
	440	144	4	2 100	3 860	710	940	23152R	23152RK	93.6	90.8	
	440	144	4	2 220	4 000	700	930	23152RHA	23152RHAK	87.4	84.6	
	440	180	4	2 360	4 170	640	860	24152R	24152RK30	111	110	
	440	180	4	2 650	4 950	720	950	24152RHA	24152RHAK30	106	105	
	480	130	5	2 240	3 460	650	870	22252R	22252RK	110	108	
	480	130	5	2 230	3 430	650	870	22252RHA	22252RHAK	103	101	
	480	174	5	2 750	4 640	640	860	23252R	23252RK	144	140	

Remark) Standard cage types used for the above bearings are shown in Table 5 earlier in this section.

d (260) – 300 mm

Boundary dimensions (mm)				Basic load ratings (kN)		Limiting speeds (min ⁻¹)		Bearing No.		(Refer.) Mass (kg)		
<i>d</i>	<i>D</i>	<i>B</i>	<i>r</i> _{min.}	<i>C_r</i>	<i>C_{0r}</i>	Grease lub.	Oil lub.	Cylindrical bore	Tapered bore	Cylindrical bore	Tapered bore	
260	480	174	5	2 870	4 900	650	860	23252RHA	23252RHAK	137	133	
	540	165	6	2 830	4 380	590	780	22352R	22352RK	196	192	
	540	165	6	3 120	4 620	580	780	22352RHA	22352RHAK	181	177	
280	380	75	2.1	928	1 960	760	1 000	23956R	23956RK	26.0	25.2	
	420	106	4	1 430	2 860	710	950	23056R	23056RK	54.5	52.9	
	420	106	4	1 550	2 950	700	940	23056RHA	23056RHAK	49.8	48.2	
	420	140	4	1 740	3 420	640	850	24056R	24056RK30	68.5	67.4	
	420	140	4	1 960	4 000	710	950	24056RHA	24056RHAK30	64.0	62.9	
	460	146	5	2 140	4 280	660	880	23156R	23156RK	100	96.9	
	460	146	5	2 340	4 290	650	870	23156RHA	23156RHAK	93.4	90.3	
	460	180	5	2 440	4 440	600	790	24156R	24156RK30	118	116	
	460	180	5	2 740	5 240	660	880	24156RHA	24156RHAK30	113	112	
	500	130	5	2 100	3 380	610	810	22256R	22256RK	114	112	
	500	130	5	2 320	3 670	610	810	22256RHA	22256RHAK	106	104	
	500	176	5	2 690	4 910	610	820	23256R	23256RK	153	149	
	500	176	5	3 010	5 300	600	800	23256RHA	23256RHAK	145	141	
	580	175	6	3 150	4 910	530	710	22356R	22356RK	229	225	
	580	175	6	3 510	5 260	530	700	22356RHA	22356RHAK	212	208	
	300	420	90	3	1 280	2 610	680	910	23960R	23960RK	40.0	38.8
		460	118	4	1 750	3 480	630	840	23060R	23060RK	75.8	73.7
		460	118	4	1 940	3 700	630	840	23060RHA	23060RHAK	68.9	66.8
460		160	4	2 240	4 370	570	760	24060R	24060RK30	97.1	95.5	
460		160	4	2 420	4 910	640	850	24060RHA	24060RHAK30	90.7	89.1	
500		160	5	2 490	4 850	590	790	23160R	23160RK	132	128	
500		160	5	2 730	4 970	580	780	23160RHA	23160RHAK	123	119	
500		200	5	2 990	5 520	530	710	24160R	24160RK30	157	155	
500		200	5	3 320	6 420	590	790	24160RHA	24160RHAK30	150	148	
540		140	5	2 690	4 330	550	740	22260R	22260RK	145	142	
540		140	5	2 650	4 360	550	740	22260RHA	22260RHAK	135	132	
540		192	5	3 430	5 910	540	720	23260R	23260RK	197	192	
540		192	5	3 530	6 280	540	720	23260RHA	23260RHAK	187	182	
620		185	7.5	3 910	5 430	470	630	22360R	22360RK	289	284	

Remark) Standard cage types used for the above bearings are shown in Table 5 earlier in this section.

Adapter assemblies for spherical roller bearings

d_1 20 – (80) mm

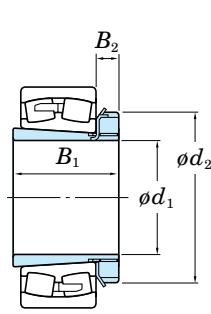

$d_1 \leq 180$ mm

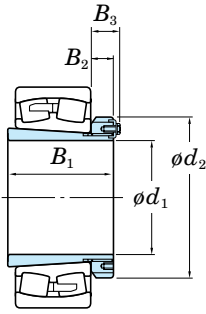

$d_1 \geq 200$ mm

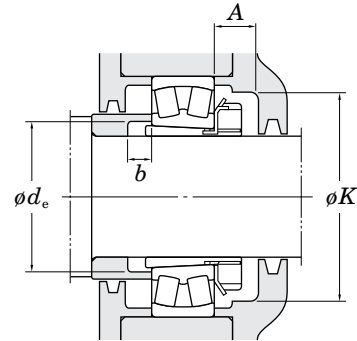

Boundary dimensions (mm)					Brg. bore (mm) <i>d</i>	Designations Bearing + adapter ass'y	Mounting dimensions (mm)				Mass Brg. + adapter ass'y (kg)	(Refer.)	
d_1	B_1	d_2	B_2	B_3			<i>A</i> min.	<i>K</i> min.	d_e min.	<i>b</i> min.		Adapter sleeve No.	Locknut No.
20	29	38	8	–	25	22205RHRK + H305X	15	45	29	5	0.290	A305X	AN05
25	31	45	8	–	30	22206RHRK + H306X	15	50	34	5	0.459	A306X	AN06
	31	45	8	–	30	21306RHK + H306X	15	50	34	6	0.479	A306X	AN06
30	35	52	9	–	35	22207RHRK + H307X	17	58	39	5	0.682	A307X	AN07
	35	52	9	–	35	21307RHK + H307X	17	58	39	7	0.642	A307X	AN07
35	36	58	10	–	40	22208RHRK + H308X	17	65	44	5	0.839	A308X	AN08
	36	58	10	–	40	21308RHK + H308X	17	65	44	5	0.888	A308X	AN08
	46	58	10	–	40	22308RHRK + H2308X	17	65	45	5	1.46	A2308X	AN08
40	39	65	11	–	45	22209RHRK + H309X	17	72	49	8	0.958	A309X	AN09
	39	65	11	–	45	21309RHK + H309X	17	72	49	5	1.19	A309X	AN09
	50	65	11	–	45	22309RHRK + H2309X	17	72	50	5	1.87	A2309X	AN09
45	42	70	12	–	50	22210RHRK + H310X	19	76	54	10	1.07	A310X	AN10
	42	70	12	–	50	21310RHK + H310X	19	76	54	5	1.48	A310X	AN10
	55	70	12	–	50	22310RHRK + H2310X	19	76	56	5	2.54	A2310X	AN10
50	45	75	12	–	55	22211RHRK + H311X	19	85	60	11	1.39	A311X	AN11
	45	75	12	–	55	21311RHK + H311X	19	85	60	6	1.93	A311X	AN11
	59	75	12	–	55	22311RHRK + H2311X	19	85	61	6	3.09	A2311X	AN11
55	47	80	13	–	60	22212RHRK + H312X	20	90	65	9	1.82	A312X	AN12
	47	80	13	–	60	21312RHK + H312X	20	90	65	5	2.31	A312X	AN12
	62	80	13	–	60	22312RHRK + H2312X	20	90	66	5	3.82	A2312X	AN12
60	50	85	14	–	65	22213RHRK + H313X	21	96	70	8	2.27	A313X	AN13
	50	85	14	–	65	21313RHK + H313X	21	96	70	5	2.87	A313X	AN13
	65	85	14	–	65	22313RHRK + H2313X	21	96	72	5	4.63	A2313X	AN13
65	55	98	15	–	75	22215RHRK + H315X	23	110	80	12	2.84	A315X	AN15
	55	98	15	–	75	21315RHK + H315X	23	110	80	5	4.33	A315X	AN15
	73	98	15	–	75	22315RHRK + H2315X	23	110	82	5	7.07	A2315X	AN15
70	59	105	17	–	80	22216RHRK + H316X	25	120	86	12	3.60	A316X	AN16
	59	105	17	–	80	21316RHK + H316X	25	120	86	5	5.17	A316X	AN16
	78	105	17	–	80	22316RHRK + H2316X	25	120	87	5	8.32	A2316X	AN16
75	63	110	18	–	85	22217RHRK + H317X	27	128	91	12	4.34	A317X	AN17
	63	110	18	–	85	21317RHK + H317X	27	128	91	6	6.11	A317X	AN17
	82	110	18	–	85	22317RHRK + H2317X	27	128	94	6	9.71	A2317X	AN17
80	65	120	18	–	90	22218RHRK + H318X	28	139	96	10	5.31	A318X	AN18

d_1 (80) – (150) mm

Boundary dimensions (mm)					Brg. bore (mm) d	Designations Bearing + adapter ass'y	Mounting dimensions (mm)				Mass Brg. + adapter ass'y (kg)	(Refer.)		
d_1	B_1	d_2	B_2	B_3			A min.	K min.	d_e min.	b min.		Adapter sleeve No.	Locknut No.	
80	86	120	18	–	90	23218RHK + H2318X	28	139	99	18	6.16	A2318X	AN18	
	65	120	18	–	90	21318RHK + H318X	28	139	96	6	7.08	A318X	AN18	
	86	120	18	–	90	22318RHRK + H2318X	28	139	99	6	11.37	A2318X	AN18	
85	68	125	19	–	95	22219RHRK + H319X	29	145	102	9	6.36	A319X	AN19	
	68	125	19	–	95	21319RHK + H319X	29	145	102	7	8.61	A319X	AN19	
	90	125	19	–	95	22319RHRK + H2319X	29	145	105	7	13.3	A2319X	AN19	
90	71	130	20	–	100	22220RHRK + H320X	30	150	107	8	7.41	A320X	AN20	
	97	130	20	–	100	23220RHK + H2320X	30	150	110	19	8.66	A2320X	AN20	
	71	130	20	–	100	21320RHK + H320X	30	150	107	7	10.4	A320X	AN20	
	97	130	20	–	100	22320RHRK + H2320X	30	150	110	7	16.6	A2320X	AN20	
100	81	145	21	–	110	23122RHK + H3122X	32	170	117	7	7.62	A3122X	AN22	
	77	145	21	–	110	22222RHRK + H322X	32	170	117	6	10.4	A322X	AN22	
	105	145	21	–	110	23222RHK + H2322X	32	170	121	17	12.1	A2322X	AN22	
	77	145	21	–	110	21322RHK + H322X	32	170	117	9	14.0	A322X	AN22	
	105	145	21	–	110	22322RHRK + H2322X	32	170	121	7	22.5	A2322X	AN22	
110	72	145	22	–	120	23024RHK + H3024	33	180	127	7	6.70	A3024	ANL24	
	88	155	22	–	120	23124RHK + H3124	33	180	128	7	10.2	A3124	AN24	
	88	155	22	–	120	22224RHRK + H3124	33	180	128	11	13.0	A3124	AN24	
	112	155	22	–	120	23224RHK + H2324	33	180	131	17	14.8	A2324	AN24	
	112	155	22	–	120	22324RHRK + H2324	33	180	131	7	26.8	A2324	AN24	
115	80	155	23	–	130	23026RHK + H3026	34	190	137	8	9.97	A3026	ANL26	
	92	165	23	–	130	23126RHK + H3126	34	190	138	8	11.9	A3126	AN26	
	92	165	23	–	130	22226RHRK + H3126	34	190	138	8	16.7	A3126	AN26	
	121	165	23	–	130	23226RHK + H2326	34	190	142	21	18.1	A2326	AN26	
	121	165	23	–	130	22326RHRK + H2326	34	190	142	8	34.3	A2326	AN26	
125	82	165	24	–	140	23028RHK + H3028	36	205	147	8	10.76	A3028	ANL28	
	97	180	24	–	140	23128RHK + H3128	36	205	149	8	14.5	A3128	AN28	
	97	180	24	–	140	22228RHRK + H3128	36	205	149	8	20.4	A3128	AN28	
	131	180	24	–	140	23228RHK + H2328	36	205	152	22	23.5	A2328	AN28	
	131	180	24	–	140	22328RK + H2328	36	205	152	8	41.1	A2328	AN28	
	131	180	24	–	140	22328RHK + H2328	36	205	152	8	38.3	A2328	AN28	
135	87	180	26	–	150	23030RHK + H3030	37	220	158	8	13.15	A3030	ANL30	
	111	195	26	–	150	23130RHK + H3130	37	220	160	8	21.0	A3130	AN30	
	111	195	26	–	150	22230RHRK + H3130	37	220	160	15	25.7	A3130	AN30	
	139	195	26	–	150	23230RHK + H2330	37	220	163	20	29.9	A2330	AN30	
	139	195	26	–	150	22330RK + H2330	37	220	163	8	49.3	A2330	AN30	
139	195	26	–	150	22330RHAK + H2330	37	220	163	8	46.0	A2330	AN30		
140	93	190	28	–	160	23032RHK + H3032	39	230	168	8	16.2	A3032	ANL32	
	119	210	28	–	160	23132RHK + H3132	39	230	170	8	27.6	A3132	AN32	
	119	210	28	–	160	22232RK + H3132	39	230	170	14	30.5	A3132	AN32	
	119	210	28	–	160	22232RHAK + H3132	39	230	170	14	29.1	A3132	AN32	
	147	210	28	–	160	23232RK + H2332	39	230	174	18	39.2	A2332	AN32	
	147	210	28	–	160	23232RHAK + H2332	39	230	174	18	37.6	A2332	AN32	
	147	210	28	–	160	22332RK + H2332	39	230	174	8	60.1	A2332	AN32	
	147	210	28	–	160	22332RHAK + H2332	39	230	174	8	56.2	A2332	AN32	
	150	101	200	29	–	170	23034RHK + H3034	40	250	179	8	21.5	A3034	ANL34
		122	220	29	–	170	23134RHK + H3134	40	250	180	8	29.2	A3134	AN34
122		220	29	–	170	22234RK + H3134	40	250	180	10	36.8	A3134	AN34	

Adapter assemblies for spherical roller bearings

d_1 (150) – 180 mm

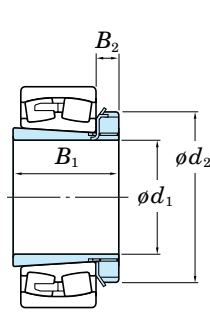

$d_1 \leq 180$ mm

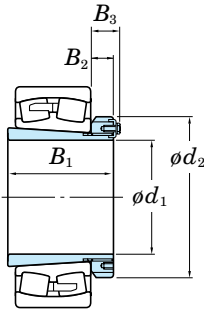

$d_1 \geq 200$ mm

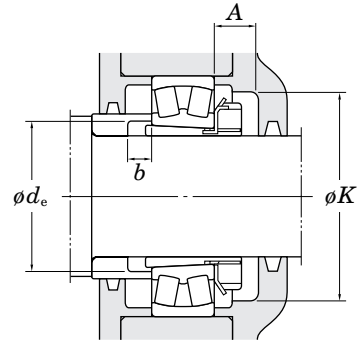

Boundary dimensions (mm)					Brg. bore (mm) <i>d</i>	Designations Bearing + adapter ass'y	Mounting dimensions (mm)				Mass Brg. + adapter ass'y (kg)	(Refer.)		
d_1	B_1	d_2	B_2	B_3			<i>A</i> min.	<i>K</i> min.	d_e min.	<i>b</i> min.		Adapter sleeve No.	Locknut No.	
150	122	220	29	–	170	22234RHAK + H3134	40	250	180	10	34.9	A3134	AN34	
	154	220	29	–	170	23234RK + H2334	40	250	185	18	46.7	A2334	AN34	
	154	220	29	–	170	23234RHAK + H2334	40	250	185	18	44.8	A2334	AN34	
	154	220	29	–	170	22334RK + H2334	40	250	185	8	71.0	A2334	AN34	
	154	220	29	–	170	22334RHAK + H2334	40	250	185	8	66.3	A2334	AN34	
	160	109	210	30	–	180	23036RHK + H3036	41	260	189	8	26.5	A3036	ANL36
131		230	30	–	180	23136RK + H3136	41	260	191	8	37.0	A3136	AN36	
131		230	30	–	180	23136RHAK + H3136	41	260	191	8	35.1	A3136	AN36	
131		230	30	–	180	22236RK + H3136	41	260	191	18	39.3	A3136	AN36	
131		230	30	–	180	22236RHAK + H3136	41	260	191	18	37.3	A3136	AN36	
161		230	30	–	180	23236RK + H2336	41	260	195	22	49.9	A2336	AN36	
161		230	30	–	180	23236RHAK + H2336	41	260	195	22	47.8	A2336	AN36	
161		230	30	–	180	22336RK + H2336	41	260	195	8	81.2	A2336	AN36	
161		230	30	–	180	22336RHAK + H2336	41	260	195	8	75.8	A2336	AN36	
170		112	220	31	–	190	23038RK + H3038	43	270	199	9	25.7	A3038	ANL38
	112	220	31	–	190	23038RHAK + H3038	43	270	199	9	24.1	A3038	ANL38	
	141	240	31	–	190	23138RK + H3138	43	270	202	9	45.2	A3138	AN38	
	141	240	31	–	190	23138RHAK + H3138	43	270	202	9	42.9	A3138	AN38	
	141	240	31	–	190	22238RK + H3138	43	270	202	21	47.4	A3138	AN38	
	141	240	31	–	190	22238RHAK + H3138	43	270	202	21	44.9	A3138	AN38	
	169	240	31	–	190	23238RK + H2338	43	270	206	21	58.6	A2338	AN38	
	169	240	31	–	190	23238RHAK + H2338	43	270	206	21	56.1	A2338	AN38	
	169	240	31	–	190	22338RK + H2338	43	270	206	9	95.0	A2338	AN38	
	169	240	31	–	190	22338RHAK + H2338	43	270	206	9	88.6	A2338	AN38	
	180	120	240	32	–	200	23040RK + H3040	46	280	210	10	32.6	A3040	ANL40
		120	240	32	–	200	23040RHAK + H3040	46	280	210	10	30.5	A3040	ANL40
150		250	32	–	200	23140RK + H3140	46	280	212	10	54.5	A3140	AN40	
150		250	32	–	200	23140RHAK + H3140	46	280	212	10	51.6	A3140	AN40	
150		250	32	–	200	22240RK + H3140	46	280	212	24	56.1	A3140	AN40	
150		250	32	–	200	22240RHAK + H3140	46	280	212	24	53.1	A3140	AN40	
176		250	32	–	200	23240RK + H2340	46	280	216	20	70.3	A2340	AN40	
176		250	32	–	200	23240RHAK + H2340	46	280	216	20	67.3	A2340	AN40	
176		250	32	–	200	22340RK + H2340	46	280	216	10	107	A2340	AN40	
176		250	32	–	200	22340RHAK + H2340	46	280	216	10	100	A2340	AN40	

d_1 200 – 280 mm

Boundary dimensions (mm)					Brg. bore (mm) d	Designations Bearing + adapter ass'y	Mounting dimensions (mm)				Mass Brg. + adapter ass'y (kg)	(Refer.)		
d_1	B_1	d_2	B_2	B_3			A min.	K min.	d_e min.	b min.		Adapter sleeve No.	Locknut No.	
200	128	260	30	41	220	23044RK + H3044	–	–	231	12	40.9	A3044	ANL44	
	128	260	30	41	220	23044RHAK + H3044	–	–	231	12	38.2	A3044	ANL44	
	158	280	32	44	220	23144RK + H3144	–	–	233	10	67.9	A3144	AN44	
	158	280	32	44	220	23144RHAK + H3144	–	–	233	10	64.3	A3144	AN44	
	158	280	32	44	220	22244RK + H3144	–	–	233	22	76.4	A3144	AN44	
	158	280	32	44	220	22244RHAK + H3144	–	–	233	22	72.2	A3144	AN44	
	183	280	32	44	220	23244RK + H2344	–	–	236	11	95.9	A2344	AN44	
	183	280	32	44	220	23244RHAK + H2344	–	–	236	11	91.7	A2344	AN44	
	183	280	32	44	220	22344RK + H2344	–	–	236	10	139	A2344	AN44	
	183	280	32	44	220	22344RHAK + H2344	–	–	236	10	130	A2344	AN44	
	220	133	290	34	46	240	23048RK + H3048	–	–	251	11	47.0	A3048	ANL48
		133	290	34	46	240	23048RHAK + H3048	–	–	251	11	44.1	A3048	ANL48
		169	300	34	46	240	23148RK + H3148	–	–	254	11	82.9	A3148	AN48
		169	300	34	46	240	23148RHAK + H3148	–	–	254	11	78.4	A3148	AN48
		169	300	34	46	240	22248RK + H3148	–	–	254	19	101	A3148	AN48
169		300	34	46	240	22248RHAK + H3148	–	–	254	19	94.9	A3148	AN48	
196		300	34	46	240	23248RK + H2348	–	–	257	6	127	A2348	AN48	
196		300	34	46	240	23248RHAK + H2348	–	–	257	6	121	A2348	AN48	
196		300	34	46	240	22348RK + H2348	–	–	257	11	174	A2348	AN48	
196		300	34	46	240	22348RHAK + H2348	–	–	257	11	162	A2348	AN48	
240		147	310	34	46	260	23052RK + H3052	–	–	272	13	64.6	A3052	ANL52
		147	310	34	46	260	23052RHAK + H3052	–	–	272	13	60.2	A3052	ANL52
		187	330	36	49	260	23152RK + H3152	–	–	276	11	113	A3152	AN52
		187	330	36	49	260	23152RHAK + H3152	–	–	276	11	107	A3152	AN52
		187	330	36	49	260	22252RK + H3152	–	–	276	25	130	A3152	AN52
	187	330	36	49	260	22252RHAK + H3152	–	–	276	25	123	A3152	AN52	
	208	330	36	49	260	23252RK + H2352	–	–	278	2	164	A2352	AN52	
	208	330	36	49	260	23252RHAK + H2352	–	–	278	2	157	A2352	AN52	
	208	330	36	49	260	22352RK + H2352	–	–	278	11	216	A2352	AN52	
	208	330	36	49	260	22352RHAK + H2352	–	–	278	11	201	A2352	AN52	
	260	152	330	38	50	280	23056RK + H3056	–	–	292	12	70.6	A3056	ANL56
		152	330	38	50	280	23056RHAK + H3056	–	–	292	12	65.9	A3056	ANL56
		192	350	38	51	280	23156RK + H3156	–	–	296	12	121	A3156	AN56
		192	350	38	51	280	23156RHAK + H3156	–	–	296	12	115	A3156	AN56
		192	350	38	51	280	22256RK + H3156	–	–	296	28	137	A3156	AN56
192		350	38	51	280	22256RHAK + H3156	–	–	296	28	129	A3156	AN56	
221		350	38	51	280	23256RK + H2356	–	–	299	11	177	A2356	AN56	
221		350	38	51	280	23256RHAK + H2356	–	–	299	11	169	A2356	AN56	
221		350	38	51	280	22356RK + H2356	–	–	299	12	253	A2356	AN56	
221		350	38	51	280	22356RHAK + H2356	–	–	299	12	236	A2356	AN56	
280		168	360	42	54	300	23060RK + H3060	–	–	313	12	96.5	A3060	ANL60
		168	360	42	54	300	23060RHAK + H3060	–	–	313	12	89.6	A3060	ANL60
		208	380	40	53	300	23160RK + H3160	–	–	317	12	158	A3160	AN60
		208	380	40	53	300	23160RHAK + H3160	–	–	317	12	149	A3160	AN60
		208	380	40	53	300	22260RK + H3160	–	–	317	32	172	A3160	AN60
	208	380	40	53	300	22260RHAK + H3160	–	–	317	32	162	A3160	AN60	
	240	380	40	53	300	23260RK + H3260	–	–	321	12	226	A3260	AN60	
	240	380	40	53	300	23260RHAK + H3260	–	–	321	12	216	A3260	AN60	

KOYO



Thrust ball bearings

Thrust ball bearings are divided into single and double direction types. The former is able to accommodate axial load in one direction, while the latter is able to accommodate it in both directions.

Neither is suitable for applications that involve radial load or high-speed rotation.

Thrust ball bearings

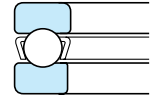

Bore diameter **10 – 200 mm**

Boundary dimensions	As specified in JIS B 1512.																				
Tolerances	As specified in JIS B 1514.																				
Standard cages	<ul style="list-style-type: none"> • Pressed steel cage (supplementary code : //) • Copper alloy or carbon steel machined cage (supplementary code : FY or FC) • Polyamide resin molded cage (supplementary code : MG) <p>Application of standard cages</p> <table border="1"> <thead> <tr> <th>Bearing series</th> <th>Molded cage</th> <th>Pressed cage</th> <th>Machined cage</th> </tr> </thead> <tbody> <tr> <td>511</td> <td>51100 - 51107</td> <td>51108 - 51132</td> <td>51134 - 51172</td> </tr> <tr> <td>512</td> <td>51200 - 51207</td> <td>51208 - 51224</td> <td>51226 - 51272</td> </tr> <tr> <td>513</td> <td>–</td> <td>51305 - 51313</td> <td>51314 - 51340</td> </tr> <tr> <td>514</td> <td>–</td> <td>51405 - 51414</td> <td>–</td> </tr> </tbody> </table>	Bearing series	Molded cage	Pressed cage	Machined cage	511	51100 - 51107	51108 - 51132	51134 - 51172	512	51200 - 51207	51208 - 51224	51226 - 51272	513	–	51305 - 51313	51314 - 51340	514	–	51405 - 51414	–
Bearing series	Molded cage	Pressed cage	Machined cage																		
511	51100 - 51107	51108 - 51132	51134 - 51172																		
512	51200 - 51207	51208 - 51224	51226 - 51272																		
513	–	51305 - 51313	51314 - 51340																		
514	–	51405 - 51414	–																		
Required minimum axial load	A certain degree of load is necessary in order for bearings to operate satisfactorily.																				
Allowable misalignment	Misalignment not allowed. (for flat back face type)																				
Equivalent axial load	Dynamic equivalent axial load $P_a = F_a$ Static equivalent axial load $P_{0a} = F_a$																				

Thrust ball bearings

d 10 – 45 mm

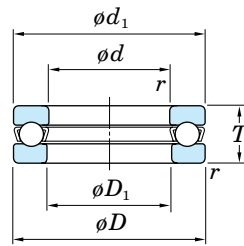

Boundary dimensions (mm)				Basic load ratings (kN)		Limiting speeds (min ⁻¹)		Bearing No.	Dimensions (mm)		(Refer.) Mass (kg)
d	D	T	r min.	C_a	C_{0a}	Grease lub.	Oil lub.		d_1 max.	D_1 min.	
10	24	9	0.3	10.0	14.0	6 500	10 000	51100 51200	24	11	0.020
	26	11	0.6	12.7	17.1	5 700	8 800		26	12	0.030
12	26	9	0.3	9.65	14.0	6 500	10 000	51101 51201	26	13	0.022
	28	11	0.6	13.2	19.0	5 400	8 300		28	14	0.034
15	28	9	0.3	9.95	15.4	6 100	9 400	51102 51202	28	16	0.024
	32	12	0.6	16.6	24.8	4 900	7 500		32	17	0.046
17	30	9	0.3	10.8	18.2	6 100	9 400	51103 51203	30	18	0.028
	35	12	0.6	17.2	27.3	4 900	7 500		35	19	0.053
20	35	10	0.3	14.2	24.7	5 100	7 900	51104 51204	35	21	0.040
	40	14	0.6	22.3	37.7	3 900	6 000		40	22	0.082
25	42	11	0.6	19.5	37.2	4 400	6 800	51105 51205 51305	42	26	0.059
	47	15	0.6	27.8	50.4	3 600	5 500		47	27	0.120
	52	18	1	35.7	61.4	3 100	4 800		52	27	0.180
30	60	24	1	55.6	89.4	2 600	4 000	51405 51106 51206 51306 51406	60	27	0.340
	47	11	0.6	20.4	42.2	4 300	6 600		47	32	0.068
	52	16	0.6	29.4	58.2	3 400	5 200		52	32	0.150
	60	21	1	42.8	78.7	2 700	4 200		60	32	0.270
35	70	28	1	72.8	126	2 200	3 400	51407 51107 51207 51307 51407	70	32	0.530
	52	12	0.6	21.2	47.2	3 900	6 000		52	37	0.090
	62	18	1	39.2	78.2	2 900	4 500		62	37	0.220
	68	24	1	55.5	105	2 400	3 700		68	37	0.390
40	80	32	1.1	87.1	155	1 900	2 900	51408 51108 51208 51308 51408	80	37	0.790
	60	13	0.6	26.9	62.8	3 400	5 300		60	42	0.120
	68	19	1	47.0	98.3	2 700	4 200		68	42	0.270
	78	26	1	69.3	135	2 100	3 300		78	42	0.550
45	90	36	1.1	113	205	1 700	2 600	51409 51109 51209 51309 51409	90	42	1.14
	65	14	0.6	27.8	69.1	3 200	5 000		65	47	0.150
	73	20	1	47.7	105	2 600	4 000		73	47	0.320
	85	28	1	80.0	163	1 900	3 000		85	47	0.690
	100	39	1.1	130	242	1 500	2 300	51409	100	47	1.47

Remark) Standard cage types used for the above bearings are described earlier in this section.

d 50 – 120 mm

<i>d</i>	Boundary dimensions (mm)			Basic load ratings (kN)		Limiting speeds (min ⁻¹)		Bearing No.	Dimensions (mm)		(Refer.) Mass (kg)
	<i>D</i>	<i>T</i>	<i>r</i> min.	<i>C_a</i>	<i>C_{0a}</i>	Grease lub.	Oil lub.		<i>d</i> ₁ max.	<i>D</i> ₁ min.	
50	70	14	0.6	28.8	75.4	3 100	4 800	51110	70	52	0.160
	78	22	1	48.5	111	2 300	3 600	51210	78	52	0.390
	95	31	1.1	96.6	202	1 800	2 700	51310	95	52	1.00
	110	43	1.5	148	283	1 400	2 100	51410	110	52	1.99
55	78	16	0.6	34.8	93.1	2 800	4 300	51111	78	57	0.240
	90	25	1	69.4	159	2 100	3 200	51211	90	57	0.610
	105	35	1.1	119	246	1 600	2 400	51311	105	57	1.34
	120	48	1.5	180	349	1 200	1 900	51411	120	57	2.64
60	85	17	1	41.4	113	2 600	4 000	51112	85	62	0.290
	95	26	1	73.6	179	1 900	3 000	51212	95	62	0.690
	110	35	1.1	124	267	1 500	2 300	51312	110	62	1.43
	130	51	1.5	214	437	1 100	1 700	51412	130	62	3.51
65	90	18	1	41.7	117	2 400	3 700	51113	90	67	0.340
	100	27	1	74.9	189	1 900	2 900	51213	100	67	0.770
	115	36	1.1	128	287	1 400	2 200	51313	115	67	1.57
	140	56	2	232	493	1 000	1 600	51413	140	68	4.47
70	95	18	1	43.1	127	2 300	3 600	51114	95	72	0.360
	105	27	1	76.1	199	1 800	2 800	51214	105	72	0.810
	125	40	1.1	134	291	1 300	2 000	51314	125	72	2.06
	150	60	2	250	553	940	1 450	51414	150	73	5.48
75	100	19	1	44.4	136	2 200	3 400	51115	100	77	0.420
	110	27	1	77.4	209	1 800	2 700	51215	110	77	0.860
	135	44	1.5	154	339	1 200	1 900	51315	135	77	2.68
80	105	19	1	44.7	141	2 100	3 300	51116	105	82	0.430
	115	28	1	78.5	218	1 700	2 600	51216	115	82	0.950
	140	44	1.5	160	368	1 200	1 800	51316	140	82	2.82
85	110	19	1	45.9	150	2 100	3 200	51117	110	87	0.460
	125	31	1	95.4	264	1 500	2 300	51217	125	88	1.29
	150	49	1.5	186	419	1 100	1 700	51317	150	88	3.66
90	120	22	1	59.7	190	1 900	2 900	51118	120	92	0.680
	135	35	1.1	117	326	1 400	2 100	51218	135	93	1.77
	155	50	1.5	193	454	1 000	1 600	51318	155	93	3.88
100	135	25	1	85.0	268	1 600	2 500	51120	135	102	0.990
	150	38	1.1	147	410	1 200	1 900	51220	150	103	2.36
	170	55	1.5	226	556	940	1 450	51320	170	103	5.11
110	145	25	1	87.1	288	1 600	2 400	51122	145	112	1.08
	160	38	1.1	153	451	1 200	1 800	51222	160	113	2.57
	190	63	2	267	704	810	1 250	51322	187	113	7.72
120	155	25	1	89.0	308	1 500	2 300	51124	155	122	1.16
	170	39	1.1	154	472	1 100	1 700	51224	170	123	2.86
	210	70	2.1	311	869	710	1 100	51324	205	123	10.6

Remark) Standard cage types used for the above bearings are described earlier in this section.

Thrust ball bearings

d 130 – 200 mm

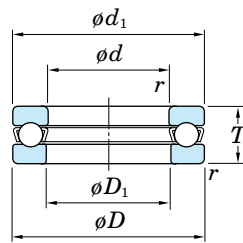

Boundary dimensions (mm)				Basic load ratings (kN)		Limiting speeds (min ⁻¹)		Bearing No.	Dimensions (mm)		(Refer.) Mass (kg)
d	D	T	r min.	C_a	C_{0a}	Grease lub.	Oil lub.		d_1 max.	D_1 min.	
130	170	30	1	104	352	1 300	2 000	51126	170	132	1.87
	190	45	1.5	191	566	970	1 500	51226	187	133	4.09
	225	75	2.1	330	958	650	1 000	51326	220	134	13.0
140	180	31	1	107	377	1 200	1 900	51128	178	142	2.02
	200	46	1.5	187	566	940	1 450	51228	197	143	4.46
	240	80	2.1	350	1 050	620	950	51328	235	144	15.5
150	190	31	1	109	402	1 200	1 900	51130	188	152	2.15
	215	50	1.5	213	652	840	1 300	51230	212	153	5.64
	250	80	2.1	361	1 130	580	900	51330	245	154	16.3
160	200	31	1	112	427	1 200	1 800	51132	198	162	2.28
	225	51	1.5	223	718	810	1 250	51232	222	163	6.53
	270	87	3	410	1 340	550	850	51332	265	164	21.0
170	215	34	1.1	131	496	1 100	1 700	51134	213	172	3.25
	240	55	1.5	261	834	750	1 150	51234	237	173	8.12
	280	87	3	463	1 570	520	800	51334	275	174	22.0
180	225	34	1.1	129	496	1 000	1 600	51136	222	183	3.39
	250	56	1.5	265	874	710	1 100	51236	247	183	8.68
	300	95	3	463	1 580	490	750	51336	295	184	28.1
190	240	37	1.1	163	616	970	1 500	51138	237	193	3.95
	270	62	2	308	1 060	650	1 000	51238	267	194	11.7
	320	105	4	543	1 950	440	680	51338	315	195	36.0
200	250	37	1.1	168	657	940	1 450	51140	247	203	4.13
	280	62	2	314	1 110	620	950	51240	277	204	12.2
	340	110	4	596	2 220	420	650	51340	335	205	42.9

Remark) Standard cage types used for the above bearings are described earlier in this section.

KOYO



Spherical thrust roller bearings

Spherical thrust roller bearings are designed to carry high axial loads. They can also support radial load if magnitude is no more than 55% of the axial load being carried.

These bearings are not suitable for high-speed rotation.

Having a spherical housing washer raceway surface, these bearings are self-aligning, adjusting to axial inclination.

They are usually used with oil lubrication.

Spherical thrust roller bearings

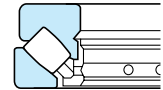

Bore diameter **60 – 300 mm**

Boudary dimensions	As specified in JIS B 1512.
Tolerances	As specified in JIS B 1514, class 0.
Required minimum axial load	A certain degree of load is necessary in order for bearings to operate satisfactorily.
Standard cage	Copper alloy machined cage (supplementary code : FY)
Allowable aligning angle	0.035 – 0.052 rad (2° – 3°) in general, depending on bearing series.
Equivalent axial load	Dynamic equivalent axial load $P_a = 1.2F_r + F_a$ Static equivalent axial load $P_{0a} \doteq 2.7F_r + F_a$ (Note : $F_r / F_a \leq 0.55$)

Spherical thrust roller bearings

d 60 – 180 mm

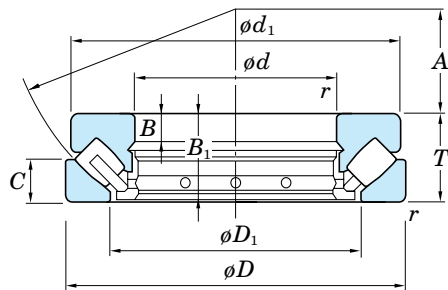

Boundary dimensions (mm)				Basic load ratings (kN)		Limiting speeds (min ⁻¹)	Bearing No.	Dimensions (mm)					(Refer.) Mass (kg)	
d	D	T	$r_{\min.}$	C_a	C_{0a}	Oil lub.		d_1	D_1	B	B_1	C	A	
60	130	42	1.5	319	884	2 700	29412R	123	89	15	39.5	20	38	2.61
65	140	45	2	360	1 020	2 500	29413R	133	96	16	42.5	21	42	3.34
70	150	48	2	387	1 100	2 300	29414R	142	103	17	45.5	23	44	4.06
75	160	51	2	468	1 360	2 100	29415R	152	109	18	48	24	47	4.76
80	170	54	2.1	505	1 480	2 000	29416R	162	117	19	51	26	50	5.91
85	150	39	1.5	321	1 000	2 600	29317R	143.5	114	13	37	19	50	2.82
	180	58	2.1	572	1 700	1 900	29417R	170	125	21	55	28	54	7.04
90	155	39	1.5	330	1 050	2 500	29318R	148.5	117	13	37	19	52	3.06
	190	60	2.1	658	2 010	1 800	29418R	180	132	22	57	29	56	8.18
100	170	42	1.5	385	1 270	2 300	29320R	163	129	14	40	20.8	58	3.81
	210	67	3	730	2 220	1 650	29420R	200	146	24	64	32	62	11.2
110	190	48	2	502	1 690	2 000	29322R	182	143	16	45.5	23	64	5.56
	230	73	3	896	2 810	1 500	29422R	220	162	26	69	35	69	14.7
120	210	54	2.1	608	2 050	1 800	29324R	200	159	18	51	26	70	7.63
	250	78	4	1 090	3 450	1 350	29424R	236	174	29	74	37	74	18.2
130	225	58	2.1	715	2 440	1 700	29326R	215	171	19	55	28	76	9.43
	270	85	4	1 200	3 850	1 250	29426R	255	189	31	81	41	81	22.8
140	240	60	2.1	744	2 590	1 600	29328R	230	183	20	57	29	82	11.1
	280	85	4	1 250	4 060	1 250	29428R	268	199	31	81	41	86	24.6
150	250	60	2.1	798	2 880	1 550	29330R	240	194	20	57	29	87	11.6
	300	90	4	1 390	4 640	1 100	29430R	285	214	32	86	44	92	29.9
160	270	67	3	956	3 430	1 400	29332R	260	208	23	64	32	92	15.4
	320	95	5	1 590	5 340	1 050	29432R	306	229	34	91	45	99	36.2
170	280	67	3	981	3 590	1 350	29334R	270	216	23	64	32	96	16.2
	340	103	5	1 750	5 900	950	29434R	324	243	37	99	50	104	44.3
180	300	73	3	1 100	4 000	1 250	29336R	290	232	25	69	35	103	20.7
	360	109	5	2 060	7 000	900	29436R	342	255	39	105	52	110	52.6

d 190 – 300 mm

Boundary dimensions (mm)				Basic load ratings (kN)		Limiting speeds (min ⁻¹)	Bearing No.	Dimensions (mm)						(Refer.) Mass
<i>d</i>	<i>D</i>	<i>T</i>	<i>r</i> min.	<i>C</i> _a	<i>C</i> _{0a}	Oil lub.		<i>d</i> ₁	<i>D</i> ₁	<i>B</i>	<i>B</i> ₁	<i>C</i>	<i>A</i>	(kg)
190	320	78	4	1 250	4 610	1 150	29338R 29438R	308	246	27	74	38	110	25.1
	380	115	5	2 240	7 720	850		360	271	41	111	55	117	60.7
200	340	85	4	1 440	5 340	1 050	29340R 29440R	325	261	29	81	41	116	31.2
	400	122	5	2 460	8 470	800		380	286	43	117	59	122	72.2
220	360	85	4	1 510	5 830	1 000	29344R 29444R	345	280	29	81	41	125	33.3
	420	122	6	2 540	8 990	750		400	308	43	117	58	132	74.9
240	380	85	4	1 520	5 990	950	29348R 29448R	365	300	29	81	41	135	35.5
	440	122	6	2 610	9 510	700		420	326	43	117	59	142	80.0
260	420	95	5	1 930	7 610	850	29352R 29452R	405	329	32	91	45	148	49.1
	480	132	6	3 120	11 700	650		460	357	48	127	64	154	104
280	440	95	5	2 000	8 110	800	29356R 29456R	423	348	32	91	46	158	53.2
	520	145	6	3 650	13 600	550		495	387	52	140	68	166	134
300	480	109	5	2 490	10 200	700	29360R 29460R	460	379	37	105	50	168	74.9
	540	145	6	3 880	14 900	550		515	402	52	140	70	175	142

KOYO



Ball bearing units

Ball bearing units consist of pre-lubricated sealed ball bearings and a housing which varies in shape.

They are capable of aligning themselves efficiently using the spherical fitting surface between the bearing and housing, effectively preventing overloads due to misalignment.

Koyo ball bearing units are highly accurate and feature excellent load resistance. They are completely sealed, and provided with a relubrication feature.

Ball bearing units without a relubrication feature are also available.

Pillow block type

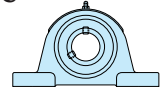

Bore diameter 12 – 140 mm

Flanged type

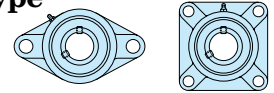

Bore diameter 12 – 140 mm

Flanged type with spigot joint

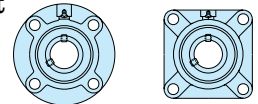

Bore diameter 12 – 140 mm

Take-up type

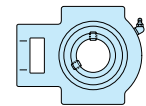

Bore diameter 12 – 140 mm

Cartridge type

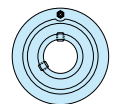

Bore diameter 12 – 65 mm

Light duty units



Bore diameter 12 – 40 mm

"Clean" series (made from light alloy)



Bore diameter 10 – 30 mm

Pressed steel housing units

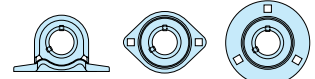

Bore diameter 12 – 35 mm

Ball bearings for units

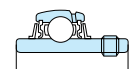







Bore diameter 10 – 140 mm

Ball bearing units

Major ball bearing unit types

(1) Cast iron units

	Pillow block type ● UCP 2-X-3 ▲ UKP 2-X-3
	Rhombic-flanged type ● UCFL 2-X-3 ▲ UKFL 2-X-3
	Square-flanged type ● UCF 2-X-3 ▲ UKF 2-X-3
	Round-flanged type with spigot joint ● UCFC 2-X ▲ UKFC 2-X
	Square-flanged type with spigot joint ● UCFS 3 ▲ UKFS 3
	Take-up type ● UCT 2-X-3 ▲ UKT 2-X-3
	Cartridge type ● UCC 2 ▲ UKC 2

Special pillow block type



● UCPH 2 ● UCFA 2

Thick section pillow block type



● UCIP 2-3
▲ UKIP 2-3

Flanged type variations





● UCFA 2 ● UCFB 2

Hanger type





● UCHA 2



(2) Light duty units (cast iron)

Pillow block type  ● BLP 2	Rhombic-flanged type  ● BLF 2
--	--



(3) "Clean" series units (special light alloy)

Pillow block type  ● UP 0	Rhombic-flanged type  ● UFL 0
---	--



(4) Pressed steel housing units

		
● SBPP 2	● SBPFL 2	● SBPF 2

(5) Take-up units with frame

	
● UCTH 2	● UCTL 2 ● UCTU 2-3

(6) Ball bearings for units

	Cylindrical bore type (set screw locking) ● UC 2-X-3 ● SU 0 ● SB 2
	Tapered bore type (adapter locking) ● UK 2-X-3

Notes) This catalogue includes the specifications of major units and bearings which are boxed in the table.

Marks ● : set screw locking, ▲ : adapter locking

Tolerances	<ul style="list-style-type: none"> • Ball bearings as specified in JIS B 1558 (Tables 1 and 2). • Housings as specified in JIS B 1559. <div style="text-align: center; border-left: 1px solid black; border-right: 1px solid black; padding: 0 10px; margin-left: 100px;"> the internal spherical diameter tolerance is given in Table 3. </div>
Bearing radial internal clearance	<p>As specified in JIS B 1520 (Table 2-1 on p. A 11).</p> <p>Koyo provides cylindrical bore bearings with normal radial internal clearance. Tapered bore bearings are provided with a C3 radial internal clearance in consideration of possible inner ring expansion caused by tightening of an adapter.</p>
Recommended fits of inner ring and shaft (indicated by the tolerance class)	<ul style="list-style-type: none"> • Cylindrical bore bearings h6, h7, h8, j6 (k6, k7 and m6 when heavy or impact load is to be supported.) • Tapered bore bearings h8, h9 • High-speed blower bearings (S5) h5, j5
Rotation speed limits	See Table 4.
Allowable aligning angle	• 0.052 rad (3°)

Ball bearing units

Table 1 Ball bearings for units : inner ring tolerance

Unit μm

Nominal bore diameter d (mm)		Bore diameter						Single inner (outer) ring width deviation $\Delta B_s (\Delta C_s)$		Radial runout of assembled bearing inner ring K_{in}
		UC, SU and SB types			Bearings for blower (S5)					
		Single plane mean bore diameter deviation Δd_{mp}		Single radial plane bore diameter variation Vd_p	Single plane mean bore diameter deviation Δd_{mp}		Single radial plane bore diameter variation Vd_p			
over	up to	upper	lower	max.	upper	lower	max.	upper	lower	max.
10 more	18	+15	0	10	+13	0	6	0	-120	15
18	31.75	+18	0	12	+13	0	6	0	-120	18
31.75	50.8	+21	0	14	+13	0	10	0	-120	20
50.8	80	+24	0	16	+15	0	10	0	-150	25
80	120	+28	0	19	+18	0	14	0	-200	30
120	180	+33	0	22	+23	0	14	0	-250	35

Table 2 Ball bearings for units : outer ring tolerance

Unit μm

Nominal outside diameter D (mm)		Mean outside diameter deviation ΔD_m		Radial runout of assembled bearing outer ring K_{ea}
		upper	lower	
over	up to			max.
18	30	0	-9	15
30	50	0	-11	20
50	80	0	-13	25
80	120	0	-15	35
120	150	0	-18	40
150	180	0	-25	45
180	250	0	-30	50
250	315	0	-35	60

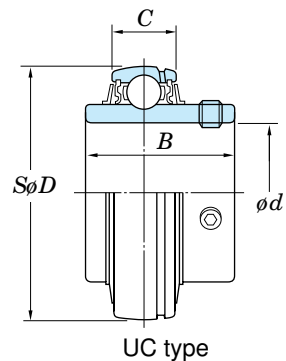

Note) The lower value of mean outside diameter deviation does not apply to the sides of outer rings up to the extent of a quarter of the outer ring width from the side faces.

Table 3 Housing spherical bore diameter tolerance

Unit μm

Nominal spherical bore diameter D_a (mm)		Tolerance class H7		Tolerance class J7		Tolerance class K7		All tolerance classes	
		Single plane mean spherical bore diameter deviation ΔD_{amp}		Single plane mean spherical bore diameter deviation ΔD_{amp}		Single plane mean spherical bore diameter deviation ΔD_{amp}		Single radial plane spherical bore diameter variation Vd_p	
		upper	lower	upper	lower	upper	lower	max.	
18	30	+21	0	+12	-9	+6	-15	8	
30	50	+25	0	+14	-11	+7	-18	10	
50	80	+30	0	+18	-12	+9	-21	12	
80	120	+35	0	+22	-13	+10	-25	14	
120	180	+40	0	+26	-14	+12	-28	16	
180	250	+46	0	+30	-16	+13	-33	18	
250	315	+52	0	+36	-16	+16	-36	20	

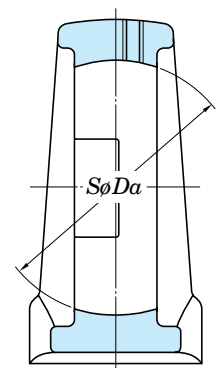

Remark) Koyo generally applies class J to housing designs.

Class H and class K and also be applied depending on the application.

Table 4 Rotation speed limits of ball bearing units

 Unit μm

Bore diameter No.	Standard			Triple lip sealed (L3)			For high speed rotation (K3 and S5)			Heat resistant type B (D1K2)
	Diameter series			Diameter series			Diameter series			Diameter series
	2	X	3	2	X	3	2	X	3	2, X, 3
01	5 800			2 300			8 700			3 800
02	5 800			2 300			8 700			3 800
03	5 800			2 300			8 700			3 800
04	5 800			2 300			8 700			3 800
05	5 100	4 300	4 600	2 100	960		7 700	6 400	6 700	3 000
06	4 300	3 700	3 900	960	830		6 400	5 500	5 800	2 500
07	3 700	3 300	3 400	830	750	770	5 500	5 000	5 100	2 100
08	3 300	3 100	3 100	750	690	690	5 000	4 600	4 600	1 900
09	3 100	2 800	2 700	690	640	620	4 600	4 300	4 100	1 700
10	2 800	2 500	2 400	640	570	550	4 300	3 800	3 700	1 500
11	2 500	2 300	2 300	570	520	510	3 800	3 500	3 400	1 400
12	2 300	2 200	2 100	520	490	470	3 500	3 200	3 100	1 300
13	2 200	2 100	1 900	490	460	440	3 200	3 100	2 900	1 200
14	2 100	2 000	1 800	460	440	410	3 100	2 900	2 700	1 100
15	2 000	1 800	1 700	440	410	380	2 900	2 700	2 600	1 000
16	1 800	1 700	1 600	410	380	360	2 700	2 600	2 400	940
17	1 700	1 600	1 500	380	360	340	2 600	2 400	2 300	880
18	1 600	1 500	1 400	360	340	320	2 400	2 300	2 100	830
19		—	1 400		—	310		—	2 000	790
20		1 300	1 300		300	280		2 000	1 900	750
21			1 200			—			1 800	710
22			1 100			250			1 700	680
24			1 100			240			1 600	630
26			1 000			220			1 500	580
28			910			200			1 400	540

- Remarks) 1. Cold-resistant types (D2K2) and heat-resistant types A (D3K2) feature the same level of rotation speed limits as the standard type.
2. Refer to a separate catalog for details of triple lip sealed bearings, high-speed bearings (K3 and S5) and heat-resistant bearings (D1K2 and D3K2).
3. When bearings are fit loosely, rotation speed limits should be compensated for by the fitting coefficient given below.

Bearing type	Fitting coefficient					
	Shaft tolerance class					
	h 5, js 5	h 6	h 7	h 8	h 9	j 6
Standard	—	1	0.8	0.5	0.2	1
Triple lip sealed (L3)	—	—	1	1	0.9	—
For high speed rotation (K3)	—	0.8	0.6	—	—	1
For blower (S5)	1	0.8	0.6	—	—	—
Heat-resistant type B (D1K2)	—	—	1	1	0.7	—

Ball bearing units pillow block type UCP (set screw locking) d 12 – 55 mm

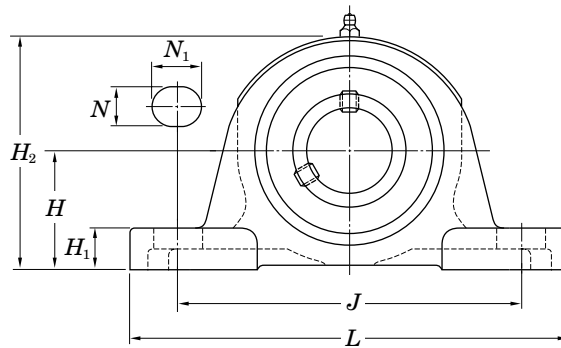
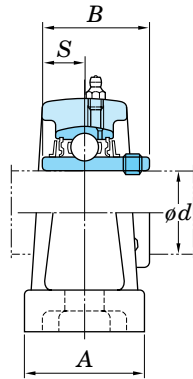

Shaft dia. (mm) d	Dimensions (mm)										Bolt size	Unit No.	Housing No.	Applicable bearing Basic load ratings (kN)		(Refer.) Unit Mass (kg)	
	H	J	L	A	H_1	H_2	N	N_1	B	S				No.	C_r		C_{0r}
12	30.2	95	127	38	12	60	13	18	31	12.7	M10	UCP201	P203	UC201	12.8	6.65	0.63
15	30.2	95	127	38	12	60	13	18	31	12.7	M10	UCP202	P203	UC202	12.8	6.65	0.61
17	30.2	95	127	38	12	60	13	18	31	12.7	M10	UCP203	P203	UC203	12.8	6.65	0.60
20	33.3	95	127	38	13	64	13	18	31	12.7	M10	UCP204	P204	UC204	12.8	6.65	0.66
25	36.5	105	140	38	13	71	13	18	34.1	14.3	M10	UCP205	P205	UC205	14.0	7.85	0.80
	44.4	119	159	51	16	86	17	25	38.1	15.9	M14	UCPX05	PX05	UCX05	19.5	11.3	1.5
	45	132	175	45	16	85	17	20	38	15	M14	UCP305	P305	UC305	20.6	11.3	1.7
30	42.9	121	165	48	15	84	17	21	38.1	15.9	M14	UCP206	P206	UC206	19.5	11.3	1.3
	47.6	127	175	57	17	93	17	25	42.9	17.5	M14	UCPX06	PX06	UCX06	25.7	15.4	2.1
	50	140	180	50	17	95	17	20	43	17	M14	UCP306	P306	UC306	26.7	15.0	2.2
35	47.6	127	167	48	16	93	17	21	42.9	17.5	M14	UCP207	P207	UC207	25.7	15.4	1.6
	54	144	203	57	19	105	17	30	49.2	19	M14	UCPX07	PX07	UCX07	29.1	17.8	2.7
	56	160	210	56	19	107	17	25	48	19	M14	UCP307	P307	UC307	33.4	19.3	3.0
40	49.2	137	184	54	17	98	17	21	49.2	19	M14	UCP208	P208	UC208	29.1	17.8	2.0
	58.7	156	222	67	21	114	20	32	49.2	19	M16	UCPX08	PX08	UCX08	32.7	20.3	3.5
	60	170	220	60	19	118	17	27	52	19	M14	UCP308	P308	UC308	40.7	24.0	3.8
45	54	146	190	54	17	106	17	21	49.2	19	M14	UCP209	P209	UC209	32.7	20.3	2.2
	58.7	156	222	67	21	116	20	33	51.6	19	M16	UCPX09	PX09	UCX09	35.1	23.3	3.7
	67	190	245	67	21	132	20	30	57	22	M16	UCP309	P309	UC309	48.9	29.5	4.9
50	57.2	159	206	60	19	113	20	22	51.6	19	M16	UCP210	P210	UC210	35.1	23.3	2.9
	63.5	171	241	73	22	126	20	36	55.6	22.2	M16	UCPX10	PX10	UCX10	43.4	29.4	4.6
	75	212	275	75	24	148	20	35	61	22	M16	UCP310	P310	UC310	62.0	38.3	6.6
55	63.5	171	219	60	19	125	20	22	55.6	22.2	M16	UCP211	P211	UC211	43.4	29.4	3.6
	69.8	184	260	79	28	139	25	36	65.1	25.4	M20	UCPX11	PX11	UCX11	52.4	36.2	6.5
	80	236	310	80	27	158	20	38	66	25	M16	UCP311	P311	UC311	71.6	45.0	7.9

Remarks 1) Applicable sizes of grease nipples are shown below.

{ 1/4-28UNF 201 – 210, X05 – X09, 305 – 308 }
 { PT 1/8 211 – 218, X10 – X20, 309 – 328 }

2) For bearings with double- or triple-lip seals, unit and bearing number are suffixed by L2 or L3.
(For more detailed information, refer to ball bearing for unit specification tables.)

d 60 – 140 mm

Shaft dia. (mm)	Dimensions (mm)										Bolt size	Unit No.	Housing No.	Applicable bearing		(Refer.) Unit Mass (kg)	
	<i>d</i>	<i>H</i>	<i>J</i>	<i>L</i>	<i>A</i>	<i>H</i> ₁	<i>H</i> ₂	<i>N</i>	<i>N</i> ₁	<i>B</i>				<i>S</i>	No.		Basic load ratings (kN) <i>C</i> _r <i>C</i> _{0r}
60	69.8	184	241	70	22	138	20	25	65.1	25.4	M16	UCP212 UCPX12 UCP312	P212 PX12 P312	UC212	52.4	36.2	4.9
	76.2	203	286	83	28	152	25	40	65.1	25.4	M20			UCX12	57.2	40.1	7.7
	85	250	330	85	29	167	25	38	71	26	M20			UC312	81.9	52.2	9.5
65	76.2	203	265	70	25	150	25	30	65.1	25.4	M20	UCP213 UCPX13 UCP313	P213 PX13 P313	UC213	57.2	40.1	5.9
	76.2	203	286	83	28	155	25	40	74.6	30.2	M20			UCX13	62.2	44.1	8.1
	90	260	340	90	32	176	25	38	75	30	M20			UC313	92.7	59.9	10.7
70	79.4	210	266	72	28	156	25	30	74.6	30.2	M20	UCP214 UCPX14 UCP314	P214 PX14 P314	UC214	62.2	44.1	6.8
	88.9	229	330	89	32	171	27	50	77.8	33.3	M22			UCX14	67.4	48.3	10.2
	95	280	360	90	35	186	27	40	78	33	M22			UC314	104	68.2	12.4
75	82.6	217	275	74	28	162	25	30	77.8	33.3	M20	UCP215 UCPX15 UCP315	P215 PX15 P315	UC215	67.4	48.3	7.4
	88.9	229	330	89	32	175	27	50	82.6	33.3	M22			UCX15	72.7	53.0	10.8
	100	290	380	100	35	198	27	40	82	32	M22			UC315	113	77.2	14.8
80	88.9	232	292	78	32	174	25	35	82.6	33.3	M20	UCP216 UCPX16 UCP316	P216 PX16 P316	UC216	72.7	53.0	9.0
	101.6	283	381	102	34	195	27	58	85.7	34.1	M22			UCX16	84.0	61.9	15.3
	106	300	400	110	35	209	27	40	86	34	M22			UC316	123	86.7	18.5
85	95.2	247	310	83	32	185	25	40	85.7	34.1	M20	UCP217 UCPX17 UCP317	P217 PX17 P317	UC217	84.0	61.9	10.8
	101.6	283	381	102	34	200	27	60	96	39.7	M22			UCX17	96.1	71.5	16.1
	112	320	420	110	40	220	33	45	96	40	M27			UC317	133	96.8	20.3
90	101.6	262	327	88	34	198	27	45	96	39.7	M22	UCP218 UCPX18 UCP318	P218 PX18 P318	UC218	96.1	71.5	13.9
	101.6	283	381	111	38	204	27	60	104	42.9	M22			UCX18	109	81.9	19.1
	118	330	430	110	40	234	33	45	96	40	M27			UC318	143	107	22.8
95	125	360	470	120	46	248	36	50	103	41	M30	UCP319	P319	UC319	153	119	29.0
100	127	337	432	121	45	245	33	65	117.5	49.2	M27	UCPX20 UCP320	PX20 P320	UCX20	133	105	30.4
	140	380	490	120	46	273	36	50	108	42	M30			UC320	173	141	35.1
105	140	380	490	120	46	278	36	50	112	44	M30	UCP321	P321	UC321	184	153	37.6
110	150	400	520	140	50	296	40	55	117	46	M33	UCP322	P322	UC322	205	180	44.0
120	160	450	570	140	50	316	40	55	126	51	M33	UCP324	P324	UC324	207	185	55.4
130	180	480	600	140	50	355	40	55	135	54	M33	UCP326	P326	UC326	229	214	72.1
140	200	500	620	140	60	393	40	55	145	59	M33	UCP328	P328	UC328	253	246	92.5

Remarks 1) Applicable sizes of grease nipples are shown below.

1/4-28UNF	201 – 210, X05 – X09, 305 – 308
PT 1/8	211 – 218, X10 – X20, 309 – 328

2) For bearings with double- or triple-lip seals, unit and bearing number are suffixed by L2 or L3.
(For more detailed information, refer to ball bearing for unit specification tables.)

Ball bearing units pillow block type UKP (adapter locking) d 20 – 60 mm

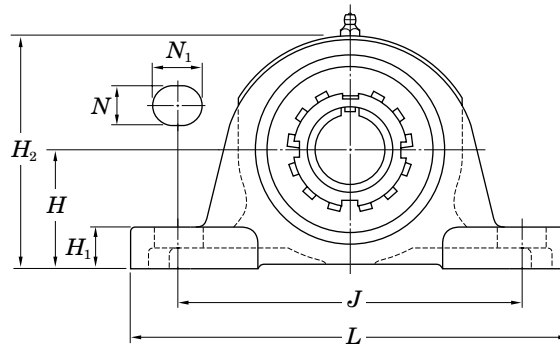
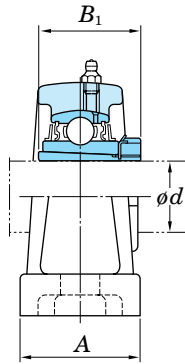

Shaft dia. (mm) d	Dimensions (mm)									Bolt size	Unit No.	Housing No.	Applicable bearing Basic load ratings (kN)		(Refer.) Unit Mass (kg)	
	H	J	L	A	H_1	H_2	N	N_1	B_1				No.	C_r		C_{or}
20	36.5	105	140	38	13	71	13	18	29	M10	UKP205	P205	UK205	14.0	7.85	0.84
	44.4	119	159	51	16	86	17	25	35	M14	UKPX05	PX05	UKX05	19.5	11.3	1.5
	45	132	175	45	16	85	17	20	35	M14	UKP305	P305	UK305	20.6	11.3	1.7
25	42.9	121	165	48	15	84	17	21	31	M14	UKP206	P206	UK206	19.5	11.3	1.4
	47.6	127	175	57	17	93	17	25	38	M14	UKPX06	PX06	UKX06	25.7	15.4	2.1
	50	140	180	50	17	95	17	20	38	M14	UKP306	P306	UK306	26.7	15.0	2.3
30	47.6	127	167	48	16	93	17	21	35	M14	UKP207	P207	UK207	25.7	15.4	1.7
	54	144	203	57	19	105	17	30	43	M14	UKPX07	PX07	UKX07	29.1	17.8	2.7
	56	160	210	56	19	107	17	25	43	M14	UKP307	P307	UK307	33.4	19.3	3.0
35	49.2	137	184	54	17	98	17	21	36	M14	UKP208	P208	UK208	29.1	17.8	2.0
	58.7	156	222	67	21	114	20	32	46	M16	UKPX08	PX08	UKX08	32.7	20.3	3.5
	60	170	220	60	19	118	17	27	46	M14	UKP308	P308	UK308	40.7	24.0	3.8
40	54	146	190	54	17	106	17	21	39	M14	UKP209	P209	UK209	32.7	20.3	2.3
	58.7	156	222	67	21	116	20	33	50	M16	UKPX09	PX09	UKX09	35.1	23.3	3.7
	67	190	245	67	21	132	20	30	50	M16	UKP309	P309	UK309	48.9	29.5	5.0
45	57.2	159	206	60	19	113	20	22	42	M16	UKP210	P210	UK210	35.1	23.3	3.0
	63.5	171	241	73	22	126	20	36	55	M16	UKPX10	PX10	UKX10	43.4	29.4	4.6
	75	212	275	75	24	148	20	35	55	M16	UKP310	P310	UK310	62.0	38.3	6.7
50	63.5	171	219	60	19	125	20	22	45	M16	UKP211	P211	UK211	43.4	29.4	3.7
	69.8	184	260	79	28	139	25	36	59	M20	UKPX11	PX11	UKX11	52.4	36.2	6.2
	80	236	310	80	27	158	20	38	59	M16	UKP311	P311	UK311	71.6	45.0	8.1
55	69.8	184	241	70	22	138	20	25	47	M16	UKP212	P212	UK212	52.4	36.2	4.8
	76.2	203	286	83	28	152	25	40	62	M20	UKPX12	PX12	UKX12	57.2	40.1	7.5
	85	250	330	85	29	167	25	38	62	M20	UKP312	P312	UK312	81.9	52.2	9.4
60	76.2	203	265	70	25	150	25	30	50	M20	UKP213	P213	UK213	57.2	40.1	5.8
	76.2	203	286	83	28	155	25	40	65	M20	UKPX13	PX13	UKX13	62.2	44.1	7.8
	90	260	340	90	32	176	25	38	65	M20	UKP313	P313	UK313	92.7	59.9	10.8

Remark) Applicable sizes of grease nipples are shown below.

1/4-28UNF 205 – 210, X05 – X09, 305 – 308
 PT 1/8 211 – 218, X10 – X20, 309 – 328

d 65 – 125 mm

Shaft dia. (mm) <i>d</i>	Dimensions (mm)									Bolt size	Unit No.	Housing No.	Applicable bearing		(Refer.) Unit Mass (kg)	
	<i>H</i>	<i>J</i>	<i>L</i>	<i>A</i>	<i>H</i> ₁	<i>H</i> ₂	<i>N</i>	<i>N</i> ₁	<i>B</i> ₁				No.	Basic load ratings (kN) <i>C</i> _r <i>C</i> _{0r}		
65	82.6	217	275	74	28	162	25	30	55	M20	UKP215	P215	UK215	67.4	48.3	7.5
	88.9	229	330	89	32	175	27	50	73	M22	UKPX15	PX15	UKX15	72.7	53.0	10.5
	100	290	380	100	35	198	27	40	73	M22	UKP315	P315	UK315	113	77.2	14.9
70	88.9	232	292	78	32	174	25	35	59	M20	UKP216	P216	UK216	72.7	53.0	9.2
	101.6	283	381	102	34	195	27	58	78	M22	UKPX16	PX16	UKX16	84.0	61.9	15.4
	106	300	400	110	35	209	27	40	78	M22	UKP316	P316	UK316	123	86.7	18.6
75	95.2	247	310	83	32	185	25	40	63	M20	UKP217	P217	UK217	84.0	61.9	11.0
	101.6	283	381	102	34	200	27	60	82	M22	UKPX17	PX17	UKX17	96.1	71.5	15.8
	112	320	420	110	40	220	33	45	82	M27	UKP317	P317	UK317	133	96.8	20.2
80	101.6	262	327	88	34	198	27	45	65	M22	UKP218	P218	UK218	96.1	71.5	13.8
	101.6	283	381	111	38	204	27	60	86	M22	UKPX18	PX18	UKX18	109	81.9	18.6
	118	330	430	110	40	234	33	45	86	M27	UKP318	P318	UK318	143	107	22.8
85	125	360	470	120	46	248	36	50	90	M30	UKP319	P319	UK319	153	119	29.3
90	127	337	432	121	45	245	33	65	97	M27	UKPX20	PX20	UKX20	133	105	29.3
	140	380	490	120	46	273	36	50	97	M30	UKP320	P320	UK320	173	141	34.8
100	150	400	520	140	50	296	40	55	105	M33	UKP322	P322	UK322	205	180	43.9
110	160	450	570	140	50	316	40	55	112	M33	UKP324	P324	UK324	207	185	55.7
115	180	480	600	140	50	355	40	55	121	M33	UKP326	P326	UK326	229	214	71.9
125	200	500	620	140	60	393	40	55	131	M33	UKP328	P328	UK328	253	246	92.5

Remark) Applicable sizes of grease nipples are shown below.
 { 1/4-28UNF 205 – 210, X05 – X09, 305 – 308 }
 { PT 1/8 211 – 218, X10 – X20, 309 – 328 }

Ball bearing units
thick section pillow block type
UCIP (set screw locking)
 d 40 – 140 mm

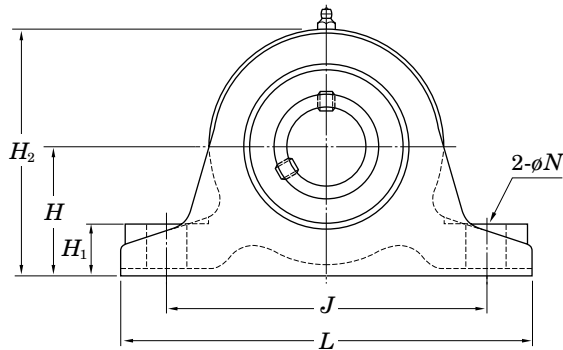
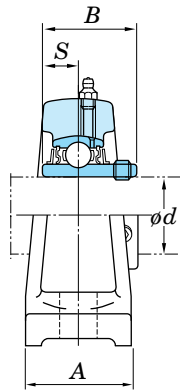

Shaft dia. (mm) d	Dimensions (mm)									Bolt size	Unit No.	Housing No.	Applicable bearing No.	Applicable bearing Basic load ratings (kN)		(Refer.) Unit Mass (kg)
	H	J	L	A	H_1	H_2	N	B	S					C_r	C_{0r}	
40	60	150	200	60	25	115	19	49.2	19	M16	UCIP208	IP208	UC208	29.1	17.8	3.4
45	70	160	210	60	25	128	19	49.2	19	M16	UCIP209	IP209	UC209	32.7	20.3	3.9
50	70	170	220	60	28	132	19	51.6	19	M16	UCIP210	IP210	UC210	35.1	23.3	4.8
55	80	180	230	60	28	148	19	55.6	22.2	M16	UCIP211	IP211	UC211	43.4	29.4	5.3
60	80	200	260	70	30	155	22	65.1	25.4	M20	UCIP212	IP212	UC212	52.4	36.2	7.2
65	90	220	280	70	30	172	22	65.1	25.4	M20	UCIP213	IP213	UC213	57.2	40.1	8.8
	110	250	310	70	30	208	22	75	30	M20	UCIP313	IP313	UC313	92.7	59.9	13.4
70	110	270	330	75	35	215	25	78	33	M22	UCIP314	IP314	UC314	104	68.2	15.3
75	120	280	340	75	35	230	25	82	32	M22	UCIP315	IP315	UC315	113	77.2	17.6
80	120	290	350	85	40	235	25	86	34	M22	UCIP316	IP316	UC316	123	86.7	20.3
85	130	310	370	85	40	255	25	96	40	M22	UCIP317	IP317	UC317	133	96.8	25.9
90	130	330	400	85	45	260	29	96	40	M27	UCIP318	IP318	UC318	143	107	28.6
95	150	340	410	85	45	285	29	103	41	M27	UCIP319	IP319	UC319	153	119	31.7
100	150	360	430	85	45	295	29	108	42	M27	UCIP320	IP320	UC320	173	141	36.9
110	170	410	490	100	50	335	32	117	46	M30	UCIP322	IP322	UC322	205	180	52.4
120	170	430	510	100	50	345	32	126	51	M30	UCIP324	IP324	UC324	207	185	58.7
130	200	470	550	110	50	390	32	135	54	M30	UCIP326	IP326	UC326	229	214	76.2
140	200	500	590	110	55	400	35	145	59	M33	UCIP328	IP328	UC328	253	246	87.0

Remarks 1) Applicable sizes of grease nipples are shown below.

- 1/4-28UNF 208 – 210
- PT 1/8 211 – 213, 313 – 328

2) Bearings with triple-lip seals are indicated by L3 after the bearing and unit number.
 (For more detailed information, refer to ball bearing for unit specification tables.)

Ball bearing units
rhombic-flanged type
UCFL (set screw locking)
 d 12 – 60 mm

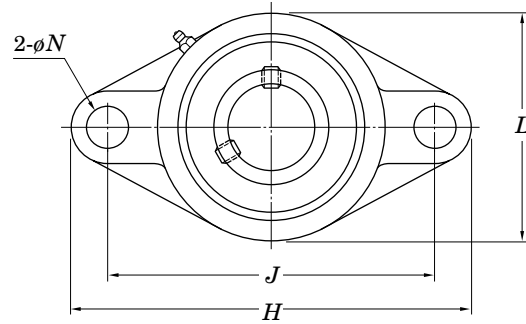
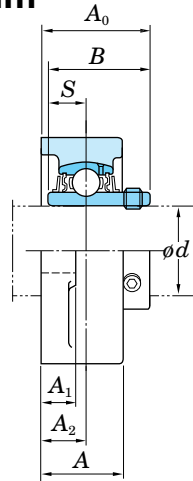

Shaft dia. (mm) d	Dimensions (mm)											Bolt size	Unit No.	Housing No.	Applicable bearing No.		Basic load ratings (kN)		(Refer.) Unit Mass (kg)
	H	J	L	A	A_1	A_2	A_0	N	B	S	C_r				C_{0r}				
12	113	90	60	25.5	11	15	33.3	12	31	12.7	M10	UCFL201	FL204	UC201	12.8	6.65	0.50		
15	113	90	60	25.5	11	15	33.3	12	31	12.7	M10	UCFL202	FL204	UC202	12.8	6.65	0.48		
17	113	90	60	25.5	11	15	33.3	12	31	12.7	M10	UCFL203	FL204	UC203	12.8	6.65	0.47		
20	113	90	60	25.5	11	15	33.3	12	31	12.7	M10	UCFL204	FL204	UC204	12.8	6.65	0.45		
25	130	99	68	27	13	16	35.8	16	34.1	14.3	M14	UCFL205	FL205	UC205	14.0	7.85	0.64		
	141	117	83	30	13	18	40.2	12	38.1	15.9	M10	UCFLX05	FLX05	UCX05	19.5	11.3	1.1		
	150	113	80	29	13	16	39	19	38	15	M16	UCFL305	FL305	UC305	20.6	11.3	1.1		
30	148	117	80	31	13	18	40.2	16	38.1	15.9	M14	UCFL206	FL206	UC206	19.5	11.3	0.93		
	156	130	95	34	14	19	44.4	16	42.9	17.5	M14	UCFLX06	FLX06	UCX06	25.7	15.4	1.5		
	180	134	90	32	15	18	44	23	43	17	M20	UCFL306	FL306	UC306	26.7	15.0	1.5		
35	161	130	90	34	14	19	44.4	16	42.9	17.5	M14	UCFL207	FL207	UC207	25.7	15.4	1.2		
	171	144	105	38	14	21	51.2	16	49.2	19	M14	UCFLX07	FLX07	UCX07	29.1	17.8	1.9		
	185	141	100	36	16	20	49	23	48	19	M20	UCFL307	FL307	UC307	33.4	19.3	1.8		
40	175	144	100	36	14	21	51.2	16	49.2	19	M14	UCFL208	FL208	UC208	29.1	17.8	1.6		
	179	148	111	40	14	22	52.2	16	49.2	19	M14	UCFLX08	FLX08	UCX08	32.7	20.3	2.1		
	200	158	112	40	17	23	56	23	52	19	M20	UCFL308	FL308	UC308	40.7	24.0	2.5		
45	188	148	108	38	15	22	52.2	19	49.2	19	M16	UCFL209	FL209	UC209	32.7	20.3	1.9		
	189	157	116	40	14	23	55.6	16	51.6	19	M14	UCFLX09	FLX09	UCX09	35.1	23.3	2.4		
	230	177	125	44	18	25	60	25	57	22	M22	UCFL309	FL309	UC309	48.9	29.5	3.5		
50	197	157	115	40	15	22	54.6	19	51.6	19	M16	UCFL210	FL210	UC210	35.1	23.3	2.2		
	216	184	133	44	20	26	59.4	19	55.6	22.2	M16	UCFLX10	FLX10	UCX10	43.4	29.4	3.8		
	240	187	140	48	19	28	67	25	61	22	M22	UCFL310	FL310	UC310	62.0	38.3	4.4		
55	224	184	130	43	18	25	58.4	19	55.6	22.2	M16	UCFL211	FL211	UC211	43.4	29.4	3.3		
	250	198	150	52	20	30	71	25	66	25	M22	UCFL311	FL311	UC311	71.6	45.0	5.3		
60	250	202	140	48	18	29	68.7	23	65.1	25.4	M20	UCFL212	FL212	UC212	52.4	36.2	4.2		
	270	212	160	56	22	33	78	31	71	26	M27	UCFL312	FL312	UC312	81.9	52.2	6.5		

Remarks 1) Applicable sizes of grease nipples are shown below.

1/4-28UNF	201 – 210, X05 – X09, 305 – 308
PT 1/8	211 – 218, X10, 309 – 318

2) For bearings with double- or triple-lip seals, unit and bearing number are suffixed by L2 or L3.
 (For more detailed information, refer to ball bearing for unit specification tables.)

d 65 – 90 mm

Shaft dia. (mm)	Dimensions (mm)										Bolt size	Unit No.	Housing No.	Applicable bearing			(Refer.) Unit Mass (kg)
	<i>d</i>	<i>H</i>	<i>J</i>	<i>L</i>	<i>A</i>	<i>A</i> ₁	<i>A</i> ₂	<i>A</i> ₀	<i>N</i>	<i>B</i>				<i>S</i>	No.	Basic load ratings (kN)	
														<i>C</i> _r	<i>C</i> _{0r}		
65	258	210	155	50	20	30	69.7	23	65.1	25.4	M20	UCFL213 UCFL313	FL213 FL313	UC213 UC313	57.2	40.1	5.1
	295	240	175	58	25	33	78	31	75	30	M27				92.7	59.9	8.5
70	265	216	160	54	20	31	75.4	23	74.6	30.2	M20	UCFL214 UCFL314	FL214 FL314	UC214 UC314	62.2	44.1	5.7
	315	250	185	61	28	36	81	35	78	33	M30				104	68.2	9.7
75	275	225	165	56	20	34	78.5	23	77.8	33.3	M20	UCFL215 UCFL315	FL215 FL315	UC215 UC315	67.4	48.3	6.4
	320	260	195	66	30	39	89	35	82	32	M30				113	77.2	11.3
80	290	233	180	58	20	34	83.3	25	82.6	33.3	M22	UCFL216 UCFL316	FL216 FL316	UC216 UC316	72.7	53.0	7.8
	355	285	210	68	32	38	90	38	86	34	M33				123	86.7	14.4
85	305	248	190	63	22	36	87.6	25	85.7	34.1	M22	UCFL217 UCFL317	FL217 FL317	UC217 UC317	84.0	61.9	9.8
	370	300	220	74	32	44	100	38	96	40	M33				133	96.8	16.0
90	320	265	205	68	23	40	96.3	25	96	39.7	M22	UCFL218 UCFL318	FL218 FL318	UC218 UC318	96.1	71.5	12.3
	385	315	235	76	36	44	100	38	96	40	M33				143	107	19.0

Remarks 1) Applicable sizes of grease nipples are shown below.

1/4-28UNF	201 – 210, X05 – X09, 305 – 308
PT 1/8	211 – 218, X10, 309 – 318

- 2) For bearings with double- or triple-lip seals, unit and bearing number are suffixed by L2 or L3.
(For more detailed information, refer to ball bearing for unit specification tables.)

Ball bearing units square-flanged type UCF (set screw locking) d 12 – 55 mm

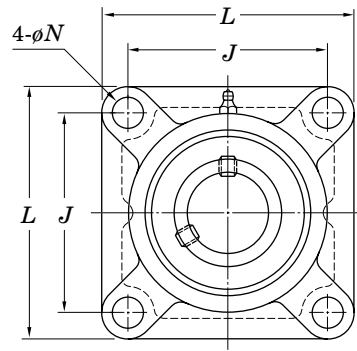
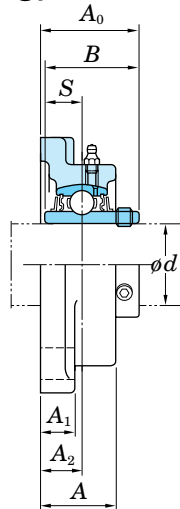

Shaft dia. (mm) d	Dimensions (mm)									Bolt size	Unit No.	Housing No.	Applicable bearing No.		Basic load ratings (kN)		(Refer.) Unit Mass (kg)
	J	L	A	A_1	A_2	A_0	N	B	S				C_r	C_{or}			
12	64	86	25.5	11	15	33.3	12	31	12.7	M10	UCF201	F204	UC201	12.8	6.65	0.64	
15	64	86	25.5	11	15	33.3	12	31	12.7	M10	UCF202	F204	UC202	12.8	6.65	0.62	
17	64	86	25.5	11	15	33.3	12	31	12.7	M10	UCF203	F204	UC203	12.8	6.65	0.61	
20	64	86	25.5	11	15	33.3	12	31	12.7	M10	UCF204	F204	UC204	12.8	6.65	0.59	
25	70	95	27	13	16	35.8	12	34.1	14.3	M10	UCF205	F205	UC205	14.0	7.85	0.83	
	83	108	30	13	18	40.2	12	38.1	15.9	M10	UCFX05	FX05	UCX05	19.5	11.3	1.2	
	80	110	29	13	16	39	16	38	15	M14	UCF305	F305	UC305	20.6	11.3	1.3	
30	83	108	31	13	18	40.2	12	38.1	15.9	M10	UCF206	F206	UC206	19.5	11.3	1.1	
	92	117	34	14	19	44.4	16	42.9	17.5	M14	UCFX06	FX06	UCX06	25.7	15.4	1.6	
	95	125	32	15	18	44	16	43	17	M14	UCF306	F306	UC306	26.7	15.0	1.9	
35	92	117	34	15	19	44.4	14	42.9	17.5	M12	UCF207	F207	UC207	25.7	15.4	1.5	
	102	130	38	14	21	51.2	16	49.2	19	M14	UCFX07	FX07	UCX07	29.1	17.8	2.0	
	100	135	36	16	20	49	19	48	19	M16	UCF307	F307	UC307	33.4	19.3	2.3	
40	102	130	36	15	21	51.2	16	49.2	19	M14	UCF208	F208	UC208	29.1	17.8	1.9	
	105	137	40	14	22	52.2	19	49.2	19	M16	UCFX08	FX08	UCX08	32.7	20.3	2.4	
	112	150	40	17	23	56	19	52	19	M16	UCF308	F308	UC308	40.7	24.0	3.1	
45	105	137	38	16	22	52.2	16	49.2	19	M14	UCF209	F209	UC209	32.7	20.3	2.2	
	111	143	40	14	23	55.6	19	51.6	19	M16	UCFX09	FX09	UCX09	35.1	23.3	2.7	
	125	160	44	18	25	60	19	57	22	M16	UCF309	F309	UC309	48.9	29.5	4.0	
50	111	143	40	16	22	54.6	16	51.6	19	M14	UCF210	F210	UC210	35.1	23.3	2.5	
	130	162	44	20	26	59.4	19	55.6	22.2	M16	UCFX10	FX10	UCX10	43.4	29.4	3.7	
	132	175	48	19	28	67	23	61	22	M20	UCF310	F310	UC310	62.0	38.3	5.1	
55	130	162	43	18	25	58.4	19	55.6	22.2	M16	UCF211	F211	UC211	43.4	29.4	3.4	
	143	175	49	20	29	68.7	19	65.1	25.4	M16	UCFX11	FX11	UCX11	52.4	36.2	4.9	
	140	185	52	20	30	71	23	66	25	M20	UCF311	F311	UC311	71.6	45.0	5.6	

Remarks 1) Applicable sizes of grease nipples are shown below.

1/4-28UNF	201 – 210, X05 – X09, 305 – 308
PT 1/8	211 – 218, X10 – X20, 309 – 328

2) For bearings with double- or triple-lip seals, unit and bearing number are suffixed by L2 or L3.
(For more detailed information, refer to ball bearing for unit specification tables.)

d 60 – 140 mm

Shaft dia. (mm) <i>d</i>	Dimensions (mm)									Bolt size	Unit No.	Housing No.	Applicable bearing		(Refer.) Unit Mass (kg)	
	<i>J</i>	<i>L</i>	<i>A</i>	<i>A</i> ₁	<i>A</i> ₂	<i>A</i> ₀	<i>N</i>	<i>B</i>	<i>S</i>				No.	Basic load ratings (kN) <i>C</i> _r <i>C</i> _{0r}		
60	143	175	48	18	29	68.7	19	65.1	25.4	M16	UCF212	F212	UC212	52.4	36.2	4.2
	149	187	59	21	34	73.7	19	65.1	25.4	M16	UCFX12	FX12	UCX12	57.2	40.1	5.7
	150	195	56	22	33	78	23	71	26	M20	UCF312	F312	UC312	81.9	52.2	6.9
65	149	187	50	22	30	69.7	19	65.1	25.4	M16	UCF213	F213	UC213	57.2	40.1	5.2
	149	187	59	21	34	78.4	19	74.6	30.2	M16	UCFX13	FX13	UCX13	62.2	44.1	6.3
	166	208	58	22	33	78	23	75	30	M20	UCF313	F313	UC313	92.7	59.9	7.8
70	152	193	54	22	31	75.4	19	74.6	30.2	M16	UCF214	F214	UC214	62.2	44.1	5.9
	152	197	60	22	37	81.5	23	77.8	33.3	M20	UCFX14	FX14	UCX14	67.4	48.3	7.0
	178	226	61	25	36	81	25	78	33	M22	UCF314	F314	UC314	104	68.2	10.1
75	159	200	56	22	34	78.5	19	77.8	33.3	M16	UCF215	F215	UC215	67.4	48.3	6.4
	152	197	68	24	40	89.3	23	82.6	33.3	M20	UCFX15	FX15	UCX15	72.7	53.0	8.4
	184	236	66	25	39	89	25	82	32	M22	UCF315	F315	UC315	113	77.2	11.6
80	165	208	58	22	34	83.3	23	82.6	33.3	M20	UCF216	F216	UC216	72.7	53.0	7.3
	171	214	70	24	40	91.6	23	85.7	34.1	M20	UCFX16	FX16	UCX16	84.0	61.9	9.4
	196	250	68	27	38	90	31	86	34	M27	UCF316	F316	UC316	123	86.7	12.8
85	175	220	63	24	36	87.6	23	85.7	34.1	M20	UCF217	F217	UC217	84.0	61.9	8.9
	171	214	70	24	40	96.3	23	96	39.7	M20	UCFX17	FX17	UCX17	96.1	71.5	10.8
	204	260	74	27	44	100	31	96	40	M27	UCF317	F317	UC317	133	96.8	15.3
90	187	235	68	25	40	96.3	23	96	39.7	M20	UCF218	F218	UC218	96.1	71.5	11.4
	171	214	76	24	45	106.1	23	104	42.9	M20	UCFX18	FX18	UCX18	109	81.9	11.9
	216	280	76	30	44	100	35	96	40	M30	UCF318	F318	UC318	143	107	18.9
95	228	290	94	30	59	121	35	103	41	M30	UCF319	F319	UC319	153	119	21.6
100	211	268	97	28	59	127.3	31	117.5	49.2	M27	UCFX20	FX20	UCX20	133	105	19.4
	242	310	94	32	59	125	38	108	42	M33	UCF320	F320	UC320	173	141	25.8
105	242	310	94	32	59	127	38	112	44	M33	UCF321	F321	UC321	184	153	30.2
110	266	340	96	35	60	131	41	117	46	M36	UCF322	F322	UC322	205	180	35.3
120	290	370	110	40	65	140	41	126	51	M36	UCF324	F324	UC324	207	185	47.3
130	320	410	115	45	65	146	41	135	54	M36	UCF326	F326	UC326	229	214	65.5
140	350	450	125	55	75	161	41	145	59	M36	UCF328	F328	UC328	253	246	93.4

Remarks 1) Applicable sizes of grease nipples are shown below.

1/4-28UNF	201 – 210, X05 – X09, 305 – 308
PT 1/8	211 – 218, X10 – X20, 309 – 328

2) For bearings with double- or triple-lip seals, unit and bearing number are suffixed by L2 or L3.
(For more detailed information, refer to ball bearing for unit specification tables.)

Ball bearing units

round-falnged type with spigot joint

UCFC (set screw locking)

d 12 – 70 mm

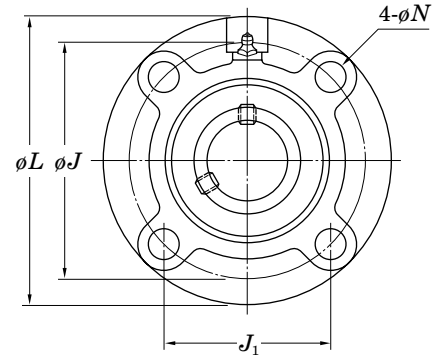
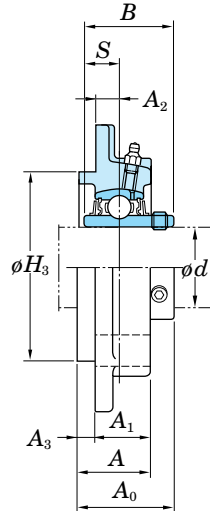

Shaft dia. (mm) d	Dimensions (mm)												Bolt size	Unit No.	Housing No.	Applicable bearing		(Refer.) Unit Mass (kg)	
	L	J	J_1	H_3	A	A_1	A_2	A_3	A_0	N	B	S				No.	Basic load ratings (kN) C_r C_{0r}		
12	100	78	55.1	62	25.5	20.5	10	5	33.3	12	31	12.7	M10	UCFC201	FC204	UC201	12.8	6.65	0.78
15	100	78	55.1	62	25.5	20.5	10	5	33.3	12	31	12.7	M10	UCFC202	FC204	UC202	12.8	6.65	0.76
17	100	78	55.1	62	25.5	20.5	10	5	33.3	12	31	12.7	M10	UCFC203	FC204	UC203	12.8	6.65	0.75
20	100	78	55.1	62	25.5	20.5	10	5	33.3	12	31	12.7	M10	UCFC204	FC204	UC204	12.8	6.65	0.73
25	115	90	63.6	70	27	21	10	6	35.8	12	34.1	14.3	M10	UCFC205	FC205	UC205	14.0	7.85	0.95
	111	92	65	76	30	24	10	6	38.2	9.5	38.1	15.9	M8	UCFCX05	FCX05	UCX05	19.5	11.3	1.2
30	125	100	70.7	80	31	23	10	8	40.2	12	38.1	15.9	M10	UCFC206	FC206	UC206	19.5	11.3	1.3
	127	105	74.2	85	32	22.5	8	9.5	42.9	12	42.9	17.5	M10	UCFCX06	FCX06	UCX06	25.7	15.4	1.5
35	135	110	77.8	90	34	26	11	8	44.4	14	42.9	17.5	M12	UCFC207	FC207	UC207	25.7	15.4	1.7
	133	111	78.5	92	37	26	9	11	50.2	12	49.2	19	M10	UCFCX07	FCX07	UCX07	29.1	17.8	1.9
40	145	120	84.8	100	36	26	11	10	51.2	14	49.2	19	M12	UCFC208	FC208	UC208	29.1	17.8	2.0
	133	111	78.5	92	37	26	9	11	50.2	12	49.2	19	M10	UCFCX08	FCX08	UCX08	32.7	20.3	2.0
45	160	132	93.3	105	38	26	10	12	52.2	16	49.2	19	M14	UCFC209	FC209	UC209	32.7	20.3	2.6
	155	130	91.9	108	37	25	8	12	52.6	14	51.6	19	M12	UCFCX09	FCX09	UCX09	35.1	23.3	2.6
50	165	138	97.6	110	40	28	10	12	54.6	16	51.6	19	M14	UCFC210	FC210	UC210	35.1	23.3	2.9
	162	136	96.2	118	41	25	7	16	56.4	14	55.6	22.2	M12	UCFCX10	FCX10	UCX10	43.4	29.4	3.2
55	185	150	106.1	125	43	31	13	12	58.4	19	55.6	22.2	M16	UCFC211	FC211	UC211	43.4	29.4	4.2
	180	152	107.5	127	48	26	4	22	65.7	16	65.1	25.4	M14	UCFCX11	FCX11	UCX11	52.4	36.2	4.3
60	195	160	113.1	135	48	36	17	12	68.7	19	65.1	25.4	M16	UCFC212	FC212	UC212	52.4	36.2	5.0
	194	165	116.7	140	53	33	11	20	70.7	16	65.1	25.4	M14	UCFCX12	FCX12	UCX12	57.2	40.1	5.3
65	205	170	120.2	145	50	36	16	14	69.7	19	65.1	25.4	M16	UCFC213	FC213	UC213	57.2	40.1	5.6
	194	165	116.7	140	53	33	11	20	75.4	16	74.6	30.2	M14	UCFCX13	FCX13	UCX13	62.2	44.1	5.7
70	215	177	125.1	150	54	40	17	14	75.4	19	74.6	30.2	M16	UCFC214	FC214	UC214	62.2	44.1	6.8
	222	190	134.3	164	56	36	14	20	78.5	19	77.8	33.3	M16	UCFCX14	FCX14	UCX14	67.4	48.3	7.3

Remarks 1) Applicable sizes of grease nipples are shown below.

$\left[\begin{array}{l} 1/4-28UNF \dots\dots 201 - 210, X05 - X09 \\ PT 1/8 \dots\dots\dots 211 - 218, X10 - X20 \end{array} \right]$

2) For bearings with double- or triple-lip seals, unit and bearing number are suffixed by L2 or L3.
(For more detailed information, refer to ball bearing for unit specification tables.)

d 75 – 100 mm

Shaft dia. (mm)	Dimensions (mm)												Bolt size	Unit No.	Housing No.	Applicable bearing		(Refer.) Unit Mass (kg)	
	<i>d</i>	<i>L</i>	<i>J</i>	<i>J</i> ₁	<i>H</i> ₃	<i>A</i>	<i>A</i> ₁	<i>A</i> ₂	<i>A</i> ₃	<i>A</i> ₀	<i>N</i>	<i>B</i>				<i>S</i>	No.		Basic load ratings (kN) <i>C</i> _r <i>C</i> _{0r}
75	220	184	130.1	160	56	40	18	16	78.5	19	77.8	33.3	M16	UCFC215 UCFCX15	FC215 FCX15	UC215 UCX15	67.4 72.7	48.3 53.0	7.2 8.0
	222	190	134.3	164	57	35	12	22	83.3	19	82.6	33.3							
80	240	200	141.4	170	58	42	18	16	83.3	23	82.6	33.3	M20	UCFC216 UCFCX16	FC216 FCX16	UC216 UCX16	72.7 84.0	53.0 61.9	8.7 11.3
	260	219	154.8	186	61	36	10	25	86.6	23	85.7	34.1	M20						
85	250	208	147.1	180	63	45	18	18	87.6	23	85.7	34.1	M20	UCFC217 UCFCX17	FC217 FCX17	UC217 UCX17	84.0 96.1	61.9 71.5	10.3 12.9
	260	219	154.8	186	61	36	10	25	91.3	23	96	39.7	M20						
90	265	220	155.5	190	68	50	22	18	96.3	23	96	39.7	M20	UCFC218 UCFCX18	FC218 FCX18	UC218 UCX18	96.1 109	71.5 81.9	13.3 13.5
	260	219	154.8	186	71	43	12	28	101.1	23	104	42.9	M20						
100	276	238	168.3	206	94	66	22	28	118.3	23	117.5	49.2	M20	UCFCX20	FCX20	UCX20	133	105	18.2

Remarks 1) Applicable sizes of grease nipples are shown below.

{
 1/4-28UNF 201 – 210, X05 – X09
 PT 1/8 211 – 218, X10 – X20

2) For bearings with double- or triple-lip seals, unit and bearing number are suffixed by L2 or L3.
(For more detailed information, refer to ball bearing for unit specification tables.)

Ball bearing units

square-flanged type with spigot joint

UCFS (set screw locking)

d 25 – 140 mm

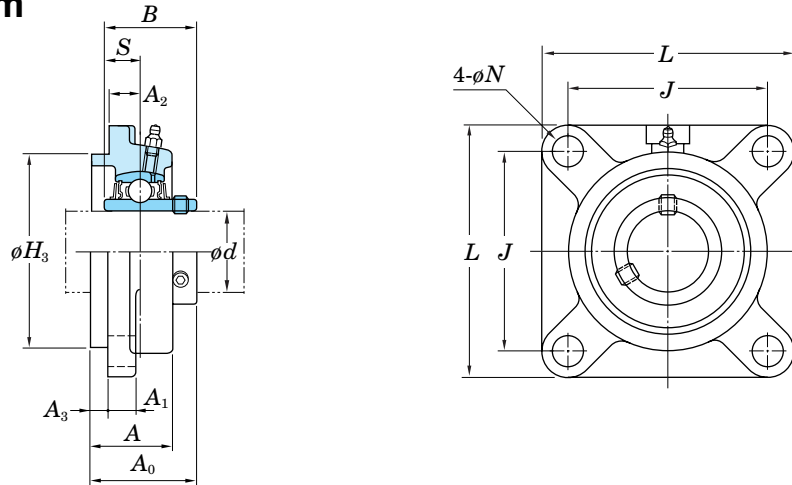

Shaft dia. (mm) d	Dimensions (mm)											Bolt size	Unit No.	Housing No.	Applicable bearing Basic load ratings (kN)		(Refer.) Unit Mass (kg)	
	J	L	H_3	A	A_1	A_2	A_3	A_0	N	B	S				C_r	C_{0r}		
25	80	110	80	29	13	9	7	39	16	38	15	M14	UCFS305	FS305	UC305	20.6	11.3	1.4
30	95	125	90	32	15	10	8	44	16	43	17	M14	UCFS306	FS306	UC306	26.7	15.0	1.9
35	100	135	100	36	16	11	9	49	19	48	19	M16	UCFS307	FS307	UC307	33.4	19.3	2.3
40	112	150	115	40	17	13	10	56	19	52	19	M16	UCFS308	FS308	UC308	40.7	24.0	3.4
45	125	160	125	44	18	14	11	60	19	57	22	M16	UCFS309	FS309	UC309	48.9	29.5	4.4
50	132	175	140	48	19	16	12	67	23	61	22	M20	UCFS310	FS310	UC310	62.0	38.3	5.3
55	140	185	150	52	20	17	13	71	23	66	25	M20	UCFS311	FS311	UC311	71.6	45.0	6.1
60	150	195	160	56	22	19	14	78	23	71	26	M20	UCFS312	FS312	UC312	81.9	52.2	7.4
65	166	208	175	58	22	15	18	78	23	75	30	M20	UCFS313	FS313	UC313	92.7	59.9	8.8
70	178	226	185	61	25	18	18	81	25	78	33	M22	UCFS314	FS314	UC314	104	68.2	11.2
75	184	236	200	66	25	21	18	89	25	82	32	M22	UCFS315	FS315	UC315	113	77.2	13.7
80	196	250	210	68	27	18	20	90	31	86	34	M27	UCFS316	FS316	UC316	123	86.7	15.1
85	204	260	220	74	27	24	20	100	31	96	40	M27	UCFS317	FS317	UC317	133	96.8	17.3
90	216	280	240	76	30	24	20	100	35	96	40	M30	UCFS318	FS318	UC318	143	107	21.3
95	228	290	250	94	30	39	20	121	35	103	41	M30	UCFS319	FS319	UC319	153	119	24.5
100	242	310	260	94	32	39	20	125	38	108	42	M33	UCFS320	FS320	UC320	173	141	29.5
105	242	310	260	94	32	39	20	127	38	112	44	M33	UCFS321	FS321	UC321	184	153	32.7
110	266	340	300	96	35	35	25	131	41	117	46	M36	UCFS322	FS322	UC322	205	180	39.0
120	290	370	330	110	40	35	30	140	41	126	51	M36	UCFS324	FS324	UC324	207	185	50.6
130	320	410	360	115	45	35	30	146	41	135	54	M36	UCFS326	FS326	UC326	229	214	67.7
140	350	450	400	125	55	45	30	161	41	145	59	M36	UCFS328	FS328	UC328	253	246	94.0

Remarks 1) Applicable sizes of grease nipples are shown below.

1/4-28UNF 305 – 308
 PT 1/8 309 – 328

2) Bearings with triple-lip seals are indicated by L3 after the bearing and unit number.
(For more detailed information, refer to ball bearing for unit specification tables.)

Ball bearing units
take-up type
UCT (set screw locking)
d 12 – 55 mm

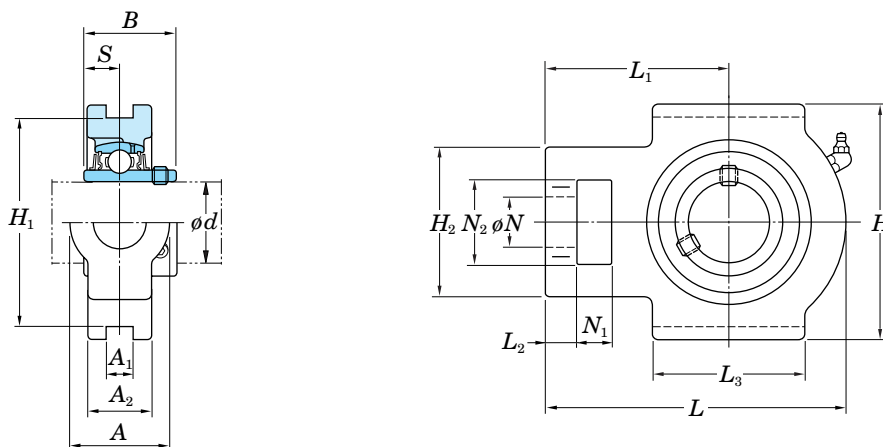

Shaft dia. (mm) <i>d</i>	Dimensions (mm)															Unit No.	Housing No.	Applicable bearing No.		Basic load ratings (kN)		(Refer.) Unit Mass (kg)
	<i>A</i>	<i>A</i> ₁	<i>A</i> ₂	<i>H</i>	<i>H</i> ₁	<i>H</i> ₂	<i>L</i>	<i>L</i> ₁	<i>L</i> ₂	<i>L</i> ₃	<i>N</i>	<i>N</i> ₁	<i>N</i> ₂	<i>B</i>	<i>S</i>			<i>C</i> _r	<i>C</i> _{0r}			
12	32	12	21	89	76	51	94	61	10	51	19	16	32	31	12.7	UCT201	T204	UC201	12.8	6.65	0.81	
15	32	12	21	89	76	51	94	61	10	51	19	16	32	31	12.7	UCT202	T204	UC202	12.8	6.65	0.79	
17	32	12	21	89	76	51	94	61	10	51	19	16	32	31	12.7	UCT203	T204	UC203	12.8	6.65	0.78	
20	32	12	21	89	76	51	94	61	10	51	19	16	32	31	12.7	UCT204	T204	UC204	12.8	6.65	0.76	
25	32	12	24	89	76	51	97	62	10	51	19	16	32	34.1	14.3	UCT205	T205	UC205	14.0	7.85	0.84	
	37	12	28	102	89	56	113	70	10	57	22	16	37	38.1	15.9	UCTX05	TX05	UCX05	19.5	11.3	1.4	
	36	12	26	89	80	62	122	76	12	65	26	16	36	38	15	UCT305	T305	UC305	20.6	11.3	1.4	
30	37	12	28	102	89	56	113	70	10	57	22	16	37	38.1	15.9	UCT206	T206	UC206	19.5	11.3	1.3	
	37	12	30	102	89	64	129	78	13	64	22	16	37	42.9	17.5	UCTX06	TX06	UCX06	25.7	15.4	1.7	
	41	16	28	100	90	70	137	85	14	74	28	18	41	43	17	UCT306	T306	UC306	26.7	15.0	1.8	
35	37	12	30	102	89	64	129	78	13	64	22	16	37	42.9	17.5	UCT207	T207	UC207	25.7	15.4	1.6	
	49	16	36	114	102	83	144	88	15	83	29	19	49	49.2	19	UCTX07	TX07	UCX07	29.1	17.8	2.7	
	45	16	32	111	100	75	150	94	15	80	30	20	45	48	19	UCT307	T307	UC307	33.4	19.3	2.3	
40	49	16	33	114	102	83	144	88	16	83	29	19	49	49.2	19	UCT208	T208	UC208	29.1	17.8	2.5	
	49	16	36	117	102	83	144	87	15	83	29	19	49	49.2	19	UCTX08	TX08	UCX08	32.7	20.3	2.6	
	50	18	34	124	112	83	162	100	17	89	32	22	50	52	19	UCT308	T308	UC308	40.7	24.0	3.0	
45	49	16	35	117	102	83	144	87	16	83	29	19	49	49.2	19	UCT209	T209	UC209	32.7	20.3	2.4	
	49	16	38	117	102	83	149	90	16	86	29	19	49	51.6	19	UCTX09	TX09	UCX09	35.1	23.3	2.9	
	55	18	38	138	125	90	178	110	18	97	34	24	55	57	22	UCT309	T309	UC309	48.9	29.5	4.1	
50	49	16	37	117	102	83	149	90	16	86	29	19	49	51.6	19	UCT210	T210	UC210	35.1	23.3	2.6	
	64	22	42	146	130	102	171	106	19	95	35	25	64	55.6	22.2	UCTX10	TX10	UCX10	43.4	29.4	4.4	
	61	20	40	151	140	98	191	117	20	106	37	27	61	61	22	UCT310	T310	UC310	62.0	38.3	4.9	
55	64	22	38	146	130	102	171	106	19	95	35	25	64	55.6	22.2	UCT211	T211	UC211	43.4	29.4	4.0	
	64	22	44	146	130	102	194	119	19	102	35	32	64	65.1	25.4	UCTX11	TX11	UCX11	52.4	36.2	5.3	
	66	22	44	163	150	105	207	127	21	115	39	29	66	66	25	UCT311	T311	UC311	71.6	45.0	6.1	

Remarks 1) Applicable sizes of grease nipples are shown below.

- 1/4-28UNF 201 – 210, X05 – X09, 305 – 308
- PT 1/8 211 – 217, X10 – X17, 309 – 328

2) For bearings with double- or triple-lip seals, unit and bearing number are suffixed by L2 or L3.
 (For more detailed information, refer to ball bearing for unit specification tables.)

d 60 – 140 mm

Shaft dia. (mm)	Dimensions (mm)															Unit No.	Housing No.	Applicable bearing		(Refer.) Unit Mass (kg)	
	<i>d</i>	A	A ₁	A ₂	H	H ₁	H ₂	L	L ₁	L ₂	L ₃	N	N ₁	N ₂	B			S	No.		Basic load ratings (kN) C _r C _{0r}
60	64	22	42	146	130	102	194	119	19	102	35	32	64	65.1	25.4	UCT212	T212	UC212	52.4	36.2	4.9
	70	26	48	167	151	111	224	137	21	121	41	32	70	65.1	25.4	UCTX12	TX12	UCX12	57.2	40.1	7.4
	71	22	46	178	160	113	220	135	23	123	41	31	71	71	26	UCT312	T312	UC312	81.9	52.2	7.6
65	70	26	44	167	151	111	224	137	21	121	41	32	70	65.1	25.4	UCT213	T213	UC213	57.2	40.1	6.9
	70	26	48	167	151	111	224	137	21	121	41	32	70	74.6	30.2	UCTX13	TX13	UCX13	62.2	44.1	7.6
	80	26	50	190	170	116	238	146	25	134	43	32	70	75	30	UCT313	T313	UC313	92.7	59.9	9.3
70	70	26	46	167	151	111	224	137	21	121	41	32	70	74.6	30.2	UCT214	T214	UC214	62.2	44.1	7.0
	70	26	48	167	151	111	232	140	21	121	41	32	70	77.8	33.3	UCTX14	TX14	UCX14	67.4	48.3	7.9
	90	26	52	202	180	130	252	155	25	140	46	36	85	78	33	UCT314	T314	UC314	104	68.2	11.1
75	70	26	48	167	151	111	232	140	21	121	41	32	70	77.8	33.3	UCT215	T215	UC215	67.4	48.3	7.3
	70	28	48	184	165	111	235	140	21	121	41	32	70	82.6	33.3	UCTX15	TX15	UCX15	72.7	53.0	8.7
	90	26	55	216	192	132	262	160	25	150	46	36	85	82	32	UCT315	T315	UC315	113	77.2	13.0
80	70	26	51	184	165	111	235	140	21	121	41	32	70	82.6	33.3	UCT216	T216	UC216	72.7	53.0	8.2
	73	28	54	198	173	124	260	162	28	157	48	38	73	85.7	34.1	UCTX16	TX16	UCX16	84.0	61.9	11.7
	102	30	60	230	204	150	282	174	28	160	53	42	98	86	34	UCT316	T316	UC316	123	86.7	16.2
85	73	30	54	198	173	124	260	162	29	157	48	38	73	85.7	34.1	UCT217	T217	UC217	84.0	61.9	11.0
	73	28	54	198	173	124	260	162	28	157	48	38	73	96	39.7	UCTX17	TX17	UCX17	96.1	71.5	11.7
	102	32	64	240	214	152	298	183	30	170	53	42	98	96	40	UCT317	T317	UC317	133	96.8	19.0
90	110	32	66	255	228	160	312	192	30	175	57	46	106	96	40	UCT318	T318	UC318	143	107	21.6
95	110	35	72	270	240	165	322	197	31	180	57	46	106	103	41	UCT319	T319	UC319	153	119	24.9
100	120	35	75	290	260	175	345	210	32	200	59	48	115	108	42	UCT320	T320	UC320	173	141	30.7
105	120	35	75	290	260	175	345	210	32	200	59	48	115	112	44	UCT321	T321	UC321	184	153	36.7
110	130	38	80	320	285	185	385	235	38	215	65	52	125	117	46	UCT322	T322	UC322	205	180	39.7
120	140	45	90	355	320	210	432	267	42	230	70	60	140	126	51	UCT324	T324	UC324	207	185	54.4
130	150	50	100	385	350	220	465	285	45	240	75	65	150	135	54	UCT326	T326	UC326	229	214	69.3
140	155	50	100	415	380	230	515	315	50	255	80	70	160	145	59	UCT328	T328	UC328	253	246	85.1

Remarks 1) Applicable sizes of grease nipples are shown below.

{	1/4-28UNF	201 – 210, X05 – X09, 305 – 308
	PT 1/8	211 – 217, X10 – X17, 309 – 328

2) For bearings with double- or triple-lip seals, unit and bearing number are suffixed by L2 or L3.

(For more detailed information, refer to ball bearing for unit specification tables.)

Ball bearing units
cartridge type
UCC (set screw locking)
 d 12 – 65 mm

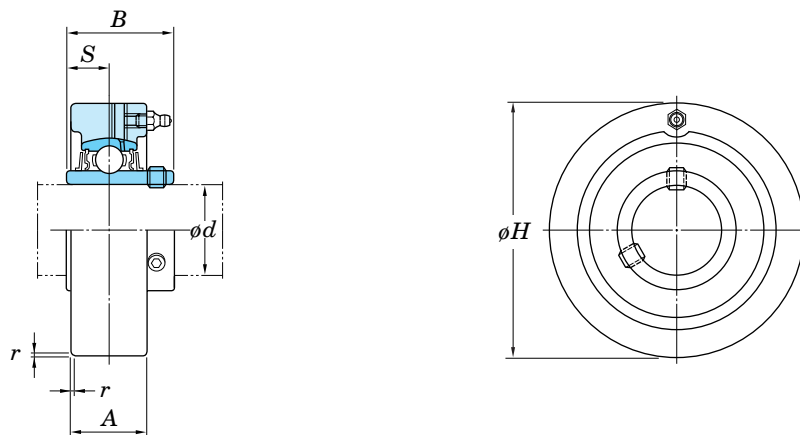

Shaft dia. (mm) d	Dimensions (mm)					Unit No.	Housing No.	Applicable bearing No.	Basic load ratings (kN)		(Refer.) Unit Mass (kg)
	H	A	r	B	S				C_r	C_{0r}	
12	72	20	1.5	31	12.7	UCC201	C204	UC201	12.8	6.65	0.52
15	72	20	1.5	31	12.7	UCC202	C204	UC202	12.8	6.65	0.50
17	72	20	1.5	31	12.7	UCC203	C204	UC203	12.8	6.65	0.49
20	72	20	1.5	31	12.7	UCC204	C204	UC204	12.8	6.65	0.47
25	80	22	1.5	34.1	14.3	UCC205	C205	UC205	14.0	7.85	0.64
30	85	27	1.5	38.1	15.9	UCC206	C206	UC206	19.5	11.3	0.81
35	90	28	2	42.9	17.5	UCC207	C207	UC207	25.7	15.4	0.93
40	100	30	2	49.2	19	UCC208	C208	UC208	29.1	17.8	1.2
45	110	31	2	49.2	19	UCC209	C209	UC209	32.7	20.3	1.5
50	120	33	2	51.6	19	UCC210	C210	UC210	35.1	23.3	2.0
55	125	35	2.5	55.6	22.2	UCC211	C211	UC211	43.4	29.4	2.2
60	130	38	2.5	65.1	25.4	UCC212	C212	UC212	52.4	36.2	2.6
65	140	40	2.5	65.1	25.4	UCC213	C213	UC213	57.2	40.1	3.0

Remarks 1) Applicable sizes of grease nipples are shown below.

(1/4-28UNF 201 – 213)

2) For bearings with double- or triple-lip seals, unit and bearing number are suffixed by L2 or L3.

(For more detailed information, refer to ball bearing for unit specification tables.)

Ball bearing units
light duty pillow block type
BLP (set screw locking)
***d* 12 – 40 mm**

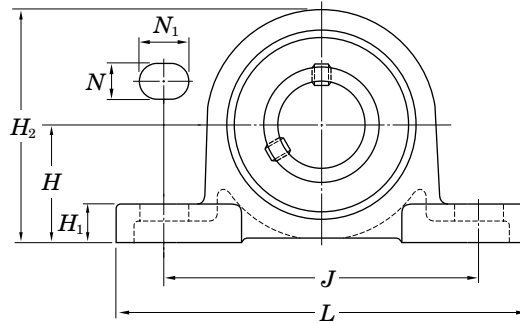
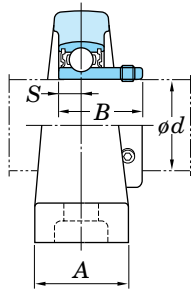

Shaft dia. (mm) <i>d</i>	Dimensions (mm)										Bolt size	Unit No.	Housing No.	Applicable bearing No.	Basic load ratings (kN)		(Refer.) Unit Mass (kg)
	<i>H</i>	<i>J</i>	<i>L</i>	<i>A</i>	<i>H</i> ₁	<i>H</i> ₂	<i>N</i>	<i>N</i> ₁	<i>B</i>	<i>S</i>					<i>C</i> _r	<i>C</i> _{0r}	
12	30.2	87	114	25	12	57	11	16	22	6	M10	BLP201	LP203	SB201	9.55	4.80	0.36
15	30.2	87	114	25	12	57	11	16	22	6	M10	BLP202	LP203	SB202	9.55	4.80	0.36
17	30.2	87	114	25	12	57	11	16	22	6	M10	BLP203	LP203	SB203	9.55	4.80	0.36
20	33.3	97	125	27	13	65	11	16	25	7	M10	BLP204	LP204	SB204	12.8	6.65	0.51
25	36.5	100	130	29	13	71	11	16	27	7.5	M10	BLP205	LP205	SB205	14.0	7.85	0.57
30	42.9	120	156	33	14	83	14	21	30	8	M12	BLP206	LP206	SB206	19.5	11.3	0.69
35	47.6	127	165	35	16	93	14	21	32	8.5	M12	BLP207	LP207	SB207	25.7	15.4	0.94
40	50.8	140	184	37	18	102	14	22	34	9	M12	BLP208	LP208	SB208	29.1	17.8	1.8

Ball bearing units
light duty rhombic-flanged type
BLF (set screw locking)
 d 12 – 35 mm

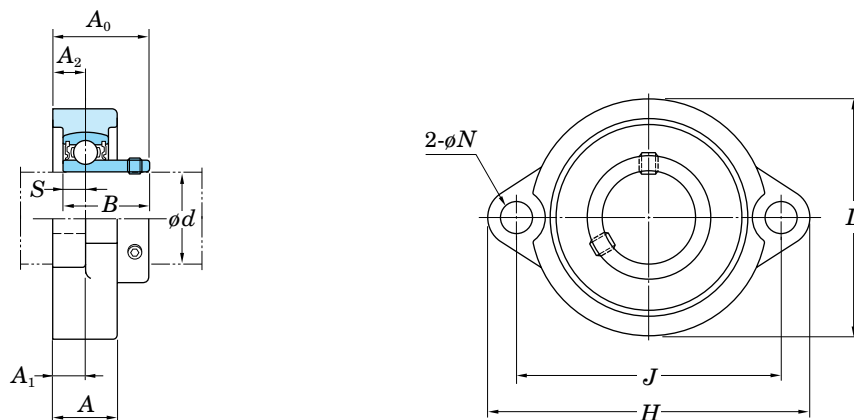

Shaft dia. (mm) d	Dimensions (mm)										Bolt size	Unit No.	Housing No.	Applicable bearing No.	Basic load ratings (kN)		(Refer.) Unit Mass (kg)
	H	J	L	A	A_1	A_2	A_0	N	B	S					C_r	C_{0r}	
12	81	63.5	52	18	9.5	9.5	25.5	8	22	6	M6	BLF201	LF203	SB201	9.55	4.80	0.25
15	81	63.5	52	18	9.5	9.5	25.5	8	22	6	M6	BLF202	LF203	SB202	9.55	4.80	0.25
17	81	63.5	52	18	9.5	9.5	25.5	8	22	6	M6	BLF203	LF203	SB203	9.55	4.80	0.25
20	90	71.5	60	20	11	11	29	10	25	7	M8	BLF204	LF204	SB204	12.8	6.65	0.33
25	95	76	64	20	11	11	30.5	10	27	7.5	M8	BLF205	LF205	SB205	14.0	7.85	0.38
30	113	90.5	76	22.5	12	12	34	12	30	8	M10	BLF206	LF206	SB206	19.5	11.3	0.57
35	122	100	89	24	13	13	36.5	12	32	8.5	M10	BLF207	LF207	SB207	25.7	15.4	0.77

Ball bearing units
"clean" series pillow block type
UP (set screw locking)
 d 10 – 30 mm

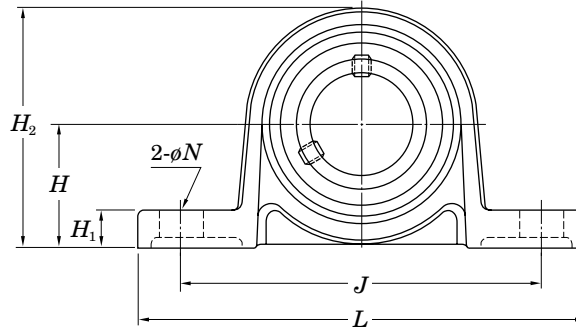
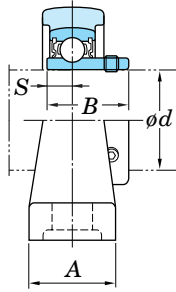

Shaft dia. (mm) d	Dimensions (mm)									Bolt size	Unit No.	Housing No.	Applicable bearing Basic load ratings (kN)		(Refer.) Unit Mass (kg)	
	H	J	L	A	H_1	H_2	N	B	S				No.	C_r		C_{0r}
10	18	53	67	16	6	35	7	15	5	M6	UP000	P000	SU000	4.55	1.95	0.070
12	19	56	71	16	6	38	7	15	5	M6	UP001	P001	SU001	5.10	2.40	0.090
15	22	63	80	16	7	43	7	16.5	5.5	M6	UP002	P002	SU002	5.60	2.85	0.110
17	24	67	85	18	7	47	7	17.5	6	M6	UP003	P003	SU003	6.00	3.25	0.150
20	28	80	100	20	9	55	10	21	7	M8	UP004	P004	SU004	9.40	5.05	0.230
25	32	90	112	20	10	62	10	22	7	M8	UP005	P005	SU005	10.1	5.85	0.280
30	36	106	132	26	11	70	13	24.5	7.5	M10	UP006	P006	SU006	13.2	8.25	0.420

Ball bearing units
"clean" series rhombic-flanged type
UFL (set screw locking)
 d 10 – 30 mm

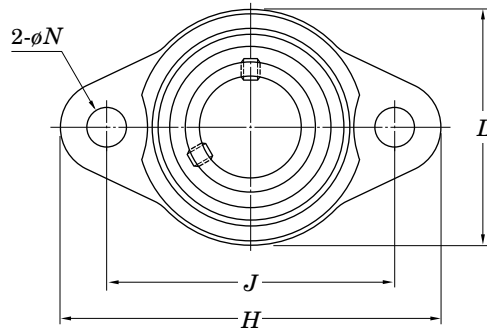
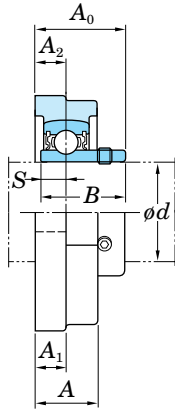

Shaft dia. (mm) d	Dimensions (mm)										Bolt size	Unit No.	Housing No.	Applicable bearing No.		Basic load ratings (kN)		(Refer.) Unit Mass (kg)
	H	J	L	A	A_1	A_2	A_0	N	B	S				C_r	C_{0r}			
10	60	45	36	12	6	6	16	7	15	5	M6	UFL000	FL000	SU000	4.55	1.95	0.050	
12	63	48	38	12	6	6	16	7	15	5	M6	UFL001	FL001	SU001	5.10	2.40	0.065	
15	67	53	42	13	6.5	6.5	17.5	7	16.5	5.5	M6	UFL002	FL002	SU002	5.60	2.85	0.085	
17	71	56	46	14	7	7	18.5	7	17.5	6	M6	UFL003	FL003	SU003	6.00	3.25	0.110	
20	90	71	55	16	8	8	22	10	21	7	M8	UFL004	FL004	SU004	9.40	5.05	0.180	
25	95	75	60	16	8	8	23	10	22	7	M8	UFL005	FL005	SU005	10.1	5.85	0.230	
30	112	85	70	18	9	9	26	13	24.5	7.5	M10	UFL006	FL006	SU006	13.2	8.25	0.310	

Ball bearing units
pressed steel pillow block type
SBPP (set screw locking)
d 12 – 35 mm

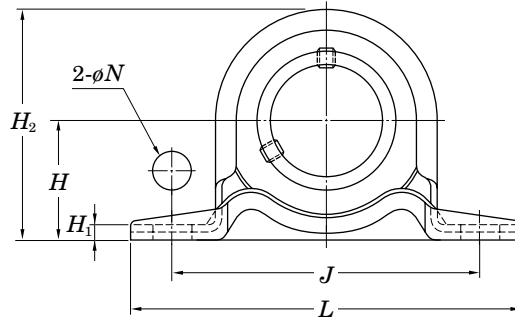
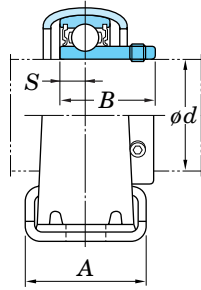

Shaft dia. (mm) <i>d</i>	Dimensions (mm)									Bolt size	Unit No.	Housing No.	Applicable bearing No.	Basic load ratings (kN)		(Refer.) Unit Mass (kg)
	<i>H</i>	<i>J</i>	<i>L</i>	<i>A</i>	<i>H</i> ₁	<i>H</i> ₂	<i>N</i>	<i>B</i>	<i>S</i>					<i>C</i> _r	<i>C</i> _{0r}	
12	22.2	68	86	25	3.2	43.8	9.5	22	6	M8	SBPP201F	PP203F	SB201	9.55	4.80	0.16
15	22.2	68	86	25	3.2	43.8	9.5	22	6	M8	SBPP202F	PP203F	SB202	9.55	4.80	0.16
17	22.2	68	86	25	3.2	43.8	9.5	22	6	M8	SBPP203F	PP203F	SB203	9.55	4.80	0.16
20	25.4	76	98	32	3.2	50.5	9.5	25	7	M8	SBPP204F	PP204F	SB204	12.8	6.65	0.23
25	28.6	86	108	32	4	56.6	11.5	27	7.5	M10	SBPP205F	PP205F	SB205	14.0	7.85	0.28
30	33.3	95	117	38	4	66.3	11.5	30	8	M10	SBPP206F	PP206F	SB206	19.5	11.3	0.47
35	39.7	106	129	41	4.6	78	11.5	32	8.5	M10	SBPP207F	PP207F	SB207	25.7	15.4	0.67

Ball bearing units
pressed steel rhombic-flanged type
SBPFL (set screw locking)
d 12 – 35 mm

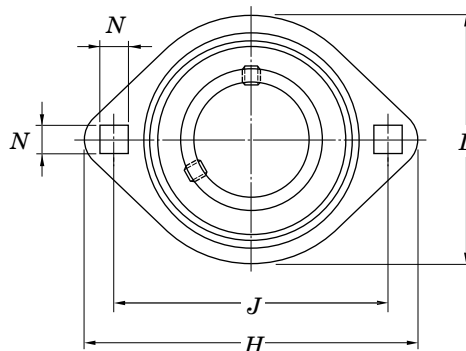
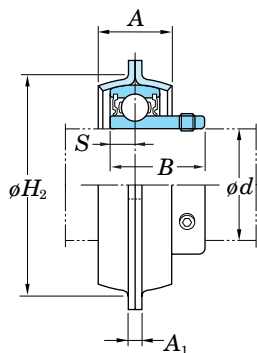

Shaft dia. (mm) <i>d</i>	Dimensions (mm)										Bolt size	Unit No.	Housing No.	Applicable bearing No.		Basic load ratings (kN)		(Refer.) Unit Mass (kg)
	<i>H</i>	<i>J</i>	<i>L</i>	<i>A</i>	<i>A</i> ₁	<i>N</i>	<i>H</i> ₂ ¹⁾	<i>B</i>	<i>S</i>	<i>C</i> _r				<i>C</i> _{0r}				
12	81	63.5	59	14	4	7.1	49	22	6	M6	SBPFL201	PFL203	SB201	9.55	4.80	0.19		
15	81	63.5	59	14	4	7.1	49	22	6	M6	SBPFL202	PFL203	SB202	9.55	4.80	0.19		
17	81	63.5	59	14	4	7.1	49	22	6	M6	SBPFL203	PFL203	SB203	9.55	4.80	0.19		
20	90	71.5	67	16	4	9	55	25	7	M8	SBPFL204	PFL204	SB204	12.8	6.65	0.24		
25	95	76	71	18	4	9	60	27	7.5	M8	SBPFL205	PFL205	SB205	14.0	7.85	0.28		
30	113	90.5	84	19	5.2	11	71	30	8	M10	SBPFL206	PFL206	SB206	19.5	11.3	0.38		
35	122	100	94	22	5.2	11	81	32	8.5	M10	SBPFL207	PFL207	SB207	25.7	15.4	0.66		

Note 1) H_2 shows minimum dimension of mounting hole.

Ball bearing units
pressed steel round-flanged type
SBPF (set screw locking)
***d* 12 – 35 mm**

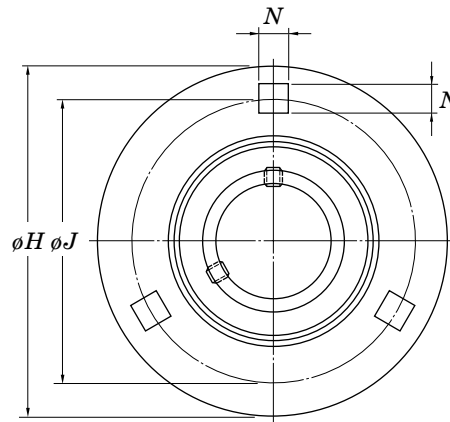
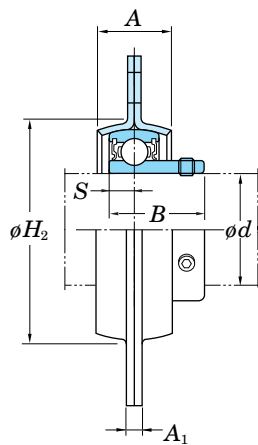

Shaft dia. (mm) <i>d</i>	Dimensions (mm)								Bolt size	Unit No.	Housing No.	Applicable bearing Basic load ratings (kN)		(Refer.) Unit Mass (kg)	
	<i>H</i>	<i>J</i>	<i>A</i>	<i>A</i> ₁	<i>N</i>	<i>H</i> ₂ ¹⁾	<i>B</i>	<i>S</i>				No.	<i>C</i> _r		<i>C</i> _{0r}
12	81	63.5	14	4	7.1	49	22	6	M6	SBPF201	PF203	SB201	9.55	4.80	0.27
15	81	63.5	14	4	7.1	49	22	6	M6	SBPF202	PF203	SB202	9.55	4.80	0.27
17	81	63.5	14	4	7.1	49	22	6	M6	SBPF203	PF203	SB203	9.55	4.80	0.27
20	90	71.5	16	4	9	55	25	7	M8	SBPF204	PF204	SB204	12.8	6.65	0.33
25	95	76	18	4	9	60	27	7.5	M8	SBPF205	PF205	SB205	14.0	7.85	0.38
30	113	90.5	19	5.2	11	71	30	8	M10	SBPF206	PF206	SB206	19.5	11.3	0.62
35	122	100	22	5.2	11	81	32	8.5	M10	SBPF207	PF207	SB207	25.7	15.4	0.82

Note 1) H_2 shows minimum dimension of mounting hole.

Ball bearings for units cylindrical bore type (set screw locking) d 10 – 40 mm

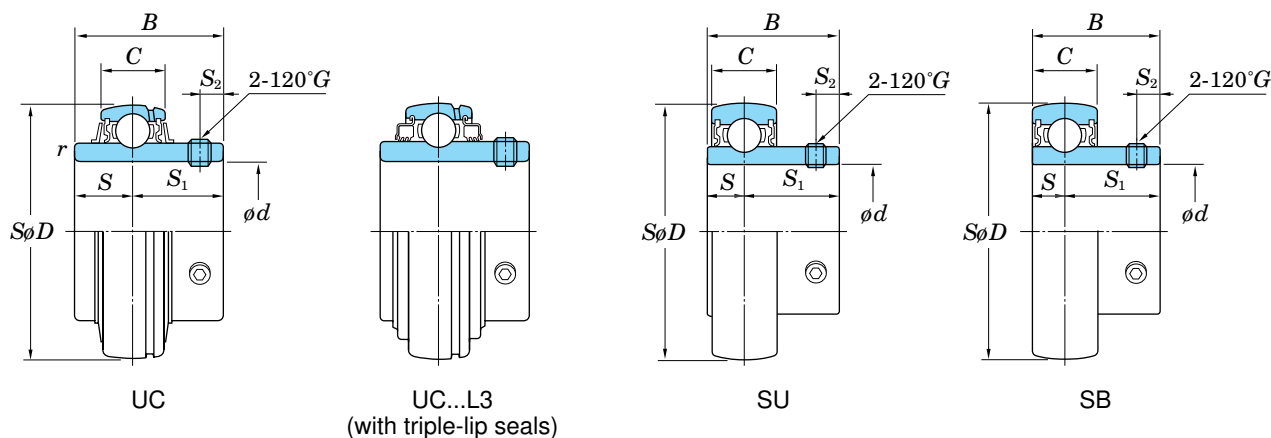

Shaft dia. (mm) d	Boundary dimensions (mm)				Basic load ratings (kN)		Bearing No.		Dimensions (mm)			Set screw size G	(Refer.) Mass (kg)
	D	B	C	r min.	C_r	C_{0r}	With standard seals	With triple-lip seals	S	S_1	S_2		
10	26	15	8	–	4.55	1.95	SU000	–	5	10	3	M3×0.35	0.024
12	28	15	8	–	5.10	2.40	SU001	–	5	10	3	M3×0.35	0.026
	40	22	12	–	9.55	4.80	SB201	–	6	16	4	M5×0.5	0.10
	47	31	16	0.6	12.8	6.65	UC201	UC201L2	12.7	18.3	5	M6×0.75	0.21
15	32	16.5	9	–	5.60	2.85	SU002	–	5.5	11	3.3	M4×0.5	0.038
	40	22	12	–	9.55	4.80	SB202	–	6	16	4	M5×0.5	0.10
	47	31	16	0.6	12.8	6.65	UC202	UC202L2	12.7	18.3	5	M6×0.75	0.19
17	35	17.5	10	–	6.00	3.25	SU003	–	6	11.5	3.3	M4×0.5	0.050
	40	22	12	–	9.55	4.80	SB203	–	6	16	4	M5×0.5	0.10
	47	31	16	0.6	12.8	6.65	UC203	UC203L2	12.7	18.3	5	M6×0.75	0.18
20	42	21	12	–	9.40	5.05	SU004	–	7	14	4	M5×0.5	0.080
	47	25	14	–	12.8	6.65	SB204	–	7	18	5	M6×0.75	0.15
	47	31	16	1	12.8	6.65	UC204	UC204L2	12.7	18.3	5	M6×0.75	0.16
25	47	22	12	–	10.1	5.85	SU005	–	7	15	4.5	M5×0.5	0.10
	52	27	15	–	14.0	7.85	SB205	–	7.5	19.5	5.5	M6×0.75	0.18
	52	34.1	17	1	14.0	7.85	UC205	UC205L2	14.3	19.8	5.5	M6×0.75	0.20
30	62	38	22	1.1	20.6	11.3	UC305	–	15	23	6	M6×0.75	0.45
	62	38.1	19	1	19.5	11.3	UCX05	UCX05L3	15.9	22.2	6	M6×0.75	0.39
	55	24.5	13	–	13.2	8.25	SU006	–	7.5	17	5.5	M5×0.5	0.15
35	62	30	16	–	19.5	11.3	SB206	–	8	22	6	M6×0.75	0.27
	62	38.1	19	1	19.5	11.3	UC206	UC206L3	15.9	22.2	6	M6×0.75	0.32
	72	42.9	20	1	25.7	15.4	UCX06	UCX06L3	17.5	25.4	6.5	M8×1	0.58
40	72	43	24	1.1	26.7	15.0	UC306	–	17	26	6	M6×0.75	0.56
	72	32	17	–	25.7	15.4	SB207	–	8.5	23.5	6	M6×0.75	0.42
	72	42.9	20	1.1	25.7	15.4	UC207	UC207L3	17.5	25.4	6.5	M8×1	0.48
40	80	48	26	1.5	33.4	19.3	UC307	UC307L3	19	29	8	M8×1	0.71
	80	49.2	21	1.1	29.1	17.8	UCX07	UCX07L3	19	30.2	8	M8×1	0.75
	80	34	18	–	29.1	17.8	SB208	–	9	25	8	M8×1	0.60
40	80	49.2	21	1.1	29.1	17.8	UC208	UC208L3	19	30.2	8	M8×1	0.64
	85	49.2	22	1.1	32.7	20.3	UCX08	UCX08L3	19	30.2	8	M8×1	0.83
	90	52	28	1.5	40.7	24.0	UC308	UC308L3	19	33	10	M10×1.25	1.00

Remark) Bearing in number range from UC201L2 to UC205L2 are double-lip sealed (L2) due to dimensional restriction.

d 45 – 140 mm

Shaft dia. (mm) <i>d</i>	Boundary dimensions (mm)				Basic load ratings (kN)		Bearing No.		Dimensions (mm)			Set screw size	(Refer.) Mass
	<i>D</i>	<i>B</i>	<i>C</i>	<i>r</i> min.	<i>C_r</i>	<i>C_{0r}</i>	With standard seals	With triple-lip seals	<i>S</i>	<i>S₁</i>	<i>S₂</i>	<i>G</i>	(kg)
45	85	49.2	22	1.1	32.7	20.3	UC209	UC209L3	19	30.2	8	M8×1	0.68
	90	51.6	24	1.1	35.1	23.3	UCX09	UCX09L3	19	32.6	9	M10×1.25	0.95
	100	57	30	1.5	48.9	29.5	UC309	UC309L3	22	35	10	M10×1.25	1.33
50	90	51.6	24	1.1	35.1	23.3	UC210	UC210L3	19	32.6	9	M10×1.25	0.80
	100	55.6	25	1.1	43.4	29.4	UCX10	UCX10L3	22.2	33.4	9	M10×1.25	1.29
	110	61	32	2	62.0	38.3	UC310	UC310L3	22	39	12	M12×1.5	1.69
55	100	55.6	25	1.5	43.4	29.4	UC211	UC211L3	22.2	33.4	9	M10×1.25	1.11
	110	65.1	27	1.5	52.4	36.2	UCX11	UCX11L3	25.4	39.7	10.5	M10×1.25	1.80
	120	66	34	2	71.6	45.0	UC311	UC311L3	25	41	12	M12×1.5	1.90
60	110	65.1	27	1.5	52.4	36.2	UC212	UC212L3	25.4	39.7	10.5	M10×1.25	1.54
	120	65.1	28	1.5	57.2	40.1	UCX12	UCX12L3	25.4	39.7	12	M12×1.5	2.05
	130	71	36	2.1	81.9	52.2	UC312	UC312L3	26	45	12	M12×1.5	2.60
65	120	65.1	28	1.5	57.2	40.1	UC213	UC213L3	25.4	39.7	12	M12×1.5	1.86
	125	74.6	30	1.5	62.2	44.1	UCX13	UCX13L3	30.2	44.4	12	M12×1.5	2.52
	140	75	38	2.1	92.7	59.9	UC313	UC313L3	30	45	12	M12×1.5	3.16
70	125	74.6	30	1.5	62.2	44.1	UC214	UC214L3	30.2	44.4	12	M12×1.5	2.05
	130	77.8	32	1.5	67.4	48.3	UCX14	UCX14L3	33.3	44.5	12	M12×1.5	2.74
	150	78	40	2.1	104	68.2	UC314	UC314L3	33	45	12	M12×1.5	3.90
75	130	77.8	32	1.5	67.4	48.3	UC215	UC215L3	33.3	44.5	12	M12×1.5	2.21
	140	82.6	33	1.5	72.7	53.0	UCX15	UCX15L3	33.3	49.3	14	M12×1.5	3.41
	160	82	42	2.1	113	77.2	UC315	UC315L3	32	50	14	M14×1.5	4.70
80	140	82.6	33	2	72.7	53.0	UC216	UC216L3	33.3	49.3	14	M12×1.5	2.79
	150	85.7	35	2	84.0	61.9	UCX16	UCX16L3	34.1	51.6	14	M12×1.5	3.87
	170	86	44	2.1	123	86.7	UC316	UC316L3	34	52	14	M14×1.5	5.60
85	150	85.7	35	2	84.0	61.9	UC217	UC217L3	34.1	51.6	14	M12×1.5	3.45
	160	96	38	2	96.1	71.5	UCX17	UCX17L3	39.7	56.3	15	M12×1.5	5.05
	180	96	46	3	133	96.8	UC317	UC317L3	40	56	16	M16×1.5	6.90
90	160	96	38	2	96.1	71.5	UC218	UC218L3	39.7	56.3	15	M12×1.5	4.35
	170	104	40	2	109	81.9	UCX18	–	42.9	61.1	16	M14×1.5	6.00
	190	96	48	3	143	107	UC318	UC318L3	40	56	16	M16×1.5	7.87
95	200	103	50	3	153	119	UC319	UC319L3	41	62	18	M16×1.5	8.91
100	190	117.5	43	2.1	133	105	UCX20	–	49.2	68.3	18	M16×1.5	8.56
	215	108	54	3	173	141	UC320	UC320L3	42	66	20	M18×1.5	11.2
105	225	112	56	3	184	153	UC321	–	44	68	20	M18×1.5	12.7
110	240	117	60	3	205	180	UC322	UC322L3	46	71	20	M18×1.5	15.1
120	260	126	64	3	207	185	UC324	UC324L3	51	75	20	M18×1.5	19.0
130	280	135	68	4	229	214	UC326	UC326L3	54	81	20	M20×1.5	23.6
140	300	145	72	4	253	246	UC328	UC328L3	59	86	20	M20×1.5	29.4

Ball bearings for units tapered bore type (adapter locking)

d_1 20 – 65 mm

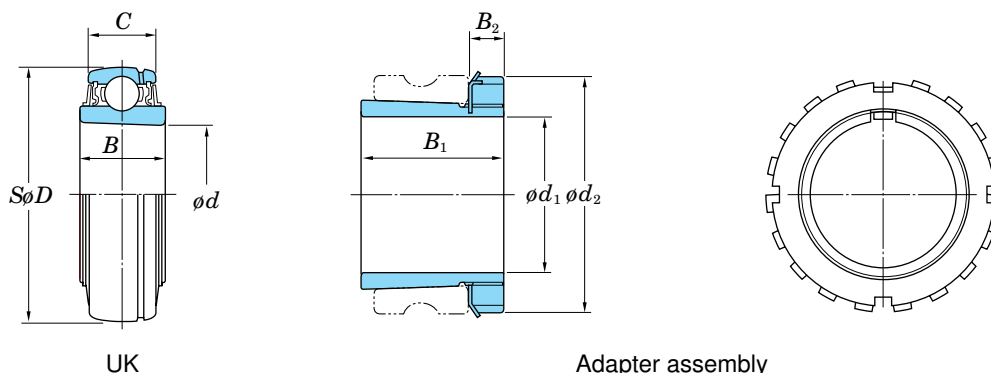

UK

Adapter assembly

Shaft dia. (mm) d_1	Boundary dimensions (mm)				Basic load ratings (kN)		Bearing No.	(Refer.) Mass (kg)	Applicable adapter assembly				Sleeve No.	
	d	D	B	C	C_r	C_{or}			No.	B_1	B_2	d_2		Mass (kg)
20	25	52	21	17	14.0	7.85	UK205	0.16	H305X	29	8	38	0.075	A305X
	25	62	23	19	19.5	11.3	UKX05	0.27	H2305X	35	8	38	0.095	A2305X
	25	62	27	22	20.6	11.3	UK305	0.40	H2305X	35	8	38	0.095	A2305X
25	30	62	23	19	19.5	11.3	UK206	0.25	H306X	31	8	45	0.11	A306X
	30	72	26	20	25.7	15.4	UKX06	0.43	H2306X	38	8	45	0.13	A2306X
	30	72	30	24	26.7	15.0	UK306	0.47	H2306X	38	8	45	0.13	A2306X
30	35	72	26	20	25.7	15.4	UK207	0.37	H307X	35	9	52	0.14	A307X
	35	80	27	21	29.1	17.8	UKX07	0.53	H2307X	43	9	52	0.17	A2307X
	35	80	33	26	33.4	19.3	UK307	0.60	H2307X	43	9	52	0.17	A2307X
35	40	80	27	21	29.1	17.8	UK208	0.47	H308X	36	10	58	0.19	A308X
	40	85	29	22	32.7	20.3	UKX08	0.58	H2308X	46	10	58	0.22	A2308X
	40	90	35	28	40.7	24.0	UK308	0.80	H2308X	46	10	58	0.22	A2308X
40	45	85	29	22	32.7	20.3	UK209	0.52	H309X	39	11	65	0.25	A309X
	45	90	29	24	35.1	23.3	UKX09	0.67	H2309X	50	11	65	0.28	A2309X
	45	100	38	30	48.9	29.5	UK309	1.08	H2309X	50	11	65	0.28	A2309X
45	50	90	29	24	35.1	23.3	UK210	0.59	H310X	42	12	70	0.30	A310X
	50	100	31	25	43.4	29.4	UKX10	0.89	H2310X	55	12	70	0.36	A2310X
	50	110	40	32	62.0	38.3	UK310	1.38	H2310X	55	12	70	0.36	A2310X
50	55	100	31	25	43.4	29.4	UK211	0.80	H311X	45	12	75	0.35	A311X
	55	110	33	27	52.4	36.2	UKX11	1.15	H2311X	59	12	75	0.42	A2311X
	55	120	43	34	71.6	45.0	UK311	1.78	H2311X	59	12	75	0.42	A2311X
55	60	110	33	27	52.4	36.2	UK212	1.02	H312X	47	13	80	0.43	A312X
	60	120	36	28	57.2	40.1	UKX12	1.45	H2312X	62	13	80	0.48	A2312X
	60	130	47	36	81.9	52.2	UK312	2.06	H2312X	62	13	80	0.48	A2312X
60	65	120	36	28	57.2	40.1	UK213	1.34	H313X	50	14	85	0.46	A313X
	65	125	40	30	62.2	44.1	UKX13	1.62	H2313X	65	14	85	0.56	A2313X
	65	140	49	38	92.7	59.9	UK313	2.71	H2313X	65	14	85	0.56	A2313X
65	75	130	40	32	67.4	48.3	UK215	1.50	H315X	55	15	98	0.83	A315X
	75	140	42	33	72.7	53.0	UKX15	2.10	H2315X	73	15	98	1.05	A2315X
	75	160	55	42	113	77.2	UK315	3.80	H2315X	73	15	98	1.05	A2315X

d_1 70 – 125 mm

Shaft dia. (mm) d_1	Boundary dimensions (mm)				Basic load ratings (kN)		Bearing No.	(Refer.) Mass (kg)	Applicable adapter assembly					
	d	D	B	C	C_r	C_{0r}			No.	B_1	B_2	d_2	Mass (kg)	Sleeve No.
70	80	140	42	33	72.7	53.0	UK216	1.96	H316X	59	17	105	1.05	A316X
	80	150	44	35	84.0	61.9	UKX16	2.64	H2316X	78	17	105	1.3	A2316X
	80	170	55	44	123	86.7	UK316	4.39	H2316X	78	17	105	1.3	A2316X
75	85	150	44	35	84.0	61.9	UK217	2.42	H317X	63	18	110	1.2	A317X
	85	160	48	38	96.1	71.5	UKX17	3.25	H2317X	82	18	110	1.45	A2317X
	85	180	60	46	133	96.8	UK317	5.30	H2317X	82	18	110	1.45	A2317X
80	90	160	48	38	96.1	71.5	UK218	2.90	H318X	65	18	120	1.4	A318X
	90	170	50	40	109	81.9	UKX18	3.80	H2318X	86	18	120	1.7	A2318X
	90	190	60	48	143	107	UK318	6.20	H2318X	86	18	120	1.7	A2318X
85	95	200	66	50	153	119	UK319	7.31	H2319X	90	19	125	1.95	A2319X
90	100	190	54	43	133	105	UKX20	5.36	H2320X	97	20	130	2.2	A2320X
	100	215	68	54	173	141	UK320	8.70	H2320X	97	20	130	2.2	A2320X
100	110	240	78	60	205	180	UK322	12.2	H2322X	105	21	145	2.75	A2322X
110	120	260	87	64	207	185	UK324	16.1	H2324	112	22	155	3.2	A2324
115	130	280	87	68	229	214	UK326	18.8	H2326	121	23	165	4.6	A2326
125	140	300	97	72	253	246	UK328	23.9	H2328	131	24	180	5.5	A2328

KOYO



Locknuts and lockwashers

Bearings are often fit to a shaft with an adapter sleeve, locknut, lockwasher or lock plate.

These accessories make it easy to attach and remove bearings.

They are standardized in JIS.

- Locknuts are standardized such that they can be used with either adapter sleeves, withdrawal sleeves or shafts.
- Lockwashers and lock plates are used as locks on locknuts.

Lockwashers are used with bearings of bore diameter number 40 or lower. Lock plates are used with those of bore diameter 44 or higher.

Locknuts

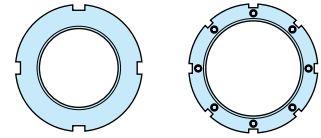

AN 02 - 100

Lockwashers

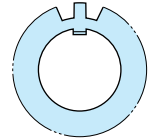

AW 00 - 40 (X)

Locknuts

for adapter sleeves and shafts

AN02 – 25

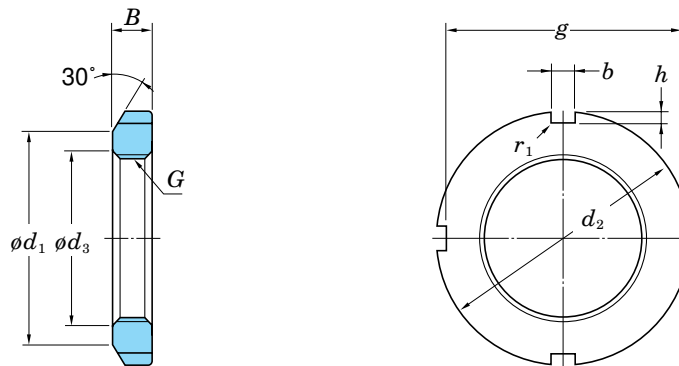

Locknut No.	Thread size $G^{1)}$	Standard dimensions (mm)								(Refer.) Mass (kg)	Applicable ²⁾ adapter sleeve (bore No.)	Applicable ³⁾ lockwasher No.
		d_2	d_1	g	d_3	b	h	B	$r_{\max.}$			
AN02 03 04	M 15×1	25	21	21	15.5	4	2	5	0.4	0.010	—	AW02
	M 17×1	28	24	24	17.5	4	2	5	0.4	0.013	—	03
	M 20×1	32	26	28	20.5	4	2	6	0.4	0.019	04	04
AN05 06 07	M 25×1.5	38	32	34	25.8	5	2	7	0.4	0.025	05	AW05
	M 30×1.5	45	38	41	30.8	5	2	7	0.4	0.043	06	06
	M 35×1.5	52	44	48	35.8	5	2	8	0.4	0.053	07	07
AN08 09 10	M 40×1.5	58	50	53	40.8	6	2.5	9	0.5	0.085	08	AW08
	M 45×1.5	65	56	60	45.8	6	2.5	10	0.5	0.119	09	09
	M 50×1.5	70	61	65	50.8	6	2.5	11	0.5	0.148	10	10
AN11 12 13	M 55×2	75	67	69	56	7	3	11	0.5	0.158	11	AW11
	M 60×2	80	73	74	61	7	3	11	0.5	0.174	12	12
	M 65×2	85	79	79	66	7	3	12	0.5	0.203	13	13
AN14 15 16	M 70×2	92	85	85	71	8	3.5	12	0.5	0.242	14	AW14
	M 75×2	98	90	91	76	8	3.5	13	0.5	0.287	15	15
	M 80×2	105	95	98	81	8	3.5	15	0.6	0.397	16	16
AN17 18 19	M 85×2	110	105	103	86	8	3.5	16	0.6	0.451	17	AW17
	M 90×2	120	108	112	91	10	4	16	0.6	0.556	18	18
	M 95×2	125	113	117	96	10	4	17	0.6	0.658	19	19
AN20 21 22	M100×2	130	120	122	101	10	4	18	0.6	0.698	20	AW20
	M105×2	140	126	130	106	12	5	18	0.7	0.845	21	21
	M110×2	145	133	135	111	12	5	19	0.7	0.965	22	22
AN23 24 25	M115×2	150	137	140	116	12	5	19	0.7	1.01	—	AW23
	M120×2	155	138	145	121	12	5	20	0.7	1.08	24	24
	M125×2	160	148	150	126	12	5	21	0.7	1.19	—	25

Notes 1) Basic profile and dimension of screw thread are in accordance with JIS B 0207 (metric fine screw threads).

2) Applicable to adapter sleeve series A31, A2, A3 and A23.

3) Applicable to lockwashers with flat inner tongue.

AN26 – 40

Locknut No.	Thread size $G^{1)}$	Standard dimensions (mm)								(Refer.) Mass (kg)	Applicable ²⁾ adapter sleeve (bore No.)	Applicable ³⁾ lockwasher No.
		d_2	d_1	g	d_3	b	h	B	$r_{max.}$			
AN26 27 28	M130×2	165	149	155	131	12	5	21	0.7	1.25	26	AW26
	M135×2	175	160	163	136	14	6	22	0.7	1.55	–	27
	M140×2	180	160	168	141	14	6	22	0.7	1.56	28	28
AN29 30 31	M145×2	190	172	178	146	14	6	24	0.7	1.80	–	AW29
	M150×2	195	171	183	151	14	6	24	0.7	2.03	30	30
	M155×3	200	182	186	156.5	16	7	25	0.7	2.30	–	–
AN32 33 34	M160×3	210	182	196	161.5	16	7	25	0.7	2.59	32	AW32
	M165×3	210	193	196	166.5	16	7	26	0.7	2.70	–	–
	M170×3	220	193	206	171.5	16	7	26	0.7	2.80	34	34
AN36 38 40	M180×3	230	203	214	181.5	18	8	27	0.7	3.07	36	AW36
	M190×3	240	214	224	191.5	18	8	28	0.7	3.39	38	38
	M200×3	250	226	234	201.5	18	8	29	0.7	3.69	40	40

Locknuts

for adapter sleeves and shafts

AN44 – 100

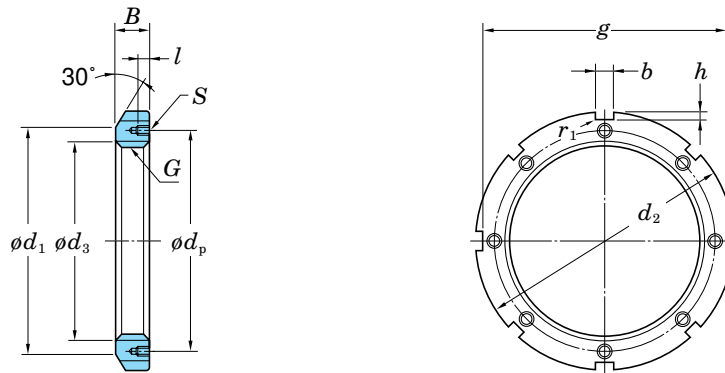

Locknut No.	Thread size $G^{1)}$	Standard dimensions (mm)								Tapped hole (mm)			(Refer.) Mass (kg)	Applicable ³⁾ adapter sleeve (bore No.)	Applicable lock plate No.
		d_2	d_1	g	d_3	b	h	B	$r_{max.}$	l	$S^{2)}$ Thread size	d_p			
AN44 48 52	Tr220×4	280	250	260	222	20	10	32	0.8	15	M 8×1.25	238	5.16	44	AL44
	Tr240×4	300	270	280	242	20	10	34	0.8	15	M 8×1.25	258	5.91	48	44
	Tr260×4	330	300	306	262	24	12	36	0.8	18	M10×1.5	281	7.99	52	52
AN56 60 64	Tr280×4	350	320	326	282	24	12	38	0.8	18	M10×1.5	301	8.99	56	AL52
	Tr300×4	380	340	356	302	24	12	40	0.8	18	M10×1.5	326	11.7	60	60
	Tr320×5	400	360	376	322.5	24	12	42	0.8	18	M10×1.5	345	13.0	64	64
AN68 72 76	Tr340×5	440	400	410	342.5	28	15	55	1	21	M12×1.75	372	23.0	68	AL68
	Tr360×5	460	420	430	362.5	28	15	58	1	21	M12×1.75	392	25.0	72	68
	Tr380×5	490	450	454	382.5	32	18	60	1	21	M12×1.75	414	30.8	76	76
AN80 84 88	Tr400×5	520	470	484	402.5	32	18	62	1	27	M16×2	439	36.7	80	AL80
	Tr420×5	540	490	504	422.5	32	18	70	1	27	M16×2	459	43.3	84	80
	Tr440×5	560	510	520	442.5	36	20	70	1	27	M16×2	477	45.1	88	88
AN92 96 100	Tr460×5	580	540	540	462.5	36	20	75	1	27	M16×2	497	50.2	92	AL88
	Tr480×5	620	560	580	482.5	36	20	75	1	27	M16×2	527	62.0	96	96
	Tr500×5	630	580	584	502.5	40	23	80	1	27	M16×2	539	63.1	/500	100

Notes 1) Basic profile and dimension of screw thread are in accordance with JIS B 0216.

2) Basic profile and dimension of bore with internal thread are in accordance with JIS B 0205 (metric coarse screw threads).

3) Applicable to adapter sleeve series A31, A32, A23 and A30.

Lockwashers

AW00 – 40(X)

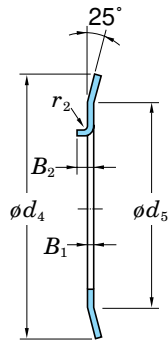

With bent inner tongue

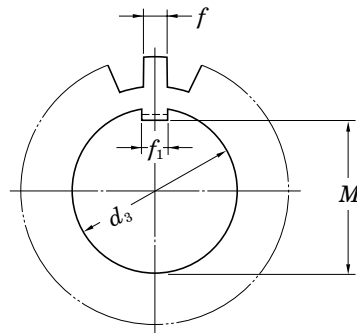

With flat inner tongue

Lockwasher No.		Standard dimensions (mm)										No. of tooth	(Refer.) Mass (kg/100pcs.)	Applicable adapter sleeve (bore No.)	Applicable locknut No.
With bent inner tongue	With flat inner tongue	d_3	M	f_1	B_1	f	d_4	d_5	r	B_2					
AW00	AW00X	10	8.5	3	1	3	13	21	0.5	2	9	0.131	—	AN00	
01	01X	12	10.5	3	1	3	17	25	0.5	2	9	0.192	—	01	
02	02X	15	13.5	4	1	4	21	28	1	2.5	13	0.253	—	02	
AW03	AW03X	17	15.5	4	1	4	24	32	1	2.5	13	0.313	—	AN03	
04	04X	20	18.5	4	1	4	26	36	1	2.5	13	0.350	04	04	
05	05X	25	23	5	1.2	5	32	42	1	2.5	13	0.640	05	05	
AW06	AW06X	30	27.5	5	1.2	5	38	49	1	2.5	13	0.780	06	AN06	
07	07X	35	32.5	6	1.2	5	44	57	1	2.5	15	1.04	07	07	
08	08X	40	37.5	6	1.2	6	50	62	1	2.5	15	1.23	08	08	
AW09	AW09X	45	42.5	6	1.2	6	56	69	1	2.5	17	1.52	09	AN09	
10	10X	50	47.5	6	1.2	6	61	74	1	2.5	17	1.60	10	10	
11	11X	55	52.5	8	1.2	7	67	81	1	4	17	1.96	11	11	
AW12	AW12X	60	57.5	8	1.5	7	73	86	1.2	4	17	2.53	12	AN12	
13	13X	65	62.5	8	1.5	7	79	92	1.2	4	19	2.90	13	13	
14	14X	70	66.5	8	1.5	8	85	98	1.2	4	19	3.34	14	14	
AW15	AW15X	75	71.5	8	1.5	8	90	104	1.2	4	19	3.56	15	AN15	
16	16X	80	76.5	10	1.8	8	95	112	1.2	4	19	4.64	16	16	
17	17X	85	81.5	10	1.8	8	102	119	1.2	4	19	5.24	17	17	
AW18	AW18X	90	86.5	10	1.8	10	108	126	1.2	4	19	6.23	18	AN18	
19	19X	95	91.5	10	1.8	10	113	133	1.2	4	19	6.70	19	19	
20	20X	100	96.5	12	1.8	10	120	142	1.2	6	19	7.65	20	20	
AW21	AW21X	105	100.5	12	1.8	12	126	145	1.2	6	19	8.26	21	AN21	
22	22X	110	105.5	12	1.8	12	133	154	1.2	6	19	9.40	22	22	
23	23X	115	110.5	12	2	12	137	159	1.5	6	19	10.8	—	23	
AW24	AW24X	120	115	14	2	12	138	164	1.5	6	19	10.5	24	AN24	
25	25X	125	120	14	2	12	148	170	1.5	6	19	11.8	—	25	
26	26X	130	125	14	2	12	149	175	1.5	6	19	11.3	26	26	
AW27	AW27X	135	130	14	2	14	160	185	1.5	6	19	14.4	—	AN27	
28	28X	140	135	16	2	14	160	192	1.5	8	19	14.2	28	28	
29	29X	145	140	16	2	14	172	202	1.5	8	19	16.8	—	29	
AW30	AW30X	150	145	16	2	14	171	205	1.5	8	19	15.5	30	AN30	
31	31X	155	147.5	16	2.5	16	182	212	1.5	8	19	20.9	—	31	
32	32X	160	154	18	2.5	16	182	217	1.5	8	19	22.2	32	32	
AW33	AW33X	165	157.5	18	2.5	16	193	222	1.5	8	19	24.1	—	AN33	
34	34X	170	164	18	2.5	16	193	232	1.5	8	19	24.7	34	34	
36	36X	180	174	20	2.5	18	203	242	1.5	8	19	26.8	36	36	
AW38	AW38X	190	184	20	2.5	18	214	252	1.5	8	19	27.8	38	AN38	
40	40X	200	194	20	2.5	18	226	262	1.5	8	19	29.3	40	40	

Remarks 1) AW00–AW40, AW00X–AW40X are applicable to adapter assembly series H31, H2, H3 and H23.

2) For adapter sleeves with narrow slits, lockwashers with flat inner tongue should be used. Either type of lockwasher can be used for adapter sleeves with wide slits.

Supplementary tables

Contents

1. Shaft tolerances (deviation from nominal dimensions)	C 2
2. Housing bore tolerances (deviation from nominal dimensions)	C 4
3. Numerical values for standard tolerance grades IT	C 6
4. Greek alphabet list	C 7
5. Prefixes used with SI units	C 7
6. SI units and conversion factors	C 8
7. Inch/millimeter conversion	C12
8. Steel hardness conversion	C13
9. Surface roughness comparison	C14
10. Viscosity conversion	C15

Supplementary table 1 Shaft tolerances (deviation from nominal dimensions)

Nominal shaft diameter (mm)		Deviation classes of shaft diameter															
over	up to	d6	e6	f6	g5	g6	h5	h6	h7	h8	h9	h10	js5	js6	js7	j5	j6
3	6	-30 -38	-20 -28	-10 -18	-4 -9	-4 -12	0 -5	0 -8	0 -12	0 -18	0 -30	0 -48	± 2.5	± 4	± 6	+3 -2	+6 -2
6	10	-40 -49	-25 -34	-13 -22	-5 -11	-5 -14	0 -6	0 -9	0 -15	0 -22	0 -36	0 -58	± 3	± 4.5	± 7	+4 -2	+7 -2
10	18	-50 -61	-32 -43	-16 -27	-6 -14	-6 -17	0 -8	0 -11	0 -18	0 -27	0 -43	0 -70	± 4	± 5.5	± 9	+5 -3	+8 -3
18	30	-65 -78	-40 -53	-20 -33	-7 -16	-7 -20	0 -9	0 -13	0 -21	0 -33	0 -52	0 -84	± 4.5	± 6.5	± 10	+5 -4	+9 -4
30	50	-80 -96	-50 -66	-25 -41	-9 -20	-9 -25	0 -11	0 -16	0 -25	0 -39	0 -62	0 -100	± 5.5	± 8	± 12	+6 -5	+11 -5
50	80	-100 -119	-60 -79	-30 -49	-10 -23	-10 -29	0 -13	0 -19	0 -30	0 -46	0 -74	0 -120	± 6.5	± 9.5	± 15	+6 -7	+12 -7
80	120	-120 -142	-72 -94	-36 -58	-12 -27	-12 -34	0 -15	0 -22	0 -35	0 -54	0 -87	0 -140	± 7.5	± 11	± 17	+6 -9	+13 -9
120	180	-145 -170	-85 -110	-43 -68	-14 -32	-14 -39	0 -18	0 -25	0 -40	0 -63	0 -100	0 -160	± 9	± 12.5	± 20	+7 -11	+14 -11
180	250	-170 -199	-100 -129	-50 -79	-15 -35	-15 -44	0 -20	0 -29	0 -46	0 -72	0 -115	0 -185	± 10	± 14.5	± 23	+7 -13	+16 -13
250	315	-190 -222	-110 -142	-56 -88	-17 -40	-17 -49	0 -23	0 -32	0 -52	0 -81	0 -130	0 -210	± 11.5	± 16	± 26	+7 -16	± 16
315	400	-210 -246	-125 -161	-62 -98	-18 -43	-18 -54	0 -25	0 -36	0 -57	0 -89	0 -140	0 -230	± 12.5	± 18	± 28	+7 -18	± 18
400	500	-230 -270	-135 -175	-68 -108	-20 -47	-20 -60	0 -27	0 -40	0 -63	0 -97	0 -155	0 -250	± 13.5	± 20	± 31	+7 -20	± 20
500	630	-260 -304	-145 -189	-76 -120	-	-22 -66	-	0 -44	0 -70	0 -110	0 -175	0 -280	-	± 22	± 35	-	-
630	800	-290 -340	-160 -210	-80 -130	-	-24 -74	-	0 -50	0 -80	0 -125	0 -200	0 -320	-	± 25	± 40	-	-
800	1 000	-320 -376	-170 -226	-86 -142	-	-26 -82	-	0 -56	0 -90	0 -140	0 -230	0 -360	-	± 28	± 45	-	-

Note 1) Δ_{dmp} : single plane mean bore diameter deviation

Unit μm (Refer.)

											Nominal shaft diameter (mm)		$\Delta d_{mp}^{(1)}$ of bearing (class 0)	
											over	up to		
	k5	k6	k7	m5	m6	m7	n5	n6	p6	r6	r7			
	+6 +1	+9 +1	+13 +1	+9 +4	+12 +4	+16 +4	+13 +8	+16 +8	+20 +12	+23 +15	+27 +15	3	6	0 - 8
	+7 +1	+10 +1	+16 +1	+12 +6	+15 +6	+21 +6	+16 +10	+19 +10	+24 +15	+28 +19	+34 +19	6	10	0 - 8
	+9 +1	+12 +1	+19 +1	+15 +7	+18 +7	+25 +7	+20 +12	+23 +12	+29 +18	+34 +23	+41 +23	10	18	0 - 8
	+11 +2	+15 +2	+23 +2	+17 +8	+21 +8	+29 +8	+24 +15	+28 +15	+35 +22	+41 +28	+49 +28	18	30	0 - 10
	+13 +2	+18 +2	+27 +2	+20 +9	+25 +9	+34 +9	+28 +17	+33 +17	+42 +26	+50 +34	+59 +34	30	50	0 - 12
	+15 +2	+21 +2	+32 +2	+24 +11	+30 +11	+41 +11	+33 +20	+39 +20	+51 +32	+60 +41	+71 +41	50	65	0 - 15
										+62 +43	+73 +43	65	80	
	+18 +3	+25 +3	+38 +3	+28 +13	+35 +13	+48 +13	+38 +23	+45 +23	+59 +37	+73 +51	+86 +51	80	100	0 - 20
										+76 +54	+89 +54	100	120	
	+21 +3	+28 +3	+43 +3	+33 +15	+40 +15	+55 +15	+45 +27	+52 +27	+68 +43	+88 +63	+103 +63	120	140	
										+90 +65	+105 +65	140	160	0 - 25
										+93 +68	+108 + 68	160	180	
	+24 +4	+33 +4	+50 +4	+37 +17	+46 +17	+63 +17	+51 +31	+60 +31	+79 +50	+106 +77	+123 +77	180	200	
										+109 +80	+126 +80	200	225	0 - 30
										+113 +84	+130 +84	225	250	
	+27 +4	+36 +4	+56 +4	+43 +20	+52 +20	+72 +20	+57 +34	+66 +34	+88 +56	+126 +94	+146 +94	250	280	0 - 35
										+130 +98	+150 +98	280	315	
	+29 +4	+40 +4	+61 +4	+46 +21	+57 +21	+78 +21	+62 +37	+73 +37	+98 +62	+144 +108	+165 +108	315	355	0 - 40
										+150 +114	+171 +114	355	400	
	+32 +5	+45 +5	+68 +5	+50 +23	+63 +23	+86 +23	+67 +40	+80 +40	+108 +68	+166 +126	+189 +126	400	450	0 - 45
										+172 +132	+195 +132	450	500	
	-	+44 0	+70 0	-	+70 +26	+96 +26	-	+88 +44	+122 +78	+194 +150	+220 +150	500	560	0 - 50
										+199 +155	+225 +155	560	630	
	-	+50 0	+80 0	-	+80 +30	+110 +30	-	+100 +50	+138 +88	+225 +175	+255 +175	630	710	0 - 75
										+235 +185	+265 +185	710	800	
	-	+56 0	+90 0	-	+90 +34	+124 +34	-	+112 +56	+156 +100	+266 +210	+300 +210	800	900	0 - 100
										+276 +220	+310 +220	900	1 000	

Supplementary table 2 Housing bore tolerances (deviation from nominal dimensions)

Nominal bore diameter (mm)		Deviation classes of housing bore diameter														
over	up to	E6	F6	F7	G6	G7	H6	H7	H8	H9	H10	J6	J7	JS5	JS6	JS7
10	18	+43	+27	+34	+17	+24	+11	+18	+27	+43	+70	+6	+10	± 4	± 5.5	± 9
		+32	+16	+16	+6	+6	0	0	0	0	0	0	-5			
18	30	+53	+33	+41	+20	+28	+13	+21	+33	+52	+84	+8	+12	± 4.5	± 6.5	± 10
		+40	+20	+20	+7	+7	0	0	0	0	0	0	-5			
30	50	+66	+41	+50	+25	+34	+16	+25	+39	+62	+100	+10	+14	± 5.5	± 8	± 12
		+50	+25	+25	+9	+9	0	0	0	0	0	0	-6			
50	80	+79	+49	+60	+29	+40	+19	+30	+46	+74	+120	+13	+18	± 6.5	± 9.5	± 15
		+60	+30	+30	+10	+10	0	0	0	0	0	0	-6			
80	120	+94	+58	+71	+34	+47	+22	+35	+54	+87	+140	+16	+22	± 7.5	± 11	± 17
		+72	+36	+36	+12	+12	0	0	0	0	0	0	-6			
120	180	+110	+68	+83	+39	+54	+25	+40	+63	+100	+160	+18	+26	± 9	± 12.5	± 20
		+85	+43	+43	+14	+14	0	0	0	0	0	0	-7			
180	250	+129	+79	+96	+44	+61	+29	+46	+72	+115	+185	+22	+30	± 10	± 14.5	± 23
		+100	+50	+50	+15	+15	0	0	0	0	0	0	-7			
250	315	+142	+88	+108	+49	+69	+32	+52	+81	+130	+210	+25	+36	± 11.5	± 16	± 26
		+110	+56	+56	+17	+17	0	0	0	0	0	0	-7			
315	400	+161	+98	+119	+54	+75	+36	+57	+89	+140	+230	+29	+39	± 12.5	± 18	± 28
		+125	+62	+62	+18	+18	0	0	0	0	0	0	-7			
400	500	+175	+108	+131	+60	+83	+40	+63	+97	+155	+250	+33	+43	± 13.5	± 20	± 31
		+135	+68	+68	+20	+20	0	0	0	0	0	0	-7			
500	630	+189	+120	+146	+66	+92	+44	+70	+110	+175	+280	-	-	-	± 22	± 35
		+145	+76	+76	+22	+22	0	0	0	0	0	0	0			
630	800	+210	+130	+160	+74	+104	+50	+80	+125	+200	+320	-	-	-	± 25	± 40
		+160	+80	+80	+24	+24	0	0	0	0	0	0	0			
800	1 000	+226	+142	+176	+82	+116	+56	+90	+140	+230	+360	-	-	-	± 28	± 45
		+170	+86	+86	+26	+26	0	0	0	0	0	0	0			
1 000	1 250	+261	+164	+203	+94	+133	+66	+105	+165	+260	+420	-	-	-	± 33	± 52
		+195	+98	+98	+28	+28	0	0	0	0	0	0	0			

Note 1) ΔD_{mp} : single plane mean outside diameter deviation

Unit μm (Refer.)

													Nominal bore diameter (mm)		$\Delta D_{mp}^{1)}$ of bearing (class 0)
	K5	K6	K7	M5	M6	M7	N5	N6	N7	P6	P7	R7	over	up to	
	+2	+2	+6	-4	-4	0	-9	-9	-5	-15	-11	-16	10	18	0
	-6	-9	-12	-12	-15	-18	-17	-20	-23	-26	-29	-34			-8
	+1	+2	+6	-5	-4	0	-12	-11	-7	-18	-14	-20	18	30	0
	-8	-11	-15	-14	-17	-21	-21	-24	-28	-31	-35	-41			-9
	+2	+3	+7	-5	-4	0	-13	-12	-8	-21	-17	-25	30	50	0
	-9	-13	-18	-16	-20	-25	-24	-28	-33	-37	-42	-50			-11
	+3	+4	+9	-6	-5	0	-15	-14	-9	-26	-21	-30	50	65	0
	-10	-15	-21	-19	-24	-30	-28	-33	-39	-45	-51	-60	65	80	-13
	+2	+4	+10	-8	-6	0	-18	-16	-10	-30	-24	-38	80	100	0
	-13	-18	-25	-23	-28	-35	-33	-38	-45	-52	-59	-73	100	120	-15
	+3	+4	+12	-9	-8	0	-21	-20	-12	-36	-28	-48	120	140	(up to 150)
	-15	-21	-28	-27	-33	-40	-39	-45	-52	-61	-68	-88	140	160	0
												-50	160	180	-18
												-90			(over 150)
												-53			0
												-93			-25
	+2	+5	+13	-11	-8	0	-25	-22	-14	-41	-33	-60	180	200	0
	-18	-24	-33	-31	-37	-46	-45	-51	-60	-70	-79	-106	200	225	-30
												-63	225	250	
												-109			
												-67			
												-113			
	+3	+5	+16	-13	-9	0	-27	-25	-14	-47	-36	-74	250	280	0
	-20	-27	-36	-36	-41	-52	-50	-57	-66	-79	-88	-126	280	315	-35
												-78			
												-130			
	+3	+7	+17	-14	-10	0	-30	-26	-16	-51	-41	-87	315	355	0
	-22	-29	-40	-39	-46	-57	-55	-62	-73	-87	-98	-144	355	400	-40
												-93			
												-150			
	+2	+8	+18	-16	-10	0	-33	-27	-17	-55	-45	-103	400	450	0
	-25	-32	-45	-43	-50	-63	-60	-67	-80	-95	-108	-166	450	500	-45
												-109			
												-172			
	-	0	0	-	-26	-26	-	-44	-44	-78	-78	-150	500	560	0
		-44	-70		-70	-96		-88	-114	-122	-148	-220	560	630	-50
												-155			
												-225			
	-	0	0	-	-30	-30	-	-50	-50	-88	-88	-175	630	710	0
		-50	-80		-80	-110		-100	-130	-138	-168	-255	710	800	-75
												-185			
												-265			
	-	0	0	-	-34	-34	-	-56	-56	-100	-100	-210	800	900	0
		-56	-90		-90	-124		-112	-146	-156	-190	-300	900	1 000	-100
												-220			
												-310			
	-	0	0	-	-40	-40	-	-66	-66	-120	-120	-250	1 000	1 120	0
		-66	-105		-106	-145		-132	-171	-186	-225	-355	1 120	1 250	-125
												-260			
												-365			

Supplementary table 3 Numerical values for standard tolerance grades IT

Basic size (mm)		Standard tolerance grades (IT)																	
		1	2	3	4	5	6	7	8	9	10	11	12	13	14 ¹⁾	15 ¹⁾	16 ¹⁾	17 ¹⁾	18 ¹⁾
over	up to	Tolerances (µm)											Tolerances (mm)						
-	3	0.8	1.2	2	3	4	6	10	14	25	40	60	0.10	0.14	0.26	0.40	0.60	1.00	1.40
3	6	1	1.5	2.5	4	5	8	12	18	30	48	75	0.12	0.18	0.30	0.48	0.75	1.20	1.80
6	10	1	1.5	2.5	4	6	9	15	22	36	58	90	0.15	0.22	0.36	0.58	0.90	1.50	2.20
10	18	1.2	2	3	5	8	11	18	27	43	70	110	0.18	0.27	0.43	0.70	1.10	1.80	2.70
18	30	1.5	2.5	4	6	9	13	21	33	52	84	130	0.21	0.33	0.52	0.84	1.30	2.10	3.30
30	50	1.5	2.5	4	7	11	16	25	39	62	100	160	0.25	0.39	0.62	1.00	1.60	2.50	3.90
50	80	2	3	5	8	13	19	30	46	74	120	190	0.30	0.46	0.74	1.20	1.90	3.00	4.60
80	120	2.5	4	6	10	15	22	35	54	87	140	220	0.35	0.54	0.87	1.40	2.20	3.50	5.40
120	180	3.5	5	8	12	18	25	40	63	100	160	250	0.40	0.63	1.00	1.60	2.50	4.00	6.30
180	250	4.5	7	10	14	20	29	46	72	115	185	290	0.46	0.72	1.15	1.85	2.90	4.60	7.20
250	315	6	8	12	16	23	32	52	81	130	210	320	0.52	0.81	1.30	2.10	3.20	5.20	8.10
315	400	7	9	13	18	25	36	57	89	140	230	360	0.57	0.89	1.40	2.30	3.60	5.70	8.90
400	500	8	10	15	20	27	40	63	97	155	250	400	0.63	0.97	1.55	2.50	4.00	6.30	9.70
500	630	-	-	-	-	-	44	70	110	175	280	440	0.70	1.10	1.75	2.80	4.40	7.00	11.00
630	800	-	-	-	-	-	50	80	125	200	320	500	0.80	1.25	2.00	3.20	5.00	8.00	12.50
800	1 000	-	-	-	-	-	56	90	140	230	360	560	0.90	1.40	2.30	3.60	5.60	9.00	14.00
1 000	1 250	-	-	-	-	-	66	105	165	260	420	660	1.05	1.65	2.60	4.20	6.60	10.50	16.50
1 250	1 600	-	-	-	-	-	78	125	195	310	500	780	1.25	1.95	3.10	5.00	7.80	12.50	19.50
1 600	2 000	-	-	-	-	-	92	150	230	370	600	920	1.50	2.30	3.70	6.00	9.20	15.00	23.00
2 000	2 500	-	-	-	-	-	110	175	280	440	700	1 100	1.75	2.80	4.40	7.00	11.00	17.50	28.00
2 500	3 150	-	-	-	-	-	135	210	330	540	860	1 350	2.10	3.30	5.40	8.60	13.50	21.00	33.00

Note 1) Standard tolerance grades IT 14 to IT 18 (incl.) shall not be used for basic sizes less than or equal to 1 mm.

Supplementary table 4 Greek alphabet list

Name	Roman type	Italic type		Name	Roman type	Italic type	
	Capital	Capital	Lowercase		Capital	Capital	Lowercase
alpha	A	<i>A</i>	α	nu	N	<i>N</i>	ν
beta	B	<i>B</i>	β	xi	Ξ	<i>Ξ</i>	ξ
gamma	Γ	<i>Γ</i>	γ	omicron	O	<i>O</i>	o
delta	Δ	<i>Δ</i>	δ	pi	Π	<i>Π</i>	π
epsilon	E	<i>E</i>	ϵ, ϵ	rho	P	<i>P</i>	ρ
zeta	Z	<i>Z</i>	ζ	sigma	Σ	<i>Σ</i>	σ
eta	H	<i>H</i>	η	tau	T	<i>T</i>	τ
theta	Θ	<i>Θ</i>	θ, θ	upsilon	Υ	<i>Υ</i>	υ
iota	I	<i>I</i>	ι	phi	Φ	<i>Φ</i>	ϕ, ϕ
kappa	K	<i>K</i>	κ, κ	chi	X	<i>X</i>	χ
lambda	Λ	<i>Λ</i>	λ	psi	Ψ	<i>Ψ</i>	ψ
mu	M	<i>M</i>	μ	omega	Ω	<i>Ω</i>	ω

Supplementary table 5 Prefixes used with SI units

Factor	Prefix		Factor	Prefix	
	Name	Symbol		Name	Symbol
10^{18}	exa	E	10^{-1}	deci	d
10^{15}	peta	P	10^{-2}	centi	c
10^{12}	tera	T	10^{-3}	milli	m
10^9	giga	G	10^{-6}	micro	
10^6	mega	M	10^{-9}	nano	n
10^3	kilo	k	10^{-12}	pico	p
10^2	hecto	h	10^{-15}	femto	f
10	deka	da	10^{-18}	atto	a

Supplementary table 6 (1) SI units and conversion factors

Mass	SI units	Other Units ¹⁾	Conversion into SI units	Conversion from SI units
Angle	rad [radian(s)]	° [degree(s)] * ' [minute(s)] * " [second(s)] *	1° = π / 180 rad 1' = π / 10 800 rad 1" = π / 648 000 rad	1 rad = 57.295 78°
Length	m [meter(s)]	Å [Angstrom unit] ** μ [micron(s)] in [inch(es)] ft [foot(feet)] yd [yard(s)] mile [mile(s)]	1Å = 10 ⁻¹⁰ m = 0.1 nm = 100 pm 1μ = 1μm 1 in = 25.4 mm 1 ft = 12 in = 0.304 8 m 1 yd = 3 ft = 0.914 4 m 1 mile = 5 280 ft = 1 609.344 m	1 m = 10 ¹⁰ Å 1 m = 39.37 in 1 m = 3.280 8 ft 1 m = 1.093 6 yd 1 km = 0.621 4 mile
Area	m ²	a [are(s)] ** ha [hectare(s)] ** acre [acre(s)]	1 a = 100 m ² 1 ha = 10 ⁴ m ² 1 acre = 4 840 yd ² = 4 046.86 m ²	1 km ² = 247.1 acre
Volume	m ³	ℓ, L [liter(s)] * cc [cubic centimeters] gal (US) [gallon(s)] floz (US) [fluid ounce(s)] barrel (US) [barrels(US)]	1 ℓ = 1 dm ³ = 10 ⁻³ m ³ 1 cc = 1 cm ³ = 10 ⁻⁶ m ³ 1 gal (US) = 231 in ³ = 3.785 41 dm ³ 1 floz (US) = 29.573 5 cm ³ 1 barrel (US) = 158.987 dm ³	1 m ³ = 10 ³ ℓ 1 m ³ = 10 ⁶ cc 1 m ³ = 264.17 gal 1 m ³ = 33 814 floz 1 m ³ = 6.289 8 barrel
Time	s [second(s)]	min [minute(s)] * h [hour(s)] * d [day(s)] *		
Angular velocity	rad/s			
Velocity	m/s	kn [knot(s)] ** m/h *	1 kn = 1 852 m/h	1 km/h = 0.539 96 kn
Acceleration	m/s ²	G	1 G = 9.806 65 m/s ²	1 m/s ² = 0.101 97 G
Frequency	Hz [hertz]	c/s [cycle(s)/second]	1 c/s = 1 s ⁻¹ = 1 Hz	
Rotational frequency	s ⁻¹	rpm [revolutions per minute] min ⁻¹ * r/min **	1 rpm = 1/60 s ⁻¹	1 s ⁻¹ = 60 rpm
Mass	kg [kilogram(s)]	t [ton(s)] * lb [pound(s)] gr [grain(s)] oz [ounce(s)] ton (UK) [ton(s) (UK)] ton (US) [ton(s) (US)] car [carat(s)]	1 t = 10 ³ kg 1 lb = 0.453 592 37 kg 1 gr = 64.798 91 mg 1 oz = 1/16 lb = 28.349 5 g 1 ton (UK) = 1 016.05 kg 1 ton (US) = 907.185 kg 1 car = 200 mg	1 kg = 2.204 6 lb 1 g = 15.432 4 gr 1 kg = 35.274 0 oz 1 t = 0.984 2 ton (UK) 1 t = 1.102 3 ton (US) 1 g = 5 car

Note 1) * : Unit can be used as an SI unit.
** : Unit can be used as an SI unit for the time being.
No asterisk : Unit cannot be used.

Supplementary table 6 (2) SI units and conversion factors

Mass	SI units	Other Units ¹⁾	Conversion into SI units	Conversion from SI units
Density	kg/m ³			
Linear density	kg/m			
Momentum	kg · m/s			
Moment of momentum Angular momentum	} kg · m ² /s			
Moment of inertia		kg · m ²		
Force	N [newton(s)]	dyn [dyne(s)] kgf [kilogram-force] gf [gram-force] tf [ton-force] lbf [pound-force]	1 dyn = 10 ⁻⁵ N 1 kgf = 9.806 65 N 1 gf = 9.806 65 × 10 ⁻³ N 1 tf = 9.806 65 × 10 ³ N 1 lbf = 4.448 22 N	1 N = 10 ⁵ dyn 1 N = 0.101 97 kgf 1 N = 0.224 809 lbf
Moment of force	N · m [newton meter(s)]	gf · cm kgf · cm kgf · m tf · m tf · lbf	1 gf · cm = 9.806 65 × 10 ⁻⁵ N · m 1 kgf · cm = 9.806 65 × 10 ⁻² N · m 1 kgf · m = 9.806 65 N · m 1 tf · m = 9.806 65 × 10 ³ N · m 1 ft · lbf = 1.355 82 N · m	1 N · m = 0.101 97 kgf · m 1 N · m = 0.737 56 ft · lbf
Pressure Normal stress	Pa [pascal(s)] {1 Pa = 1 N/m ² }	gf/cm ² kgf/mm ² kgf/m ² lbf/in ² bar [bar(s)] at [engineering air pressure] mH ₂ O, mAq [meter water column] atm [atmosphere] mHg [meter mercury column] Torr [torr]	1 gf/cm ² = 9.806 65 × 10 Pa 1 kgf/mm ² = 9.806 65 × 10 ⁶ Pa 1 kgf/m ² = 9.806 65 Pa 1 lbf/in ² = 6 894.76 Pa 1 bar = 10 ⁵ Pa 1 at = 1kgf/cm ² = 9.806 65 × 10 ⁴ Pa 1 mH ₂ O = 9.806 65 × 10 ³ Pa 1 atm = 101 325 Pa 1 mHg = $\frac{101\,325}{0.76}$ Pa 1 Torr = 1mmHg = 133.322 Pa	1 MPa = 0.101 97 kgf/mm ² 1 Pa = 0.101 97 kgf/m ² 1 Pa = 0.145 × 10 ⁻³ lbf/in ² 1 Pa = 10 ⁻² mbar 1 Pa = 7.500 6 × 10 ⁻³ Torr
Viscosity	Pa · s [pascal second]	P [poise] kgf · s/m ²	10 ⁻² P = 1 cP = 1 mPa · s 1 kgf · s/m ² = 9.806 65 Pa · s	1 Pa · s = 0.101 97 kgf · s/m ²
Kinematic viscosity	m ² /s	St [stokes]	10 ⁻² St = 1 cSt = 1 mm ² /s	
Surface tension	N/m			

Note 1)

* : Unit can be used as an SI unit.

** : Unit can be used as an SI unit for the time being.

No asterisk : Unit cannot be used.

Supplementary table 6 (3) SI units and conversion factors

Mass	SI units	Other Units ¹⁾	Conversion into SI units	Conversion from SI units
Work	J [joule(s)]	eV [electron volt(s)] erg [erg(s)]	1 eV = (1.602 189 2±0.000 004 6)×10 ⁻¹⁹ J 1 erg = 10 ⁻⁷ J	1 J = 10 ⁷ erg
Energy	W · s [watt(s) second] { 1 J = 1 N · m 1 W · s = 1 J }	kgf · m ft · lbf	1 kgf · m = 9.806 65 J 1 ft · lbf = 1.355 82 J	1 J = 0.101 97 kgf · m 1 J = 0.737 56 ft · lbf
Power	W [watt(s)] { 1 W = 1 J/s }	erg/s [ergs per second] kgf · m/s PS [French horse-power] HP [horse-power (British)] ft · lbf/s	1 erg/s = 10 ⁻⁷ W 1 kgf · m/s = 9.806 65 W 1 PS = 75 kgf · m/s = 735.5 W 1 HP = 550 ft · lbf/s = 745.7 W 1 ft · lbf/s = 1.355 82 W	1 W = 0.101 97 kgf · m/s 1 W = 0.001 36 PS 1 W = 0.001 34 HP
Thermo-dynamic temperature	K ⁻¹ [kelvin(s)] { t K = (t - 273.15) °C }			
Celsius temperature	°C [celsius(s)] { t °C = (t + 273.15) K }	°F [degree(s) Fahrenheit]	t °F = $\frac{5}{9}(t - 32)$ °C	t °C = $(\frac{9}{5}t + 32)$ °F
Linear expansion coefficient	K ⁻¹	°C ⁻¹ [per degree]		
Heat	J [joule(s)]	erg [erg(s)] kgf · m cal [calories] cal ₁₅ [15 degree calories] cal _{IT} [I. T. calories]	1 erg = 10 ⁻⁷ J 1 cal = 4.186 05 J (when temperature is not specified) 1 cal ₁₅ = 4.185 5 J 1 cal _{IT} = 4.186 J 1 Mcal _{IT} = 1.163 kW · h	1 J = 10 ⁷ erg 1 J = 0.238 89 cal 1 kW · h = 0.86 × 10 ⁶ cal
Thermal conductivity	W/ (m · K)	W/ (m · °C) cal/ (s · m · °C)	1 W/ (m · °C) = 1 W/ (m · K) 1 cal/ (s · m · °C) = 4.186 05 W/ (m · K)	
Coefficient of heat transfer	W/ (m ² · K)	W/ (m ² · °C) cal/ (s · m ² · °C)	1 W/ (m ² · °C) = 1 W/ (m ² · K) 1 cal/ (s · m ² · °C) = 4.186 05 W/ (m ² · K)	
Heat capacity	J/K	J/°C	1 J/°C = 1 J/K	
Massic heat capacity	J/ (kg · K)	J/ (kg · °C)		

Note 1) * : Unit can be used as an SI unit.
 ** : Unit can be used as an SI unit for the time being.
 No asterisk : Unit cannot be used.

Supplementary table 6 (4) SI units and conversion factors

Mass	SI units	Other Units ¹⁾	Conversion into SI units	Conversion from SI units
Electric current	A [ampere(s)]			
Electric charge Quantity of electricity	C [coulomb(s)] {1 C = 1 A · s}	A · h *	1 A · h = 3.6 kC	
Tension Electric potential	V [volt(s)] {1 V = 1 W/A}			
Capacitance	F [farad(s)] {1 F = 1 C/V}			
Magnetic field strength	A/m	Oe [oersted(s)]	$1 \text{ Oe} = \frac{10^3}{4\pi} \text{ A/m}$	$1 \text{ A/m} = 4\pi \times 10^{-3} \text{ Oe}$
Magnetic flux density	T [tesla(s)] $\left\{ \begin{array}{l} 1 \text{ T} = 1 \text{ N}/(\text{A} \cdot \text{m}) \\ = 1 \text{ Wb}/\text{m}^2 \\ = 1 \text{ V} \cdot \text{s}/\text{m}^2 \end{array} \right\}$	Gs [gauss(es)] γ [gamma(s)]	$1 \text{ Gs} = 10^{-4} \text{ T}$ $1 \gamma = 10^{-9} \text{ T}$	$1 \text{ T} = 10^4 \text{ Gs}$ $1 \text{ T} = 10^9 \gamma$
Magnetic flux	Wb [weber(s)] {1 Wb = 1 V · s}	Mx [maxwell(s)]	$1 \text{ Mx} = 10^{-8} \text{ Wb}$	$1 \text{ Wb} = 10^8 \text{ Mx}$
Self inductance	H [henry (–ries)] {1 H = 1 Wb/A}			
Resistance (to direct current)	Ω [ohm(s)] {1 Ω = 1 V/A}			
Conductance (to direct current)	S [siemens] {1 S = 1 A/V}			
Active power	W $\left\{ \begin{array}{l} 1 \text{ W} = 1 \text{ J/s} \\ = 1 \text{ A} \cdot \text{V} \end{array} \right\}$			

Note 1) * : Unit can be used as an SI unit.
 ** : Unit can be used as an SI unit for the time being.
 No asterisk : Unit cannot be used.

Supplementary table 7 Inch/millimeter conversion

Inch	Inches											
	0	1	2	3	4	5	6	7	8	9	10	
	mm											
0	0	0	25.4000	50.8000	76.2000	101.6000	127.0000	152.4000	177.8000	203.2000	228.6000	254.0000
1/64	0.015625	0.3969	25.7969	51.1969	76.5969	101.9969	127.3969	152.7969	178.1969	203.5969	228.9969	254.3969
1/32	0.03125	0.7938	26.1938	51.5938	76.9938	102.3938	127.7938	153.1938	178.5938	203.9938	229.3938	254.7938
3/64	0.046875	1.1906	26.5906	51.9906	77.3906	102.7906	128.1906	153.5906	178.9906	204.3906	229.7906	255.1906
1/16	0.0625	1.5875	26.9875	52.3875	77.7875	103.1875	128.5875	153.9875	179.3875	204.7875	230.1875	255.5875
5/64	0.078125	1.9844	27.3844	52.7844	78.1844	103.5844	128.9844	154.3844	179.7844	205.1844	230.5844	255.9844
3/32	0.09375	2.3812	27.7812	53.1812	78.5812	103.9812	129.3812	154.7812	180.1812	205.5812	230.9812	256.3812
7/64	0.109375	2.7781	28.1781	53.5781	78.9781	104.3781	129.7781	155.1781	180.5781	205.9781	231.3781	256.7781
1/8	0.125	3.1750	28.5750	53.9750	79.3750	104.7750	130.1750	155.5750	180.9750	206.3750	231.7750	257.1750
9/64	0.140625	3.5719	28.9719	54.3719	79.7719	105.1719	130.5719	155.9719	181.3719	206.7719	232.1719	257.5719
5/32	0.15625	3.9688	29.3688	54.7688	80.1688	105.5688	130.9688	156.3688	181.7688	207.1688	232.5688	257.9688
11/64	0.171875	4.3656	29.7656	55.1656	80.5656	105.9656	131.3656	156.7656	182.1656	207.5656	232.9656	258.3656
3/16	0.1875	4.7625	30.1625	55.5625	80.9625	106.3625	131.7625	157.1625	182.5625	207.9625	233.3625	258.7625
13/64	0.203125	5.1594	30.5594	55.9594	81.3594	106.7594	132.1594	157.5594	182.9594	208.3594	233.7594	259.1594
7/32	0.21875	5.5562	30.9562	56.3562	81.7562	107.1562	132.5562	157.9562	183.3562	208.7562	234.1562	259.5562
15/64	0.234375	5.9531	31.3531	56.7531	82.1531	107.5531	132.9531	158.3531	183.7531	209.1531	234.5531	259.9531
1/4	0.25	6.3500	31.7500	57.1500	82.5500	107.9500	133.3500	158.7500	184.1500	209.5500	234.9500	260.3500
17/64	0.265625	6.7469	32.1469	57.5469	82.9469	108.3469	133.7469	159.1469	184.5469	209.9469	235.3469	260.7469
9/32	0.28125	7.1438	32.5438	57.9438	83.3438	108.7438	134.1438	159.5438	184.9438	210.3438	235.7438	261.1438
19/64	0.296875	7.5406	32.9406	58.3406	83.7406	109.1406	134.5406	159.9406	185.3406	210.7406	236.1406	261.5406
5/16	0.3125	7.9375	33.3375	58.7375	84.1375	109.5375	134.9375	160.3375	185.7375	211.1375	236.5375	261.9375
21/64	0.328125	8.3344	33.7344	59.1344	84.5344	109.9344	135.3344	160.7344	186.1344	211.5344	236.9344	262.3344
11/32	0.34375	8.7312	34.1312	59.5312	84.9312	110.3312	135.7312	161.1312	186.5312	211.9312	237.3312	262.7312
23/64	0.359375	9.1281	34.5281	59.9281	85.3281	110.7281	136.1281	161.5281	186.9281	212.3281	237.7281	263.1281
3/8	0.375	9.5250	34.9250	60.3250	85.7250	111.1250	136.5250	161.9250	187.3250	212.7250	238.1250	263.5250
25/64	0.390625	9.9219	35.3219	60.7219	86.1219	111.5219	136.9219	162.3219	187.7219	213.1219	238.5219	263.9219
13/32	0.40625	10.3188	35.7188	61.1188	86.5188	111.9188	137.3188	162.7188	188.1188	213.5188	238.9188	264.3188
27/64	0.421875	10.7156	36.1156	61.5156	86.9156	112.3156	137.7156	163.1156	188.5156	213.9156	239.3156	264.7156
7/16	0.4375	11.1125	36.5125	61.9125	87.3125	112.7125	138.1125	163.5125	188.9125	214.3125	239.7125	265.1125
29/64	0.453125	11.5094	36.9094	62.3094	87.7094	113.1094	138.5094	163.9094	189.3094	214.7094	240.1094	265.5094
15/32	0.46875	11.9062	37.3062	62.7062	88.1062	113.5062	138.9062	164.3062	189.7062	215.1062	240.5062	265.9062
31/64	0.484375	12.3031	37.7031	63.1031	88.5031	113.9031	139.3031	164.7031	190.1031	215.5031	240.9031	266.3031
1/2	0.5	12.7000	38.1000	63.5000	88.9000	114.3000	139.7000	165.1000	190.5000	215.9000	241.3000	266.7000
33/64	0.515625	13.0969	38.4969	63.8969	89.2969	114.6969	140.0969	165.4969	190.8969	216.2969	241.6969	267.0969
17/32	0.53125	13.4938	38.8938	64.2938	89.6938	115.0938	140.4938	165.8938	191.2938	216.6938	242.0938	267.4938
35/64	0.546875	13.8906	39.2906	64.6906	90.0906	115.4906	140.8906	166.2906	191.6906	217.0906	242.4906	267.8906
9/16	0.5625	14.2875	39.6875	65.0875	90.4875	115.8875	141.2875	166.6875	192.0875	217.4875	242.8875	268.2875
37/64	0.578125	14.6844	40.0844	65.4844	90.8844	116.2844	141.6844	167.0844	192.4844	217.8844	243.2844	268.6844
19/32	0.59375	15.0812	40.4812	65.8812	91.2812	116.6812	142.0812	167.4812	192.8812	218.2812	243.6812	269.0812
39/64	0.609375	15.4781	40.8781	66.2781	91.6781	117.0781	142.4781	167.8781	193.2781	218.6781	244.0781	269.4781
5/8	0.625	15.8750	41.2750	66.6750	92.0750	117.4750	142.8750	168.2750	193.6750	219.0750	244.4750	269.8750
41/64	0.640625	16.2719	41.6719	67.0719	92.4719	117.8719	143.2719	168.6719	194.0719	219.4719	244.8719	270.2719
21/32	0.65625	16.6688	42.0688	67.4688	92.8688	118.2688	143.6688	169.0688	194.4688	219.8688	245.2688	270.6688
43/64	0.671875	17.0656	42.4656	67.8656	93.2656	118.6656	144.0656	169.4656	194.8656	220.2656	245.6656	271.0656
11/16	0.6875	17.4625	42.8625	68.2625	93.6625	119.0625	144.4625	169.8625	195.2625	220.6625	246.0625	271.4625
45/64	0.703125	17.8594	43.2594	68.6594	94.0594	119.4594	144.8594	170.2594	195.6594	221.0594	246.4594	271.8594
23/32	0.71875	18.2562	43.6562	69.0562	94.4562	119.8562	145.2562	170.6562	196.0562	221.4562	246.8562	272.2562
47/64	0.734375	18.6531	44.0531	69.4531	94.8531	120.2531	145.6531	171.0531	196.4531	221.8531	247.2531	272.6531
3/4	0.75	19.0500	44.4500	69.8500	95.2500	120.6500	146.0500	171.4500	196.8500	222.2500	247.6500	273.0500
49/64	0.765625	19.4469	44.8469	70.2469	95.6469	121.0469	146.4469	171.8469	197.2469	222.6469	248.0469	273.4469
25/32	0.78125	19.8438	45.2438	70.6438	96.0438	121.4438	146.8438	172.2438	197.6438	223.0438	248.4438	273.8438
51/64	0.796875	20.2406	45.6406	71.0406	96.4406	121.8406	147.2406	172.6406	198.0406	223.4406	248.8406	274.2406
13/16	0.8125	20.6375	46.0375	71.4375	96.8375	122.2375	147.6375	173.0375	198.4375	223.8375	249.2375	274.6375
53/64	0.828125	21.0344	46.4344	71.8344	97.2344	122.6344	148.0344	173.4344	198.8344	224.2344	249.6344	275.0344
27/32	0.84375	21.4312	46.8312	72.2312	97.6312	123.0312	148.4312	173.8312	199.2312	224.6312	250.0312	275.4312
55/64	0.859375	21.8281	47.2281	72.6281	98.0281	123.4281	148.8281	174.2281	199.6281	225.0281	250.4281	275.8281
7/8	0.875	22.2250	47.6250	73.0250	98.4250	123.8250	149.2250	174.6250	200.0250	225.4250	250.8250	276.2250
57/64	0.890625	22.6219	48.0219	73.4219	98.8219	124.2219	149.6219	175.0219	200.4219	225.8219	251.2219	276.6219
29/32	0.90625	23.0188	48.4188	73.8188	99.2188	124.6188	150.0188	175.4188	200.8188	226.2188	251.6188	277.0188
59/64	0.921875	23.4156	48.8156	74.2156	99.6156	125.0156	150.4156	175.8156	201.2156	226.6156	252.0156	277.4156
15/16	0.9375	23.8125	49.2125	74.6125	100.0125	125.4125	150.8125	176.2125	201.6125	227.0125	252.4125	277.8125
61/64	0.953125	24.2094	49.6094	75.0094	100.4094	125.8094	151.2094	176.6094	202.0094	227.4094	252.8094	278.2094
31/32	0.96875	24.6062	50.0062	75.4062	100.8062	126.2062	151.6062	177.0062	202.406			

Supplementary table 8 Steel hardness conversion

Rockwell	Vicker's	Brinell		Rockwell		Shore
C-scale 1471.0 N {150 kgf}		Standard ball	Tungsten carbide ball	A-scale 588.4 N {60 kgf}	B-scale 980.7 N {100 kgf}	
68	940			85.6		97
67	900			85.0		95
66	865			84.5		92
65	832		739	83.9		91
64	800		722	83.4		88
63	772		705	82.8		87
62	746		688	82.3		85
61	720		670	81.8		83
60	697		654	81.2		81
59	674		634	80.7		80
58	653		615	80.1		78
57	633		595	79.6		76
56	613		577	79.0		75
55	595	—	560	78.5		74
54	577	—	543	78.0		72
53	560	—	525	77.4		71
52	544	500	512	76.8		69
51	528	487	496	76.3		68
50	513	475	481	75.9		67
49	498	464	469	75.2		66
48	484	451	455	74.7		64
47	471	442	443	74.1		63
46	458	432	432	73.6		62
45	446		421	73.1		60
44	434		409	72.5		58
43	423		400	72.0		57
42	412		390	71.5		56
41	402		381	70.9		55
40	392		371	70.4	—	54
39	382		362	69.9	—	52
38	372		353	69.4	—	51
37	363		344	68.9	—	50
36	354		336	68.4	(109.0)	49
35	345		327	67.9	(108.5)	48
34	336		319	67.4	(108.0)	47
33	327		311	66.8	(107.5)	46
32	318		301	66.3	(107.0)	44
31	310		294	65.8	(106.0)	43
30	302		286	65.3	(105.5)	42
29	294		279	64.7	(104.5)	41
28	286		271	64.3	(104.0)	41
27	279		264	63.8	(103.0)	40
26	272		258	63.3	(102.5)	38
25	266		253	62.8	(101.5)	38
24	260		247	62.4	(101.0)	37
23	254		243	62.0	100.0	36
22	248		237	61.5	99.0	35
21	243		231	61.0	98.5	35
20	238		226	60.5	97.8	34
(18)	230		219	—	96.7	33
(16)	222		212	—	95.5	32
(14)	213		203	—	93.9	31
(12)	204		194	—	92.3	29
(10)	196		187		90.7	28
(8)	188		179		89.5	27
(6)	180		171		87.1	26
(4)	173		165		85.5	25
(2)	166		158		83.5	24
(0)	160		152		81.7	24

Supplementary table 9 Surface roughness comparison

Arithmetical mean deviation of the profile R_a	Maximum height of the profile R_{max}	Ten-point height of irregularities R_z	Roughness grade numbers N	Symbol
0.013 a	0.05 S	0.05 Z		
0.025 a	0.1 S	0.1 Z	N 1	
0.05 a	0.2 S	0.2 Z	N 2	▽▽▽▽
0.10 a	0.4 S	0.4 Z	N 3	
0.20 a	0.8 S	0.8 Z	N 4	
0.40 a	1.6 S	1.6 Z	N 5	
0.80 a	3.2 S	3.2 Z	N 6	▽▽▽
1.6 a	6.3 S	6.3 Z	N 7	
3.2 a	12.5 S	12.5 Z	N 8	▽▽
6.3 a	25 S	25 Z	N 9	
12.5 a	50 S	50 Z	N10	▽
25 a	100 S	100 Z	N11	
50 a	200 S	200 Z	N12	
100 a	400 S	400 Z		

Notes) Above table is applicable only when processed surface peaks are of equal height.
 Above table is roughly applicable to processed surfaces for general use.
 Numbers are combined only for convenience in deciding surface roughness.

Supplementary table 10 Viscosity conversion

Kinematic viscosity mm ² /s	Saybolt SUS (second)		Redwood R (second)		Engler E (degree)	Kinematic viscosity mm ² /s	Saybolt SUS (second)		Redwood R (second)		Engler E (degree)
	100 °F	210 °F	50 °C	100 °C			100 °F	210 °F	50 °C	100 °C	
2	32.6	32.8	30.8	31.2	1.14	35	163	164	144	147	4.70
3	36.0	36.3	33.3	33.7	1.22	36	168	170	148	151	4.83
4	39.1	39.4	35.9	36.5	1.31	37	172	173	153	155	4.96
5	42.3	42.6	38.5	39.1	1.40	38	177	178	156	159	5.08
6	45.5	45.8	41.1	41.7	1.48	39	181	183	160	164	5.21
7	48.7	49.0	43.7	44.3	1.56	40	186	187	164	168	5.34
8	52.0	52.4	46.3	47.0	1.65	41	190	192	168	172	5.47
9	55.4	55.8	49.1	50.0	1.75	42	195	196	172	176	5.59
10	58.8	59.2	52.1	52.9	1.84	43	199	201	176	180	5.72
11	62.3	62.7	55.1	56.0	1.93	44	204	205	180	185	5.85
12	65.9	66.4	58.2	59.1	2.02	45	208	210	184	189	5.98
13	69.6	70.1	61.4	62.3	2.12	46	213	215	188	193	6.11
14	73.4	73.9	64.7	65.6	2.22	47	218	219	193	197	6.24
15	77.2	77.7	68.0	69.1	2.32	48	222	224	197	202	6.37
16	81.1	81.7	71.5	72.6	2.43	49	227	228	201	206	6.50
17	85.1	85.7	75.0	76.1	2.54	50	231	233	205	210	6.63
18	89.2	89.8	78.6	79.7	2.64	55	254	256	225	231	7.24
19	93.3	94.0	82.1	83.6	2.76	60	277	279	245	252	7.90
20	97.5	98.2	85.8	87.4	2.87	65	300	302	266	273	8.55
21	102	102	89.5	91.3	2.98	70	323	326	286	294	9.21
22	106	107	93.3	95.1	3.10	75	346	349	306	315	9.89
23	110	111	97.1	98.9	3.22	80	371	373	326	336	10.5
24	115	115	101	103	3.34	85	394	397	347	357	11.2
25	119	120	105	107	3.46	90	417	420	367	378	11.8
26	123	124	109	111	3.58	95	440	443	387	399	12.5
27	128	129	112	115	3.70	100	464	467	408	420	13.2
28	132	133	116	119	3.82	120	556	560	490	504	15.8
29	137	138	120	123	3.95	140	649	653	571	588	18.4
30	141	142	124	127	4.07	160	742	747	653	672	21.1
31	145	146	128	131	4.20	180	834	840	734	757	23.7
32	150	150	132	135	4.32	200	927	933	816	841	26.3
33	154	155	136	139	4.45	250	1 159	1 167	1 020	1 051	32.9
34	159	160	140	143	4.57	300	1 391	1 400	1 224	1 241	39.5

 Remark) 1 mm²/s=1 cSt (centi stokes)

Koyo products information

Contents

Bearings and equipment

For automobiles	D 2
For motorcycles	D 4
For metal production equipment	D 4
For railway rolling stock	D 5
For industrial machinery	D 5
For extreme special environment (EXSEV bearing series)	D 6
For space and aircraft	D 7
For office automation equipment and electric home appliances ...	D 7
For other machinery	D 8
High precision machine components and apparatus	D 9
Control type magnetic bearing spindles	D 9
Drive shafts	D10
Propeller shafts	D10
Constant velocity joints	D10
Oil seals, o-rings and resin parts	D10
Factory automation systems and high precision machine tools	D11
Heat technology equipment	D11
Electronic parts	D11

Automobiles



■ Hub units built-in ABS sensor



■ DAC type double-row angular contact ball bearings for wheel



■ DU type double-row tapered roller bearings for wheel



■ Water pump bearings (CAT. NO. 285E)



■ Clutch release bearings (CAT. NO. 283E)



■ Bearing units for tensioner / idler pulleys



■ Cross pin kits for universal joints
(needle roller bearings with dimpled bottom drawn cup)



■ One-way clutches (CAT. NO. 286E)



■ Ceramic ball bearings for turbocharger



■ Pressed rocker arm rollers



■ Steering systems
■ Steering joints



■ Telescopically adjustable electric tilt safety steering column

Motorcycles



■ Bearings for motorcycle transmission



■ Bearings for motorcycle wheel

Metal production equipment



■ Large size bearings for rolling mill roll necks
(CAT. NO. 211E)



■ Sealed type four-row tapered roller bearings
for rolling mill roll necks (CAT. NO. 195E)



■ Backing bearings for sendzimir mills



■ Full complement type cylindrical roller bearings
with self-aligning ring (for guide rolls of continuous
casting facilities) (CAT. NO. 165E)

Railway rolling stock



■ Double-row cylindrical roller bearings for axle journals (CAT. NO. 201E)



■ Sealed type double-row tapered roller bearings (ABU bearing) for axle journals (CAT. NO. 201E)

Industrial machinery (1)



■ Super-large size slewing rim bearings for tunnel borers (CAT. NO. 201E)



■ Full complement type double-row cylindrical roller bearings for crane rope sheaves (CAT. NO. 201E)



■ Plummer blocks (CAT. NO. 201E)



■ Bearings for forklift trucks (CAT. NO. 194E)

Industrial machinery (2)



■ Precision bearings for machine tools
(CAT. NO. 297E)



■ Ceramic bearings for machine tools
(CAT. NO. 297E)



■ Super-thin section ball bearings for robot
(CAT. NO. 201E)



■ Super-thin section tapered roller bearings for
robot reduction gears

Extreme special environment (EXSEV bearing series)



■ Ceramic bearings (CAT. NO. 293E)



■ Liner ball bearings, liner way and cross roller way
(CAT. NO. 293E)

Space and aircraft



■ Bearings for aircraft jet engines



■ Space and aircraft bearings



■ Space and aircraft bearings



■ Space and aircraft bearings



Office automation equipment and electric home appliances



■ Spindle units for magnetic discs



■ Integral type bearings



■ Spindle units for rotary encoders

Other machinery



■ Needle roller bearings (CAT. NO. 201E)

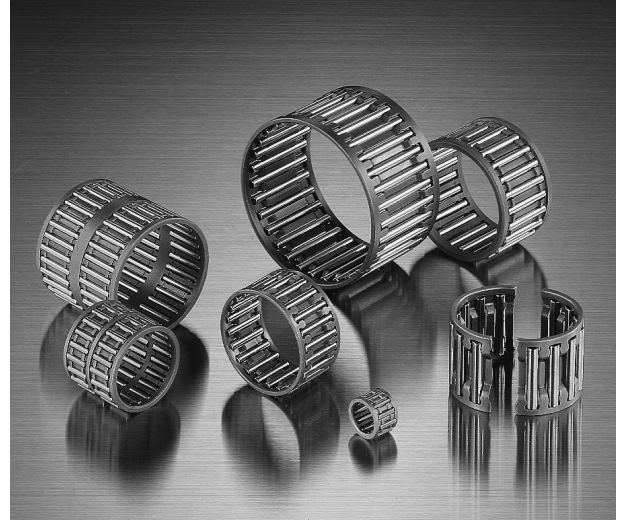

■ Cage and rollers (CAT. NO. 201E)

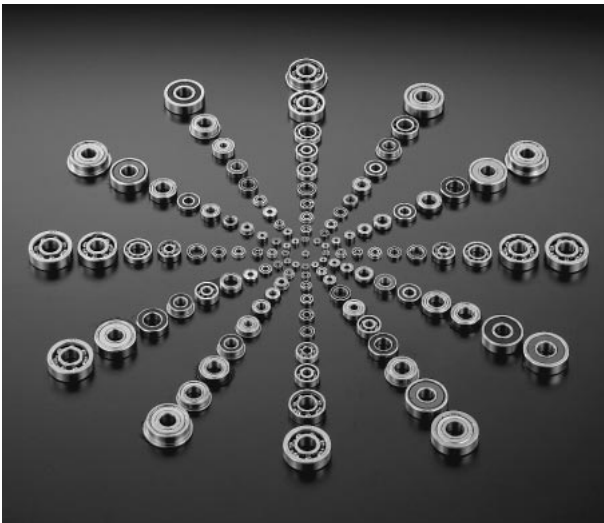

■ Extra-small & miniature ball bearings
(CAT. NO. 295E)



■ Extra-small & miniature ball bearings with pulleys



■ Miniature one-way clutches
and one-way clutch units (CAT. NO. 113E)



■ Track rollers (CAT. NO. 201E)

High precision machine components and apparatus



■ Hydrodynamic grooved bearings



■ Traction drive spindle units
(CAT. NO. 127E)



■ Oil air lubricator and air clean unit
(CAT. NO. 297E)



■ Precision spindle units (CAT. NO. 280)

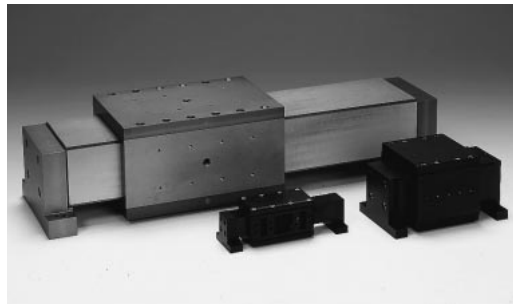

■ Air slide bearings

Control type magnetic bearing spindles



■ Magnetic bearing spindle units
for machine tools



■ Magnetic bearing spindles
for turbo molecular pumps

Drive shafts (CAT. NO. 235E)

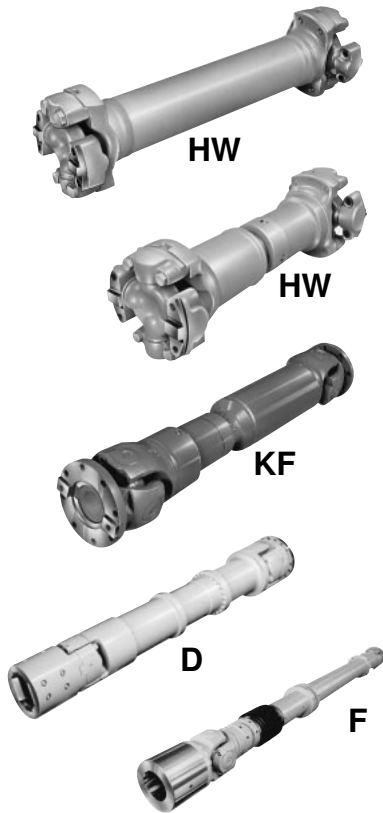

■ Various types of drive shafts



■ Drive shafts with safety cover

Propeller shafts



■ Propeller shafts with ball splines

Constant velocity joints



■ Double cardan constant velocity joints

Oil seals, o-rings and resin parts

KOYO SEALING TECHNO CO., LTD.



■ Oil seals

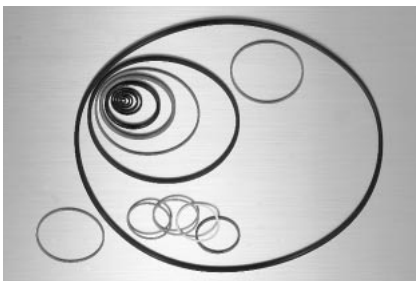

■ O-rings



■ Resin parts

Factory automation systems and high precision machine tools

KOYO MACHINE INDUSTRIES CO., LTD.

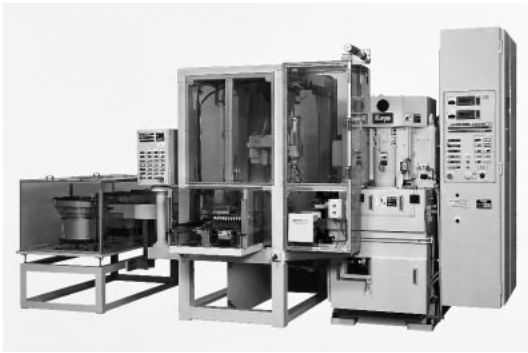

■ Double disk grinder

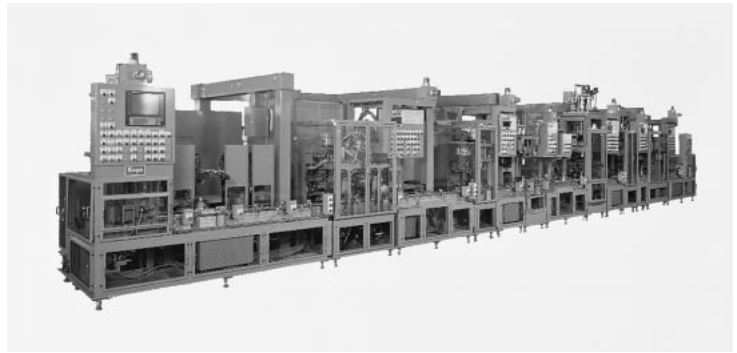

■ Factory automation system



■ Centerless grinder



■ Precision ball screws



■ Spindle units



■ Indexing chuck

Heat technology equipment

KOYO THERMO SYSTEMS CO., LTD.

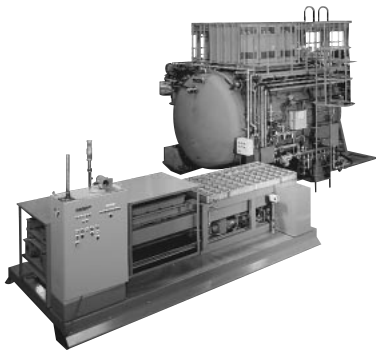

■ Vacuum furnace



■ Clean oven



■ Vertical type diffusion furnace

Electronic parts

KOYO ELECTRONICS INDUSTRIES CO., LTD.



■ Photoelectric sensors



■ Rotary encoders

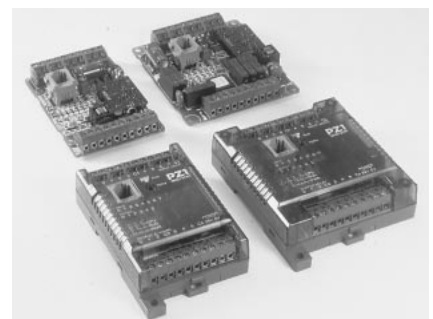

■ Programmable logic controllers

INTERNATIONAL NETWORK

KOYO SEIKO CO., LTD. HEAD OFFICE

No.5-8, Minamisemba 3-chome, Chuo-ku, Osaka 542-8502, JAPAN
TEL : 81-6-6245-6087
FAX : 81-6-6244-0814
TLX : 63040 (KOYO OSJ)

OFFICES

KOYO CANADA INC.

5324 South Service Road, Burlington, Ontario L7L 5H5, CANADA
TEL : 1-905-681-1121
FAX : 1-905-681-1392

* KOYO CORPORATION OF U.S.A.

29570 Clemens Road, P.O.Box 45028 Westlake,
OH 44145, U.S.A.
TEL : 1-440-835-1000
FAX : 1-440-835-9347
TLX : 0985461(AMKOY RKVR)

* KOYO CORPORATION OF U.S.A.

47771 Halyard Drive, Plymouth, MI 48170, U.S.A.
TEL : 1-734-454-1500
FAX : 1-734-454-4076

KOYO STEERING SYSTEMS OF U.S.A. INC.

47771 Halyard Drive, Plymouth, MI 48170, U.S.A.
TEL : 1-734-454-7067
FAX : 1-734-454-7059

KOYO DE MÉXICO, S.A.

Av.Primer de Mayo No.153, 53500 Naucalpan
Edo.de México, MÉXICO
TEL : 52-5-358-0214/0077
FAX : 52-5-576-8827/8871

KOYO LATIN AMERICA, S.A.

P.O.Box 6-1797, El Dorado, Panama, REPUBLICA DE PANAMA
TEL : 507-264-0921/0977
FAX : 507-264-2782/507-269-7578

KOYO ROLAMENTOS DO BRASIL LTDA.

Rua Desembargador Eliseu Ghilherme 304, 7-Andar,
Paraiso CEP 04004-30, BRASIL
TEL : 55-11-3887-9173
FAX : 55-11-3887-3039

THAI KOYO CO., LTD.

193/53 Lake Rajada Office Complex, 14th Floor Unit B,
Rachadapisek Road, Klongtoey, Bangkok 10110, THAILAND
TEL : 66-2-264-0395/661-9603~9605
FAX : 66-2-661-9606

KOYO SINGAPORE BEARING (PTE.) LTD.

38 Tuas West Road, Singapore 638385, SINGAPORE
TEL : 65-274-2200
FAX : 65-862-1623

PHILIPPINE KOYO BEARING CORPORATION

Rm.504, Comfoods Bldg., Cor.Gil Puyat Ave. and
Pasong Tamo, Makati City, PHILIPPINES
TEL : 63-2-817-8881/8901
FAX : 63-2-867-3148

KOYO SEIKO CO., LTD. SEOUL BRANCH

Inwoo Building 6F, 539-11, Shinsa-Dong,
Kangnam-Ku, Seoul, KOREA
TEL : 82-2-549-7922
FAX : 82-2-549-7923

KOYO SEIKO CO., LTD. BEIJING LIAISON OFFICE

Room 809, Jingtai Tower, 24 Jianguomenwai Street, Beijing,
China, 100022
TEL : 86-10-6515-0037
FAX : 86-10-6515-0522

KOYO SEIKO CO.,LTD. SHANGHAI LIAISON OFFICE

Rm.402, Aetna Tower, 107 Zunyi Road, Shanghai 200051, CHINA
TEL : 86-21-6237-5280
FAX : 86-21-6237-5277

*** KOYO AUSTRALIA PTY. LTD.

P.O.Box 442, Rydalmere, 2116 N.S.W., AUSTRALIA
TEL : 61-2-9638-2355
FAX : 61-2-9638-3368

KOYO SEIKO CO., LTD. EUROPEAN CENTRAL OFFICE

Markerkant 13-01, 1314 AL Almere, THE NETHERLANDS
TEL : 31-36-5383333
FAX : 31-36-5347212

*** KOYO KULLAGER SCANDINAVIA A.B.

Kanalvagen 1B, 194 61 Upplands-Vasby, SWEDEN
TEL : 46-8-594-212-00
FAX : 46-8-594-212-29

KOYO STEERING EUROPE S.A.S.

Zone Industrielle du Broteau, B.P.1, 69540 Irigny, FRANCE
TEL : 33-472-39-4444
FAX : 33-472-39-2188

* KOYO (U.K.) LTD.

Whitehall Avenue, Kingston, Milton Keynes MK10 OAX,
UNITED KINGDOM
TEL : 44-1908-289300
FAX : 44-1908-289333

*** EUROPA-KOYO B.V.

P.O.Box 1-2965 ZG, Nieuwpoort, THE NETHERLANDS
TEL : 31-184-606800
FAX : 31-184-602572/606857

KOYO ROMANIA REPRESENTATIVE OFFICE

Str. Frederic Jolliot-Curie, Nr.3, Etaj 1, Ap.2, Sector 5
Bucharest, RUMANIA
TEL : 40-1-410-4170/4182/0984
FAX : 40-1-410-1178

* KOYO DEUTSCHLAND GMBH.

P.O.Box 73 06 60, D-22126 Hamburg, GERMANY
TEL : 49-40-67-9090-0
FAX : 49-40-67-9203-0
TLX : 213138(KOYO D)

KOYO FRANCE S.A.

8 Rue Guy Moquet, B.P.189 Z.I., 95105 Argenteuil Cedex, FRANCE
TEL : 33-1-3998-4222
FAX : 33-1-3998-4244/4249

KOYO IBERICA, S.A.

Calle Belfast 15 Naves A y B, Poligono Ind. "Las Mercedes",
28022 Madrid, SPAIN
TEL : 34-91-329-0818
FAX : 34-91-747-1194

KOYO ITALIA S.R.L.

Via Bronzino 9, 20133 Milano, ITALY
TEL : 39-02-2951-0844
FAX : 39-02-2951-0954

BEARING PLANTS

* KOYO CORPORATION OF U.S.A. (MANUFACTURING DIVISION)

– Orangeburg Plant –
P.O. Drawer 967, Highway 601 North, Orangeburg, SC 29115, U.S.A.
TEL : 1-803-536-6200
FAX : 1-803-534-0599
– Richland Plant –
1006 Northpoint Blvd. Blythewood, SC 29016, U.S.A.
TEL : 1-803-691-4624/4633
FAX : 1-803-691-4655

* KOYO MANUFACTURING (THAILAND) CO.,LTD.
172 Moo 12, Tambol Bangwua, Amphur Bangpakong,
Chachoengsao 24130, THAILAND
TEL : 66-38-531-988/993
FAX : 66-38-531-996

KOYO MANUFACTURING (PHILIPPINES) CORPORATION
Lima Technology Center, Municipality of Malvar, Batangas
Province, 4233 PHILIPPINES
TEL : 63-43-981-0088
FAX : 63-43-981-0001

* KOYO BEARINGS (EUROPE) LTD.
P.O. Box 101, Elmhirst Lane, Dodworth, Barnsley,
South Yorkshire, S75 3TA, UNITED KINGDOM
TEL : 44-1226-733200
FAX : 44-1226-204029

*** KOYO DALIAN PRECISION BEARINGS CO., LTD.
No.30 Industrial District Daikei, Dalian Economic & Technical
Development Zone, Dalian, CHINA
TEL : 86-411-731-0972/0974
FAX : 86-411-731-0973

*** WUXI KOYO BEARING CO., LTD.
3-6 Li Yuan Economic Development District, Wuxi, Jiangsu, CHINA
TEL : 86-510-516-1901
FAX : 86-510-516-1143

* DALIAN KOYO WAZHOU AUTOMOBILE BEARING CO., LTD.
No.1 Gongji North Street, Wafangdian City, Liaoning Province, CHINA
TEL : 86-411-5508114
FAX : 86-411-5508049

** KOYO ROMANIA S.A.
1, Tr. Magurele Street, 0700 Alexandria, RUMANIA
TEL : 40-4-731-2605
FAX : 40-4-731-5892

STEERING SYSTEM PLANTS

KOYO STEERING SYSTEMS OF U.S.A. INC. VIRGINIA PLANT
111 Franklin Plaza, Suite 333, Roanoke, Virginia 24001, U.S.A.
TEL : 1-540-343-1550
FAX : 1-540-344-6096

TRW KOYO STEERING SYSTEMS COMPANY
55 Excellence Way, Vonore, Tennessee 37885, U.S.A.
TEL : 1-423-884-9200
FAX : 1-423-884-9295

KOYO STEERING BRASIL LTDA.
Rua Sete de Setembro, 4698 Cj. 101/102-Batel-Curitiba,
PR-Brasil-CEP 80240-000
TEL : 55-41-242-5914
FAX : 55-41-673-2659

*** KOYO STEERING ARGENTINA S.A.
Perdriel 1859 1279-Buenos Aires, ARGENTINA
TEL : 54-11-4302-7696
FAX : 54-11-4302-7836

*** T&K AUTOPARTS SDN. BHD.
P.O.BOX 7300, 40710 Shah Alam, Lot 24 Jaldn Delima (1/3),
Subang Hi-Tech Industrial Park, Batu Tiga 40000 Shah Alam,
Selangor Darul Ehsan, MALAYSIA
TEL : 60-3-56351178
FAX : 60-3-56352379

* SOCIETE DE MECANIQUE D'IRIGNY S.A.
Zone Industrielle du Broteau B.P. 1, 69540 Irigny, FRANCE
TEL : 33-472-39-44-44
FAX : 33-478-51-21-88

* HYDROPERFECT INTERNATIONAL S.A.
Z.I.-26, Rue Condorcet B.P. 87, 94432 Chennevieres-
Sur-Marne Cedex, FRANCE
TEL : 33-1-4962-2800
FAX : 33-1-4576-6840

* KOYO STEERING (THAILAND) CO., LTD.
172 Moo 12 Tambol Bangwua, Amphur Bangpakong,
Chachoengsao 24130, THAILAND
TEL : 66-38-830-571~578
FAX : 66-38-830-579

*** YUBEI KOYO STEERING SYSTEM CO., LTD.
No.322 Heping Road, Xinxiang City, Henan Province 453003, CHINA
TEL : 86-373-5023740
FAX : 86-373-5023741

*** FAW-KOYO STEERING SYSTEMS CO.,LTD.
No.122 Dongfeng Street, Changchun City, CHINA
TEL : 86-431-597-6274
FAX : 86-431-597-7404

TECHNICAL CENTERS

** KOYO CORPORATION OF U.S.A.
TECHNICAL CENTER
47771 Halyard Drive, Plymouth, MI 48170, U.S.A.
TEL : 1-734-454-1500
FAX : 1-734-454-4076

KOYO SEIKO CO., LTD.
EUROPEAN TECHNICAL CENTRE
Markerkant 13-02, 1314 AL Almere, THE NETHERLANDS
TEL : 31-36-5383350
FAX : 31-36-5302656

KOYO STEERING SYSTEMS OF U.S.A. INC.
TECHNICAL CENTER
47771 Halyard Drive, Plymouth, MI 48170, U.S.A.
TEL : 1-734-454-7067
FAX : 1-734-454-7059

KOYO STEERING EUROPE S.A.S.
EUROPEAN TECHNICAL CENTER
Zone Industrielle du Broteau, B.P.1, 69540 Irigny, FRANCE
TEL : 33-472-39-4444
FAX : 33-478-51-2188

BALL & ROLLER BEARINGS

POPULAR SIZE

VALUE & TECHNOLOGY



CAT.NO.203E-1

Printed in Japan '00.4-2CNK ('97.3)